

RADIO TEST EQUIPMENT MANUAL

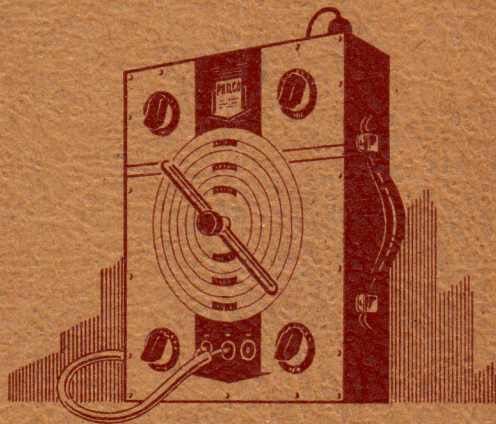

**OPERATING AND SERVICE INSTRUCTIONS
SCHEMATIC WIRING DIAGRAMS**

Scanned and Prepared
by Dale H. Cook

Prepared by PHILCO for
PHILCO CORPORATION
PHILADELPHIA, PA., U. S. A.

P H I L C O

PHILCO

**RADIO
TEST EQUIPMENT
MANUAL**



Scanned and Prepared
by Dale H. Cook

Prepared by PHILCO, for
PHILCO CORPORATION
Philadelphia, Pa.
U. S. A.

TABLE OF CONTENTS

	PAGE
Philco Model 020 Volt-Ohmmeter	1
Philco Model 023 Volt-Ohm-Milliammeter	3
Philco Model 025A Volt-Ohm-Milliammeter	4
Philco Model 026 Volt-Ohm-Milliammeter	7
Philco Model 027 Vacuum-Tube Voltmeter	10
Philco Model 028 Vacuum-Tube Voltmeter	11
Philco Model 030 Dynamic Tester	15

PHILCO SIGNAL GENERATORS

Philco Model 016	20
Philco Model 024	23
Philco Model 048A	24
Philco Model 070	25
Philco Model 077	29
Philco Model 088	32
Philco Model 091	33
Philco Model 177	34

PHILCO AUDIO SIGNAL GENERATORS

Philco Model 044	36
Philco Model 055	39

PHILCO TUBE TESTERS

Philco Model 033	42
Philco Model 050	43
Philco Model 066	44
Philco Model 010 Condenser Tester	46
Philco Model 013 Vibrator Tester	47
Philco Model 014 Wireless Station Setter	48
Philco Model 015 Battery Tester	49
Philco Model 022 Cathode-Ray Oscilloscope	50
Philco Model 029 Appliance Tester	54

Introduction

This book contains technical information on Philco radio test equipment sold up to the time of publication, July 1944.

Its primary purpose is to help Philco distributors, dealers and servicemen keep the thousands of Philco test instruments in good operating condition now when war requirements prevent the building of any new test equipment. After the war is over, Philco will have a new and finer line of equipment designed to meet every requirement of modern service needs.

PHILCO CIRCUIT TESTERS

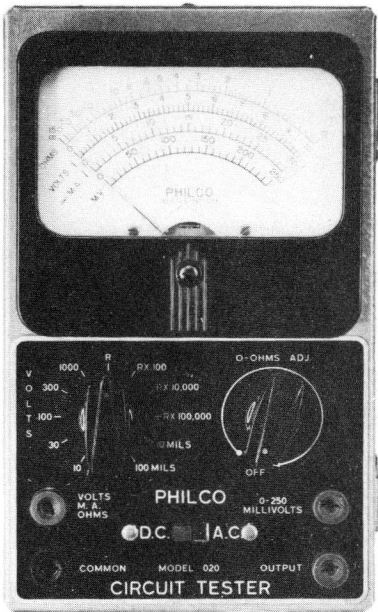

**MODEL 020
VOLT-OHMMETER**

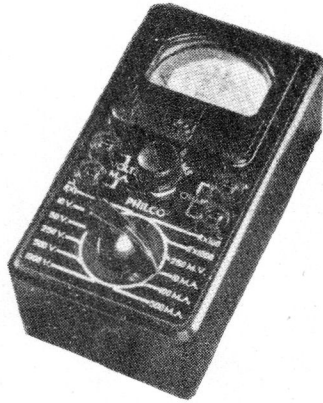

**MODEL 023
VOLT-OHM-MILLIAMMETER**

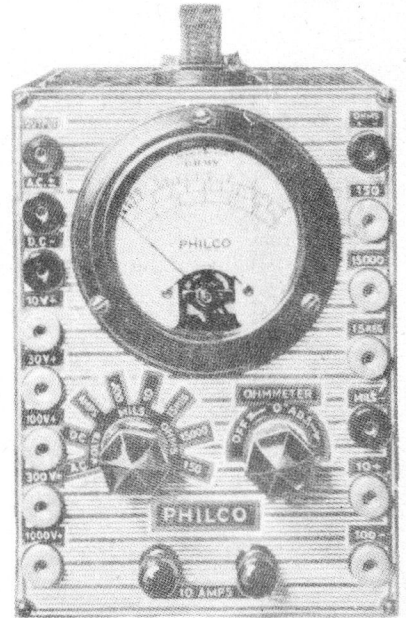

**MODEL 025A
VOLT-OHM-MILLIAMMETER**

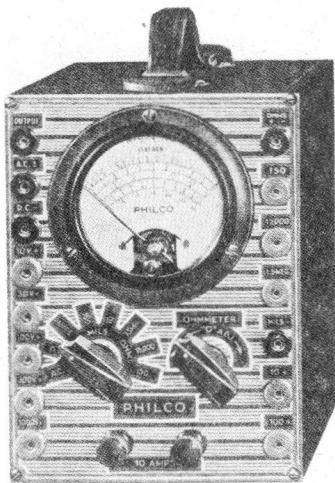

**MODEL 026
VOLT-OHM-MILLIAMMETER**



**MODEL 027
VACUUM TUBE VOLTMETER**

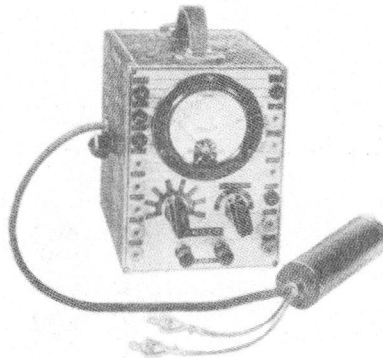

**MODEL 028
VACUUM TUBE VOLTMETER**



**MODEL 030
DYNAMIC TESTER**

PHILCO SIGNAL GENERATORS

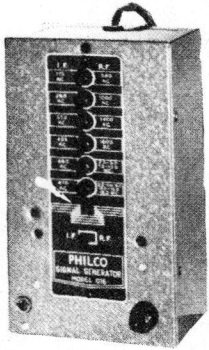

MODEL 016

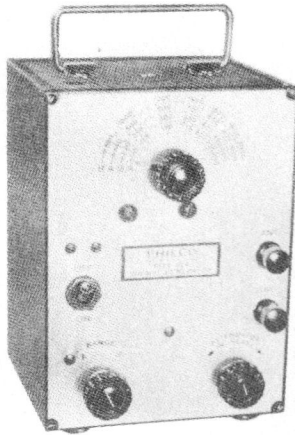

MODEL 024



MODEL 048A

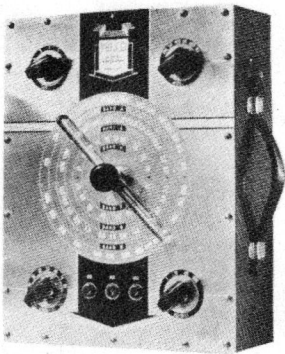

MODEL 070



MODEL 077

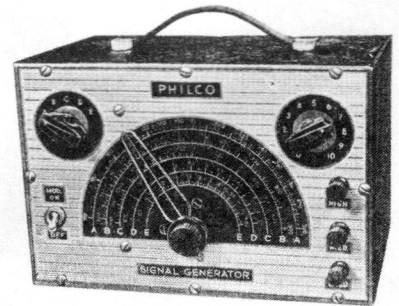

MODEL 088

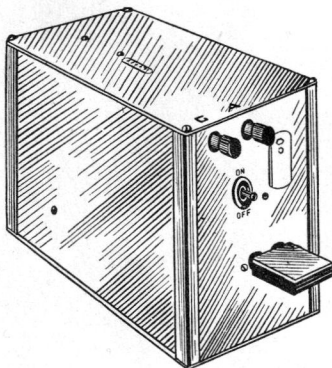

MODEL 091

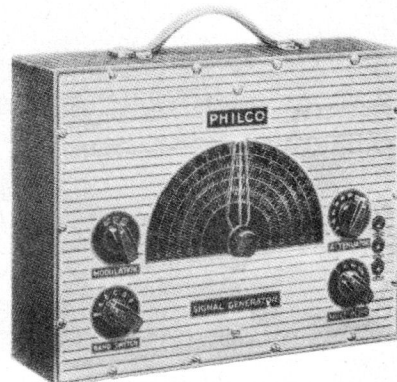

MODEL 177

**PHILCO
AUDIO SIGNAL GENERATORS**



MODEL 044

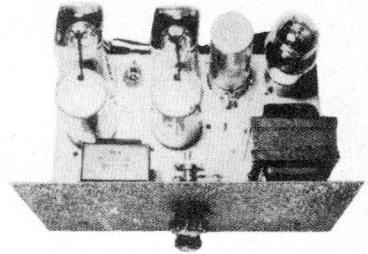

MODEL 055

**PHILCO
TUBE TESTERS**



MODEL 033

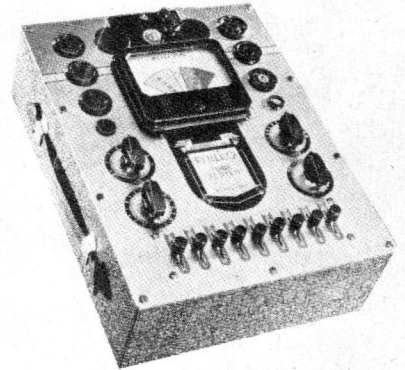

MODEL 050

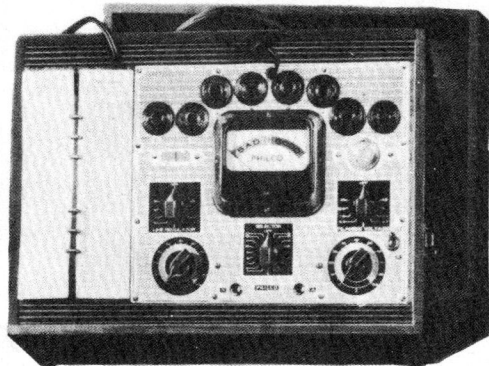

MODEL 066

PHILCO
MISCELLANEOUS TESTING EQUIPMENT

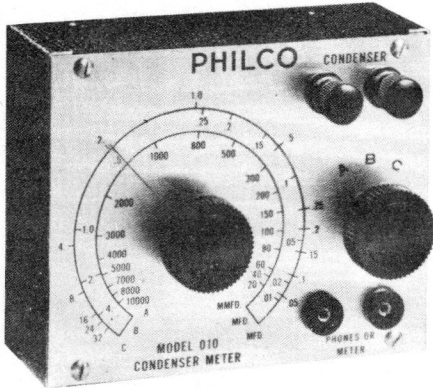

MODEL 010
CONDENSER TESTER

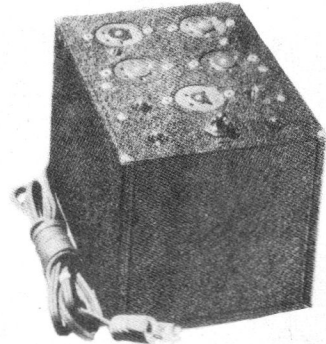

MODEL 013
VIBRATOR TESTER

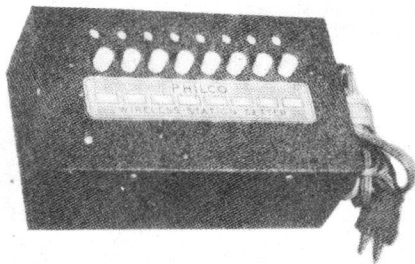

MODEL 014
WIRELESS STATION SETTER

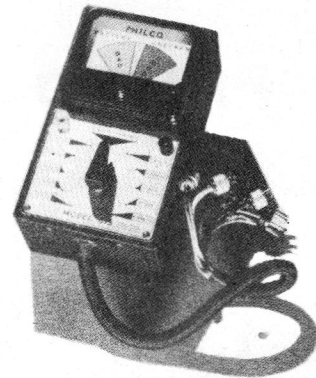

MODEL 015
BATTERY TESTER



MODEL 022
CATHODE-RAY OSCILLOSCOPE

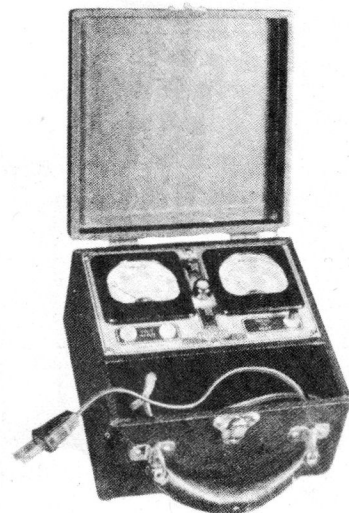

MODEL 029
APPLIANCE TESTER

Section I

PHILCO CIRCUIT TESTERS

Philco Model 020 Volt-Ohmmeter

Philco Model 023 Volt-Ohm-Milliammeter

Philco Model 025A Volt-Ohm-Milliammeter

Philco Model 026 Volt-Ohm-Milliammeter

Philco Model 027 Vacuum-Tube Voltmeter

Philco Model 028 Vacuum-Tube Voltmeter

Philco Model 030 Dynamic Tester

PHILCO CIRCUIT TESTERS

PHILCO MODEL 020 VOLT-OHMMETER

RANGES:

A-C volts: }
D-C volts: } 0—10, 30, 100, 300, 1000.
Output volts: }
Ohms: 0—150, 15,000, 1.5 megohms, 15 megohms.
Current (D.C.):
0—10, 100 milliamperes, 0—200 microamperes.
Millivolts (D.C.): 0—250.

CONTROLS:

All functions and ranges are controlled by a single rotary selector switch. Since this instrument has the unique feature of measuring A.C. and D.C. on the same scales, a two-position switch is provided for changing from A-C to D-C readings. A third control is used for adjusting the zero setting of the ohmmeter. This control also contains the switch that turns on the rectifier tubes.

BATTERY AND TUBE REPLACEMENTS:

A 1.5-volt Philco "D" cell is used in the instrument to operate the two lower resistance ranges (150 and 15,000 ohms). When it is no longer possible to obtain a zero reading on these scales with the test leads shorted, this cell should be replaced. The rectifier system uses two Philco tubes, a type XXD and a type 7C6. If there is any occasion to replace the type XXD tube it may be necessary to make a slight readjustment of the rheostat which is accessible through a hole in the same side of the case as the power cord. This adjustment affects the A-C voltage scales only, and can be reset when measuring a known source of A-C voltage.

LINE CORD CONNECTION:

This cord supplies power to the rectifier tubes for the A-C ranges and the two higher resistance ranges (1.5 and 15 megohms). It should be connected to a 110-volt outlet (either A.C. or D.C.) but when connected to a D-C outlet the plug should be inserted with the proper polarity so that the A-C and higher resistance ranges function normally. If the cord is to be left connected to an outlet at all times, as when the instrument is used in the shop, the switch on the "0 Ohms Adj" Control should be turned off whenever the instrument is not in use. The line cord connection is not required for D-C voltage or current readings, nor for the two lower resistance scales (150 and 15,000 ohms).

D-C VOLTAGE MEASUREMENTS:

Insert the test leads in the pin jacks marked "Common" and "Volts, MA, Ohms." Turn the selector switch to the scale desired.

D-C MILLIAMPERES:

With the test leads connected as above, turn the selector switch to the milliampere scale desired.

D-C MILLIVOLTS:

Insert the test leads in the pin jacks marked "Common" and "Millivolts." When using the millivolt scale the selector switch can be in any voltage position.

D-C MICROAMPERES:

Connect as for D-C Millivolts. Use second scale from the top and multiply readings by 20.

A-C VOLTS:

Insert the test leads in the pin jacks marked "Common" and "Volts, MA, Ohms." Turn the switch on the "0 Ohms Adj." control to the "ON" position and allow time for the rectifier tubes in the instrument to become heated before making A-C voltage measurements. Turn the selector switch to the scale desired.

OUTPUT VOLTS:

Insert the test leads in the pin jacks marked "Common" and "Output", and proceed as in measuring A-C volts.

RESISTANCE MEASUREMENTS:

Insert the test leads in the pin jacks marked "Common" and "Volts, MA, Ohms." Turn the selector switch to the resistance scale desired. Short the test prods together and adjust the "0 Ohms Adj." control for zero indication on the meter. The line cord should be plugged into the electrical outlet when using the two higher resistance scales (1.5 and 15 megohms).

CAUTION

Before using the R x 10,000 and R x 100,000 ranges, make sure that the apparatus under test is not grounded or connected to a power line.

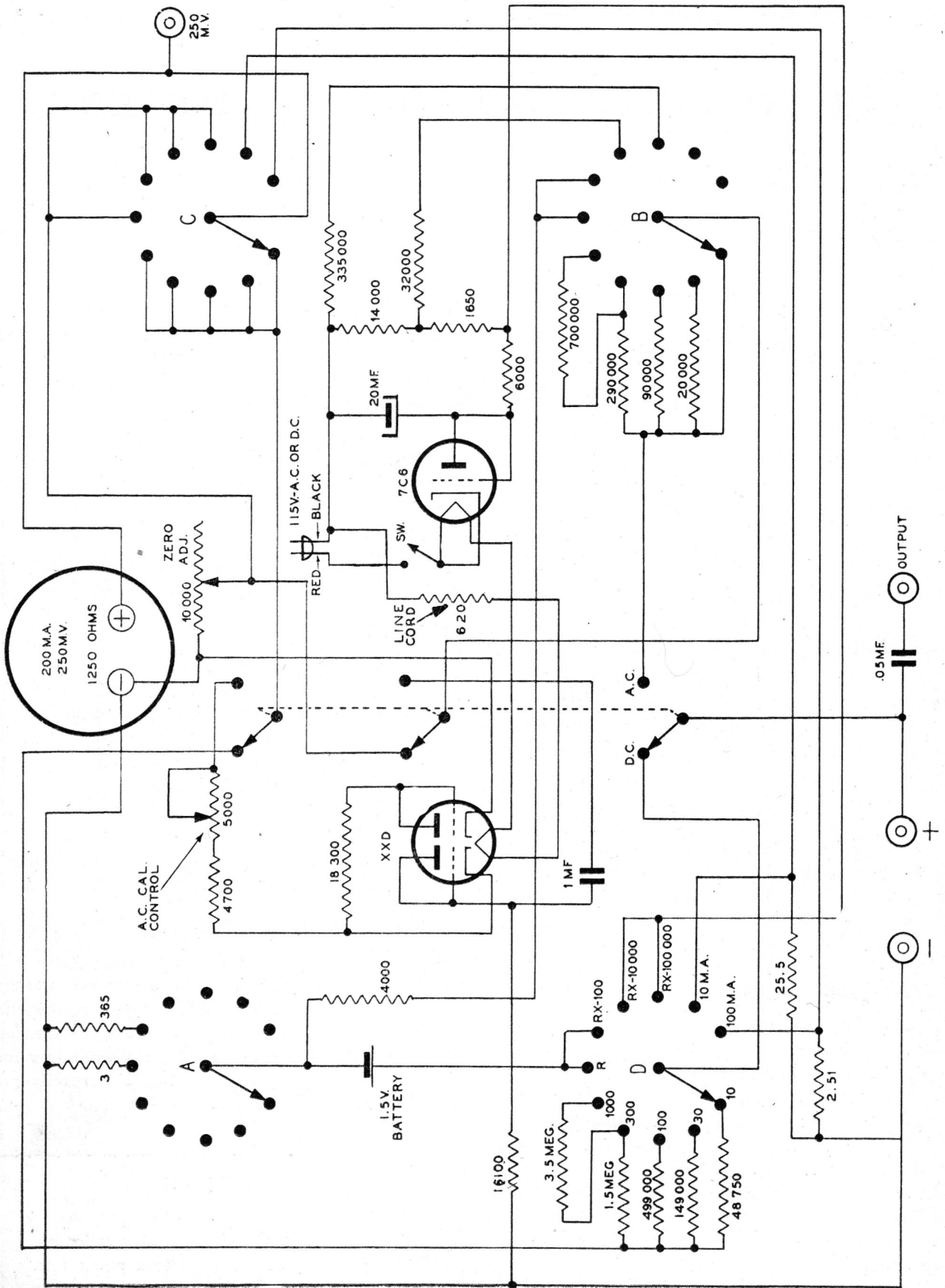

PHILCO MODEL 020 VOLT-OHMMEER (SCHEMATIC DIAGRAM)

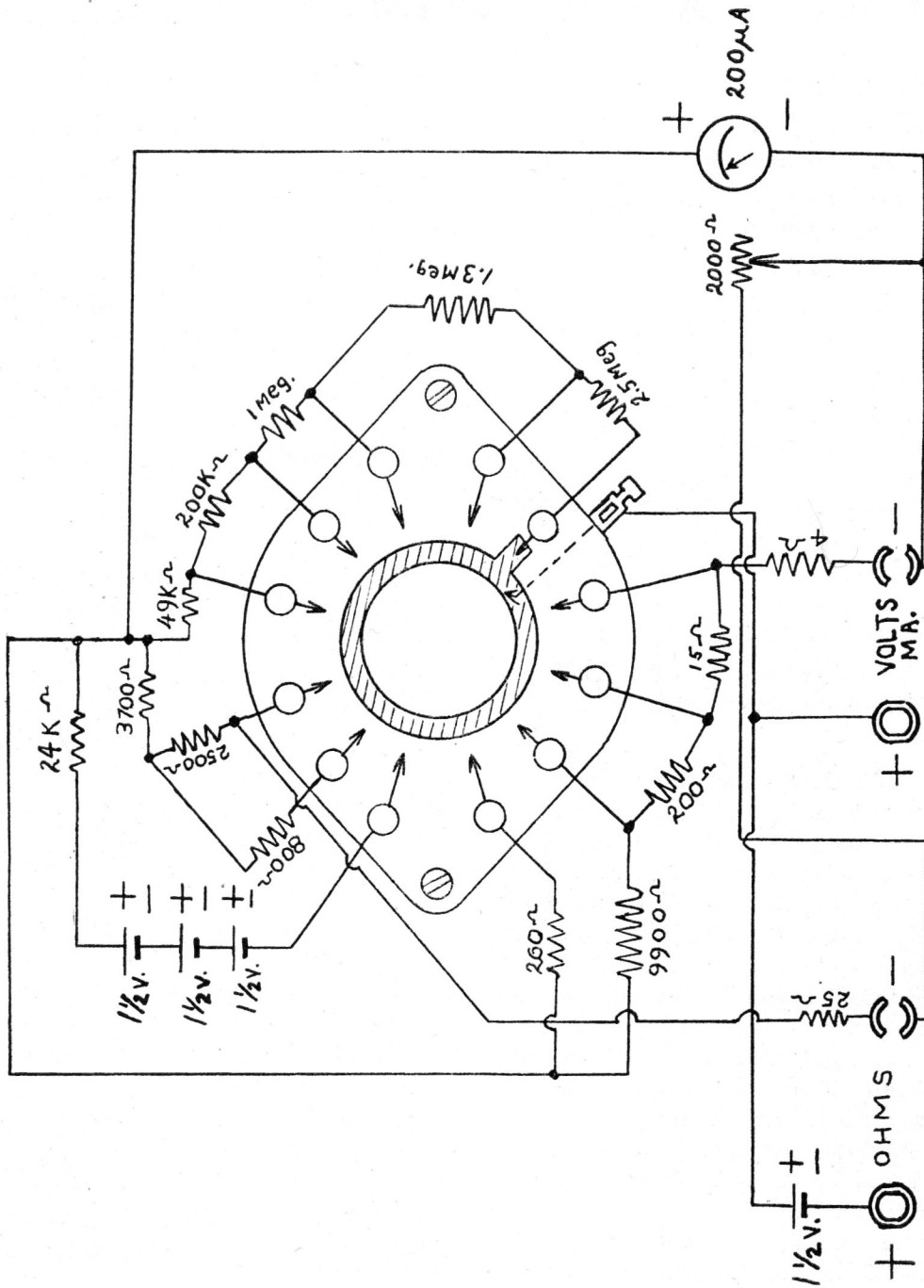

PHILCO MODEL 023 VOLT-OHM-MILLIAMMETER (SCHEMATIC DIAGRAM)

PHILCO CIRCUIT TESTERS

PHILCO MODEL 025-A VOLT-OHM-MILLIAMMETER

OUTPUT METER
D-C VOLTMETER
A-C VOLTMETER
MILLIAMMETER
OHMMETER
CAPACITY METER

★ ★ ★ ★

Philco Model 025-A is a complete unit for testing circuits, checking A-C or D-C voltages, amperes or milliamperes, and also measuring resistances—ohms or megohms. It can also be used to measure capacity. When used in connection with a suitable signal generator, it enables all necessary tests to be made on a receiver. The various tests with the Model 025-A are made as follows:

OUTPUT METER

Be sure the ohmmeter knob is in the "Off" position. Turn the selector knob to the "A.C." position.

To use the meter for checking output (such as when adjusting compensating condensers in a set with the aid of a signal generator), the two special adapter leads provided are used. Insert the "phone tip" end of one of these leads into the "output" jack and the other into one of the lower voltage "positive (+) volts" jacks, depending on the strength of the signal to be measured. The other ends of the leads are to be slipped over the output prongs of the output tube or tubes in the set under test. If the set uses a single output tube, connect to the plate and cathode (plate and filament in tubes having no cathode); in push-pull sets slip one adapter over the plate of each output tube. The comparative output of the set at different adjustments is indicated by the comparative amount of deflection of the meter needle.

Output jack is for use only in measuring output of receiver. When measuring A-C voltages, use A-C jack, as described below under "A-C Voltmeter."

D-C VOLTMETER

Be sure the ohmmeter knob is in the "Off" position. Turn the selector knob to the "D.C." position.

To use the meter to measure D-C voltages, employ the two leads having phone tips at one end and test prods on the other. Insert the tip at the opposite end of the lead carrying the black prod into the jack marked D.C. (—) and the tip on the lead carrying the red prod into one of the jacks marked D.C. (+), depending on the voltage range needed. For example, if you wish to measure a voltage which will be between 30 and 100, insert the tip into the jack marked 100V+. The voltage measured will be indicated on the upper D-C scale. When using the 300V+ jack, multiply the reading on the 30-volt scale by 10; when using the 1000V+ jack, multiply the reading on the 10-volt scale by 100.

A-C VOLTMETER

Be sure the ohmmeter knob is in the "Off" position. Turn the selector knob to the "A.C." position.

Insert the phone tip of the lead carrying the black prod into the jack marked A.C.±, and the one carrying the red prod into one of the "positive volts" jacks, depending on the voltage to be measured. Read voltages on the scales marked "A.C.", the same as explained above under D-C Voltmeter.

Do NOT use "OUTPUT" jack to measure A-C voltages.

D-C MILLIAMMETER

Be sure the ohmmeter knob is at "Off". Turn the selector knob to the "10 mils" or "100 mils" position (depending on current to be measured).

Insert the phone tip on the black prod lead into the "MILS—" jack and the red prod lead into the 10+ or 100+ jack, corresponding to the position of the selector switch. Read milliamperes on the 0-10 D-C volt scale. Multiply reading by 10 if using the 100 mil jack.

OHMMETER

NOTE—While using the ohmmeter, the "0 Adj." is turned "On" and adjusted for the scale being used. *At all other times the control must be in the "Off" position to insure correct readings.*

PHILCO CIRCUIT TESTERS

Resistance is measured on the top scale on the meter. Three ohmmeter ranges are available—0-150 ohms, 0-15000 ohms and 0-1.5 megohms. Set the selector switch at the proper one of the three positions, depending upon the approximate value of the circuit or unit to be measured, and insert the leads carrying the test prods, black into the top right-hand jack (Ohms + —) and red into one of the three below it, corresponding to the position of the selector switch.

Touch the metal tip of the test prods together, turn the ohmmeter knob "ON" and to the right until the meter reads "zero." You can then measure the resistance desired by touching the test prods to the terminals of the circuit or unit. If using the 15,000-ohm connections, add two zeros to the meter reading; if the 1.5 meg. connections, add four zeros to the meter reading.

The 025-A ohmmeter has a series arrangement throughout the three resistance scales, and no current is drawn at any time except when resistance tests are actually being made. The circuit is so arranged that leaving the "0 adjuster" in the "On" position does not cause any current drain from the batteries. However, it must be left in the "Off" position when voltage and current scales are being used, otherwise the meter readings will be incorrect.

A single $1\frac{1}{2}$ -volt flashlight cell is used on the 0-150 ohm scale. This battery should be checked occasionally to make sure that it is in good condition.

CAPACITY METER

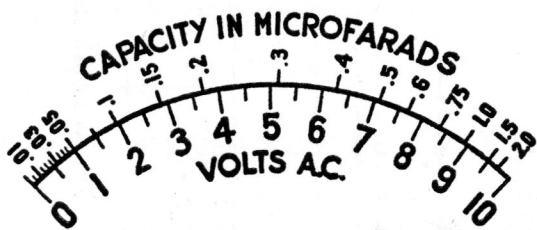

CALIBRATION CHART FOR CAPACITY

To measure capacity it will be necessary to use a Philco potentiometer and a cartridge-type resistor, value shown in diagram herewith.

Make the connections as shown in the diagram, using the 0-100 volt A-C scale of the meter and adjusting potentiometer for 100 volts with the test prods (leading to condenser to be tested) in short circuit. Use calibration chart for capacity.

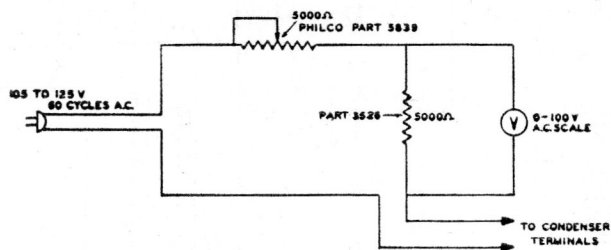

EXTERNAL CIRCUIT FOR CAPACITY METER

REPLACING BATTERY

Model 025-A contains two Philco type P-155, 22 $\frac{1}{2}$ -volt dry battery units secured to (inside) the case by clamps. The batteries should be replaced when their voltage drops below 17 volts (indicated by inability to obtain a "zero adjustment" on the meter). To replace the batteries, remove the brass head bolts which hold the clamps (after removing front panel of instrument), disconnect the batteries and lift them from case.

To replace the $1\frac{1}{2}$ -volt cell simply remove the plate and spring on the back of the 025-A case. The battery then slips in very easily.

Connect the + terminal of the top battery to the -22 $\frac{1}{2}$ terminal of the bottom battery. Connect the green lead to the -22 $\frac{1}{2}$ terminal of the top battery, the white lead to the + terminal of the bottom battery, and the red to the -3 terminal of the bottom battery.

PHILCO CIRCUIT TESTERS

PHILCO MODEL 026 VOLT-OHM-MILLIAMMETER

OUTPUT METER
D-C VOLTMETER
A-C VOLTMETER
MILLIAMMETER
OHMMETER
CAPACITY METER

★ ★ ★ ★

INSTALLING BATTERIES

The Circuit Tester requires two 22½-volt "C" batteries, secured inside the case by means of clamps which fit across top and sides of batteries. In addition, a "No. 2" 1½-volt cell is required, for which a separate compartment is provided at back of case. The battery connections are shown in diagram below.

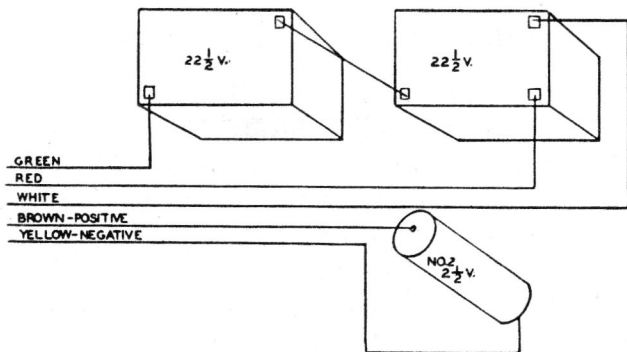

WIRING OF BATTERIES

Philco Model 026 is a complete unit for testing circuits, checking A-C or D-C voltages, D-C amperes or milliamperes, and also measuring resistance. It can also be used to measure capacity. When used in connection with a suitable signal generator, such as Philco Model 077, it enables all usual tests to be made on a receiver. The various tests with the Model 026 are made as follows:

OUTPUT METER

Be sure the ohmmeter knob is in the "Off" position. Turn the selector knob to the "A.C." position.

To use the meter for checking output (such as when adjusting compensating condensers in a set with the aid of a signal generator), the two special adapter leads pro-

vided are used. Insert the "phone tip" end of one of these leads into the "output" jack and the other into one of the lower voltage "positive (+) volts" jacks, depending on the strength of the signal to be measured. The other ends of the leads are to be slipped over the output prongs of the output tube or tubes in the set under test. If the set uses a single output tube, connect to the plate and cathode (plate and filament in tubes having no cathode); in push-pull sets slip one adapter over the plate of each output tube. The comparative output of the set at different adjustments is indicated by the comparative amount of deflection of the meter needle.

Output jack is for use only in measuring output of receiver. When measuring A-C voltages, use A-C jack, as described below under "A-C Voltmeter."

D-C VOLTMETER

Be sure the ohmmeter knob is in the "Off" position. Turn the selector knob to the "D.C." position.

To use the meter to measure D-C voltages, employ the two leads having phone tips at one end and test prods on the other. Insert the tip at the opposite end of the lead carrying the black prod into the jack marked D.C. (-) and the tip on the lead carrying the red prod into one of the jacks marked D.C. (+), depending on the voltage range needed. For example, if you wish to measure a voltage which will be between 30 and 100, insert the tip into the jack marked 100V+. The voltage measured will be indicated on the upper D-C scale. When using the 300V+ jack, multiply the reading on the 30-volt scale by 10; when using the 1000V+ jack, multiply the reading on the 10-volt scale by 100.

A-C VOLTMETER

Be sure the ohmmeter knob is in the "Off" position. Turn the selector knob to the "A.C." position.

Insert the phone tip of the lead carrying the black prod into the jack marked A.C.±, and the one carrying the red prod into one of the "positive volts" jacks, depending on the voltage to be measured. Read voltages on the scales marked "A.C.", the same as explained above under "D-C Voltmeter."

Do NOT use "OUTPUT" jack to measure A-C voltages.

PHILCO CIRCUIT TESTERS

D-C MILLIAMMETER

Be sure the ohmmeter knob is at "Off". Turn the selector knob to the "10 mils" or "100 mils" position (depending on current to be measured).

Insert the phone tip on the black prod lead into the "MILS—" jack and the red prod lead into the 10+ or 100+ jack, corresponding to the position of the selector switch. Read milliamperes on the 0-10 D-C volt scale. Multiply reading by 10 if using the 100 mil jack.

OHMMETER

NOTE—While using the ohmmeter, the "0 Adj." is turned "On" and adjusted for the scale being used. *At all other times the control must be in the "Off" position to insure correct readings.*

Resistance is measured on the top scale on the meter. Three ohmmeter ranges are available—0-150 ohms, 0-15000 ohms and 0-1.5 megohms. Set the selector switch at the proper one of the three positions, depending upon the approximate value of the circuit or unit to be measured, and insert the leads carrying the test prods, black into the top right-hand jack (Ohms + —) and red into one of the three below it, corresponding to the position of the selector switch.

Turn the ohmmeter knob "ON". Then rotate the knob about $\frac{1}{4}$ turn. Now touch the metal tips of the test prods together and adjust the ohmmeter knob until the meter reads "ZERO". You can then measure the resistance desired by touching the test prods to the terminals of the circuit or unit. If using the 15,000-ohm connections, add two zeros to the meter reading; if the 1.5 meg. connections, add four zeros to the meter reading.

The 026 ohmmeter has a series arrangement throughout the three resistance scales, and *no current is drawn at any time except when resistance tests are actually being made.* The circuit is so arranged that leaving the "0 adjuster" in the "On" position does not cause any current drain from the batteries. However, it must be left in the "Off" position when voltage and current scales are being used, otherwise the meter readings will be incorrect.

CAPACITY METER

To measure capacity it will be necessary to use a Philco potentiometer and a cartridge-type resistor, value shown in diagram herewith.

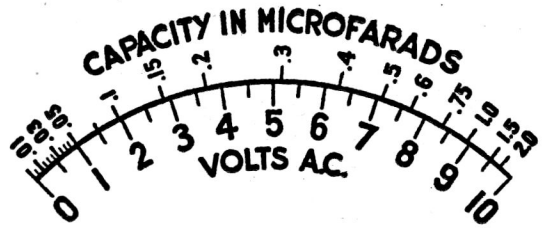

CALIBRATION CHART FOR CAPACITY

Make the connections as shown in the diagram, using the 0-100 volt A-C scale of the meter and adjusting potentiometer for 100 volts with the test prods (leading to condenser to be tested) in short circuit. Use calibration chart for capacity test.

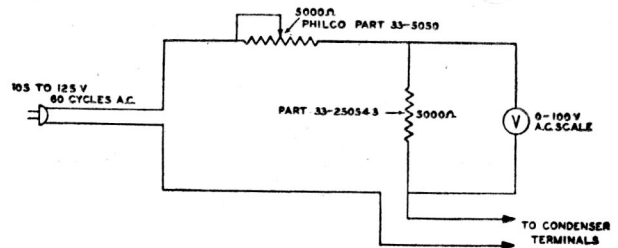

EXTERNAL CIRCUIT FOR CAPACITY METER

REPLACING BATTERIES

Model 026 requires two $22\frac{1}{2}$ -volt dry battery units, size 4" x 3" x $2\frac{1}{2}$ ", with a 3-volt tap and one $1\frac{1}{2}$ -volt flashlight cell, size No. 2, for operation of the ohmmeter circuit. This battery should be checked occasionally to make sure that it is in good condition.

To install the batteries, take off the front instrument panel from the case by removing the screws around the outer edge of panel. The $22\frac{1}{2}$ -volt batteries are then secured to the inside top and bottom of the case by clamps which are held in place by bolts and nuts. Four holes are provided in the case; two in the back, one in the top and one in the bottom, for attaching these clamps.

The batteries should be replaced when their voltage drops below 17 volts (indicated by inability to obtain a "zero adjustment").

Connect the + terminal of the top battery to the $-22\frac{1}{2}$ terminal of the bottom battery. Connect the green lead to the $-22\frac{1}{2}$ terminal of the top battery, the white lead to the + terminal of the bottom battery, and the red to the -3 terminal of the bottom battery.

To install the $1\frac{1}{2}$ -cell simply remove the plate and spring on the back of the 026 case. The battery then slips in very easily.

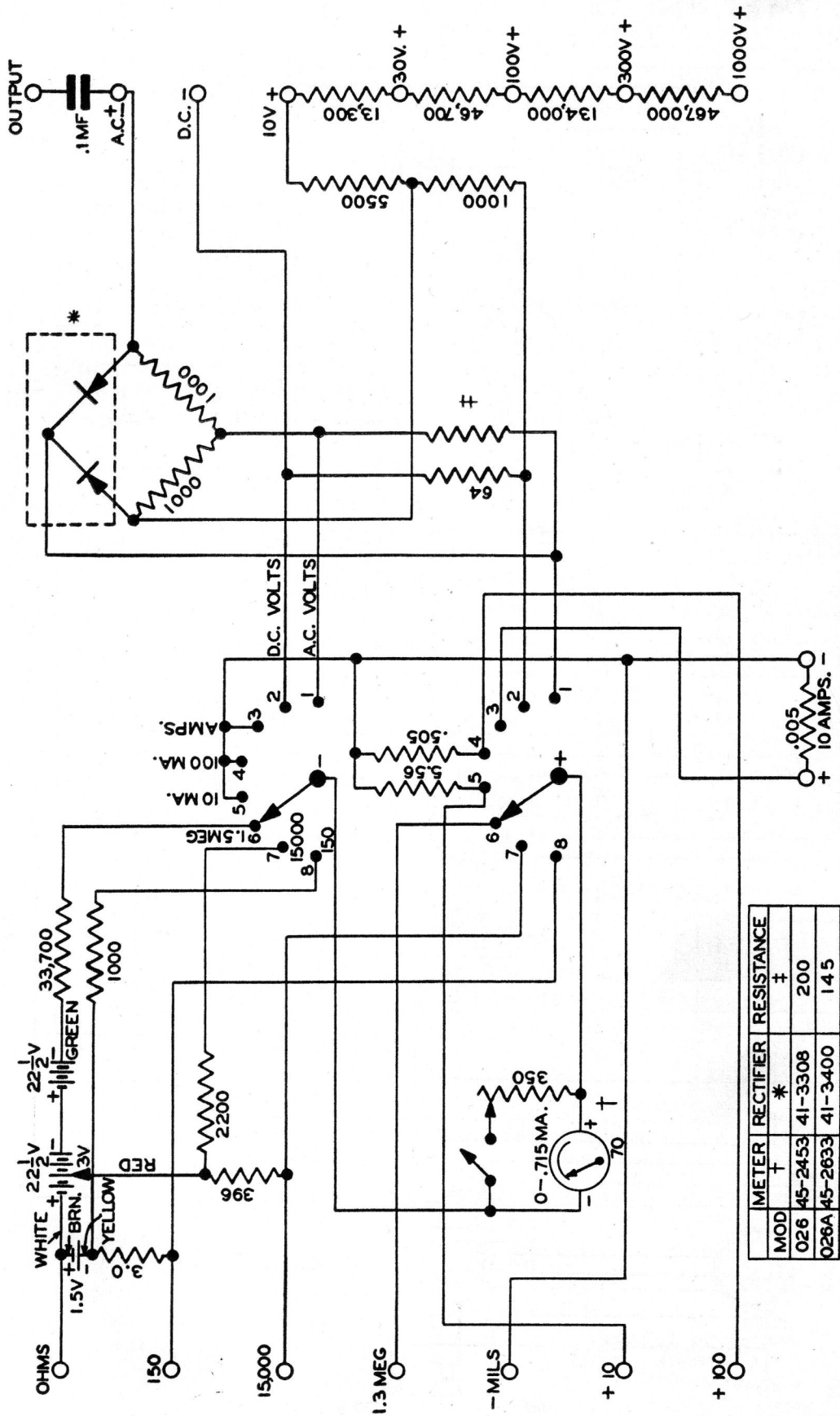

PHILCO MODELS 026, 026A VOLT-OHM-MILLIAMMETERS (SCHEMATIC DIAGRAM)

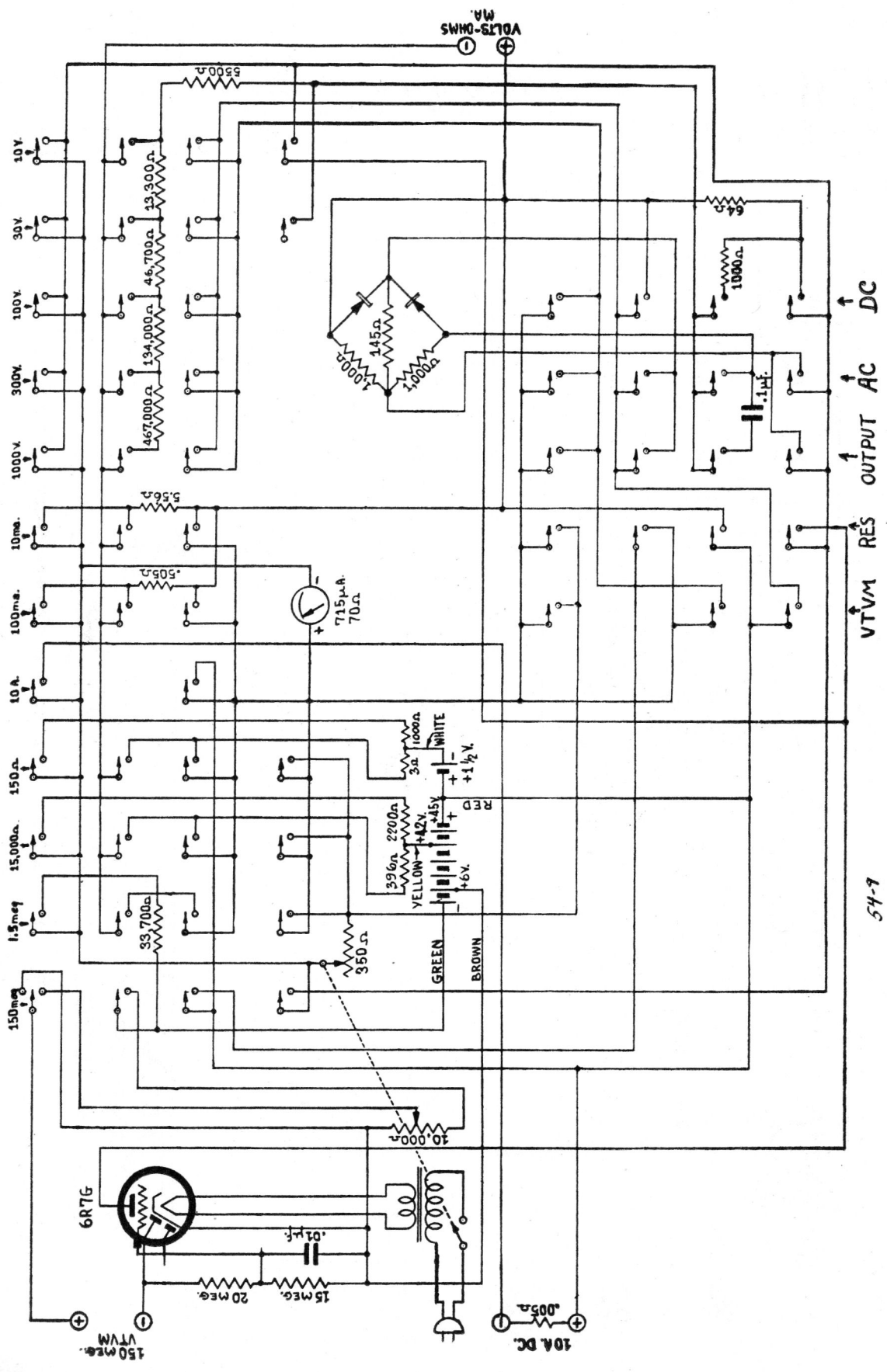

54-1

PHILCO MODEL 027 VACUUM-TUBE VOLTMETER (SCHEMATIC DIAGRAM)

PHILCO CIRCUIT TESTERS

PHILCO MODEL 028 VACUUM-TUBE VOLTMETER

The Philco Model 028 is a combination vacuum tube voltmeter, voltmeter (A.C. and D.C.), milliammeter, ammeter, output meter, and capacity meter.

The vacuum tube voltmeter circuit contains a 1A7G tube and is energized by batteries. The following ranges are available for tests:

Volts: 10, 30, 100, 300, 1000 A.C., D.C. or Output.
Milliamperes: 10, 100 D.C.
Amperes: 10 D.C.
Resistance: 150, 15,000 ohms, 1.5 megohms.
Vacuum Tube Voltmeter: 10 volts, A.C. or D.C.

All functions of this instrument are controlled by three switches. The switch located on the side of the case turns the vacuum tube voltmeter circuit on and off. The left switch on the front of the panel selects the meter functions, and the right switch is used in adjusting the ohmmeter to the zero point when the test leads are shorted. All D-C voltages are measured on the black scales of the meter, and all A-C voltages are measured on the red scales of the meter.

A-C VOLTMETER

1. To measure A-C volts, turn the left selector knob to the "A.C." position, and the ohmmeter knob to the "Off" position (extreme left).
2. Insert the pin tip of the black test lead in the jack marked "A.C.±" and the pin tip of the red test lead into the red jack of the voltage range desired.
3. Read the A-C voltage ranges on the red scales of the meter as follows: 0 to 10, 0 to 100 and 0 to 1000 on the 0 to 10 red scale. Multiply by 10 for 100 volts and by 100 for 1000 volts. The bottom red scale is used for 0 to 30 and 0 to 300 volts. Multiply by 10 for 300 volts on this scale.

D-C VOLTMETER

1. Turn the selector knob to the "D.C." position and the ohmmeter knob in the "Off" position.
2. Insert the pin tip of the black test lead in the jack marked "D.C.—" and the red test lead into the red jack of the voltage range desired. These ranges are read on the meter as follows: 0 to 10, 0 to 100 and 0 to 1000 volts D-C top black scale (0 to 10). When using either the 100 or 1000-volt ranges, multiply the readings on the scale by 10 and 100 respectively.

The 0 to 30 and 0 to 300-volt ranges are read on the black 0 to 30-volt scale. Multiply the reading on this scale by 10 for 300 volts.

D-C MILLIAMMETER

1. Turn the selector knob to the range desired "10 mils" or "100 mils" and insert the black test lead in the black (mils—) jack. The red test lead is placed in the 10 or 100 jacks beneath the "Mils" jack depending on the range desired. The ohmmeter knob must be in the "Off" position.
2. Read milliamperes on the 0 to 10-volt black scale. Multiply by 10 when using the 100-mil range.

D-C AMMETER

1. Turn the selector switch to "Amps" position and connect the test leads to binding posts marked "10 amps."
2. Read current on the 0 to 10-volt scale (black).

MEASURING RESISTANCES

(150 ohms, 15,000 ohms, and 1.5 megohms)

1. Set the selector switch to the resistance range desired (150, 15,000, or 1.5 megohms).
2. Insert the black test leads into the jack marked "Ohms" and the red test lead into the "150", "15,000" or "1.5 meg." jack depending on the position of the selector switch.
3. Turn the ohmmeter knob "On" (clockwise), then shorting the test leads, adjust the knob until the meter reads "zero" ohms on the top black scale. This is indicated by the needle being on the extreme right index line of the top scale. Resistance values are read on the top scale.
4. If the 0 to 15,000-ohm range is used, add two zeros to the meter readings. For the 0 to 1.5 megohm range add four zeros to the meter readings.

OUTPUT METER

1. Turn the selector switch to the "A.C." position. Insert one of the two special tube adapter leads into the jack marked "output" and the other lead into any one of the red jacks directly below depending on the strength of the signal to be measured. The other ends of the leads are then connected to the plate and cathode of any audio tube or across the speaker voice coil.

PHILCO CIRCUIT TESTERS

VACUUM TUBE VOLTMETER

The Vacuum Tube Voltmeter is a highly sensitive instrument used for Voltage Measurements of the R-F, I-F and Audio circuits of receivers in cases where no current should be drawn by the meter.

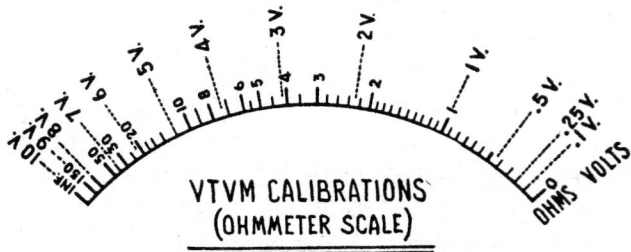

This instrument is useful in high impedance or high resistance circuits for all measurements of alternating or direct current voltages of small magnitude.

When using the Philco Model 028 Vacuum Tube Voltmeter, a few precautions should be observed. These are listed below and should be carefully followed in order to insure accuracy.

1. Measurement of D-C voltages are made by connecting the short lead to Negative (-) and the long lead to Positive (+). Before connecting the leads to the D-C source under test, adjust the pointer for zero reading by shorting the leads together and adjusting the "0 Adj." knob until the pointer is on the right hand "0" of the top scale.
2. A-C voltage measurements of R-F, I-F and A-F circuits are made with the short lead and clip connected to that point in the circuit with the highest A-C potential with respect to ground (example: grid or plate). In A-C work the length of this lead is critical and should not be increased. A 3000-mmfd. condenser, such as Philco Part No. 30-1028, should be connected in series with this lead and the circuit being tested.
3. In measuring all R-F, I-F or A-F voltages, the Vacuum Tube Voltmeter leads should be connected as outlined above across the voltage source under test when no voltage is present in the source. The zero adjustment of the Vacuum Tube Voltmeter should be made under these conditions. If the source under measurement is a tuned circuit it should be repadding after connection of the Vacuum Tube Voltmeter to correct for the detuning effect of the leads. After zero adjustment and repadding, the position of the leads should not be disturbed.

4. No potential higher than 50 volts should be connected to the Vacuum Tube Voltmeter terminals.
5. No cable or shielded leads should be connected to the two test leads of the Vacuum Tube Voltmeter.

OPERATION OF THE VACUUM TUBE VOLTMETER

1. Turn the switch located on the side of the case to "on" position (clockwise). Then set the Selector Switch (front of panel) to the "1.5" megohm position.
2. Clip the two V.T.V.M. test leads to the circuit being tested and make zero adjustment of the pointer by turning the "0 Adj." knob and following the precautions as indicated in paragraphs one, two and three under "Vacuum Tube Voltmeter" above.
3. After these connections and adjustments are made, the voltage can be measured by using the top resistance scale in conjunction with the calibrated chart (V.T.V.M. chart).

CAPACITY METER

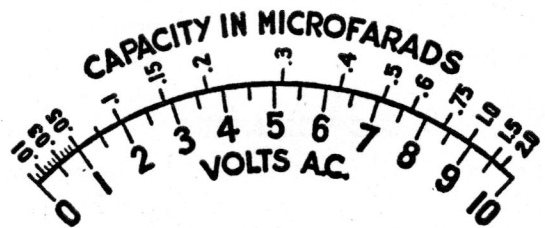

CALIBRATION CHART FOR CAPACITY

To measure capacity it will be necessary to use a Philco potentiometer and a cartridge-type resistor, value shown in diagram herewith.

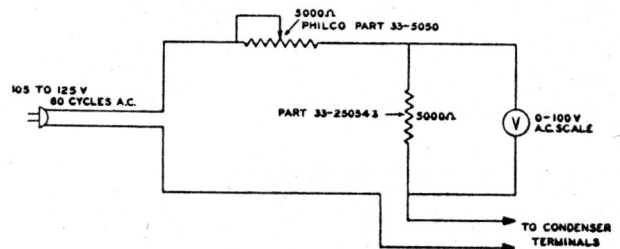

EXTERNAL CIRCUIT FOR CAPACITY METER

Make the connections as shown in the diagram below, using the 0-100 volt A-C scale of the meter and adjusting potentiometer for 100 volts with the test prods (leading to condenser to be tested) shorted together. Use calibration chart below for capacity test.

PHILCO CIRCUIT TESTERS

REPLACING BATTERIES

Model 028 requires two $22\frac{1}{2}$ -volt dry battery units, size 4" x 3" x $2\frac{1}{2}$ ", with a 3-volt tap and one $1\frac{1}{2}$ -volt flashlight cell, size No. 2, for operation of the ohmmeter circuit. This battery should be checked occasionally to make sure that it is in good condition.

To install the batteries, take off the front instrument panel from the case by removing the screws around the outer edge of panel. The $22\frac{1}{2}$ -volt batteries are then secured to the inside top and bottom of the case by clamps which are held in place by bolts and nuts. Four holes are provided in the case; two in the back, one in the top and one in the bottom, for attaching these clamps.

The batteries should be replaced when their voltage drops below 17 volts (indicated by inability to obtain a "zero adjustment").

Connect the + terminal of the top battery to the $-22\frac{1}{2}$ terminal of the bottom battery. Connect the green

lead to the $-22\frac{1}{2}$ terminal of the top battery, the white lead to the + terminal of the bottom battery, and the red to the -3 terminal of the bottom battery.

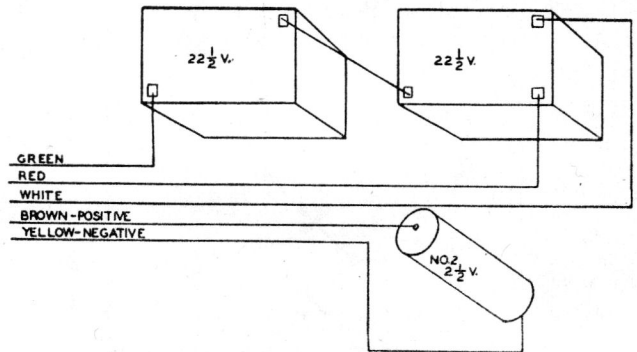

WIRING OF BATTERIES

To install or replace the $1\frac{1}{2}$ -volt cell simply remove the plates and spring on the back of the 028 case.

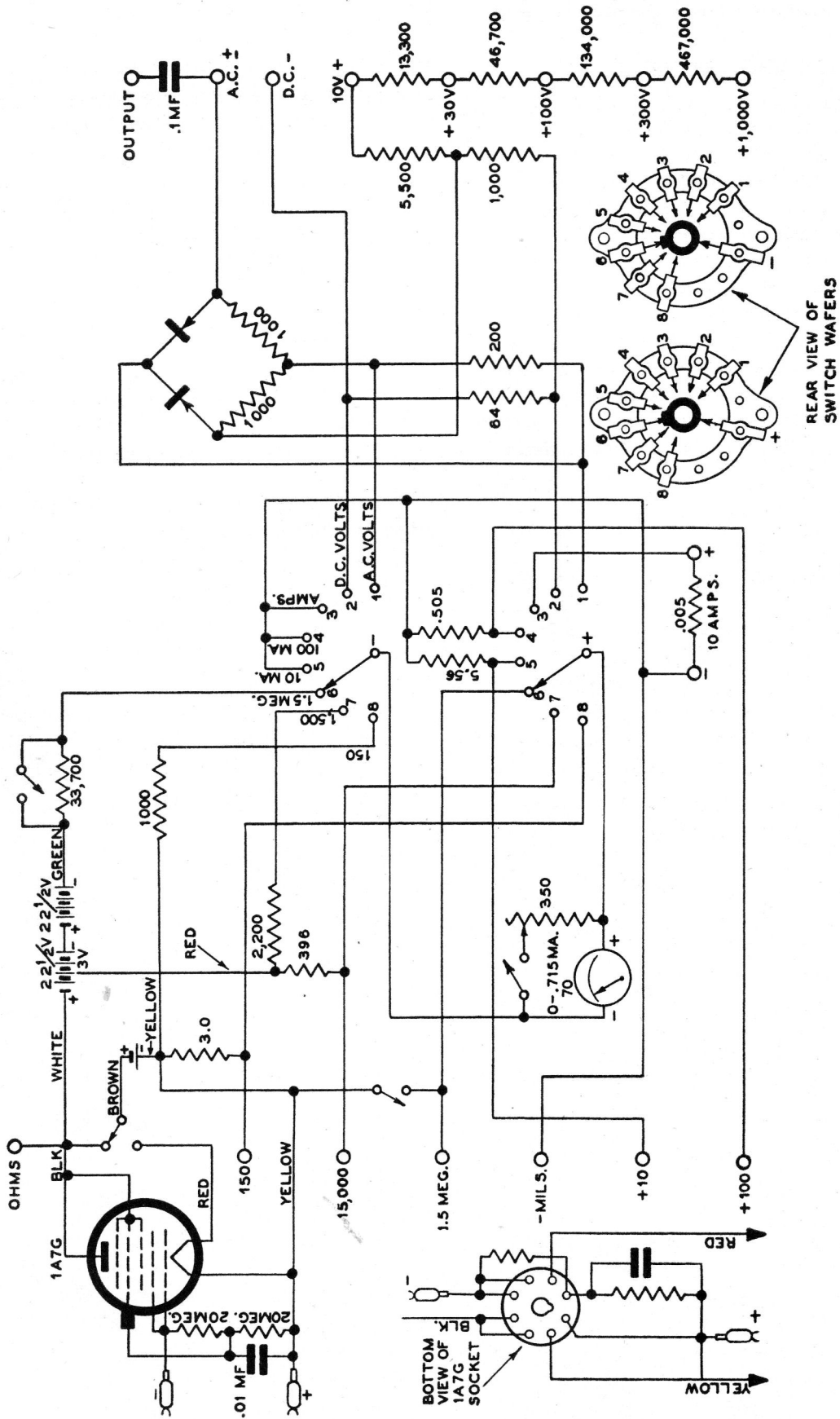

PHILCO MODEL 028 VACUUM TUBE VOLTMETER (SCHEMATIC DIAGRAM)

PHILCO MODEL 030 DYNAMIC TESTER

The Philco Dynamic Tester is extremely useful in locating defects in any type of radio with a minimum of time and effort. It operates on the principle of amplifying and reproducing a signal taken from any circuit of a radio in which a signal is normally present. It is easy to use, requiring no tuning to amplify signals of any frequency (radio, intermediate or audio frequency).

The Dynamic Tester not only indicates the presence of a signal but gives a comparative idea of its intensity. It can also be used to test public address amplifiers, microphone circuits and phonograph pickup circuits. The tester is designed to operate on a 115-volt, 50 to 60 cycle A-C power supply.

TUBE COMPLEMENT

The tester contains four tubes. Three of the tubes (types 7C7, 7A5 and 7Y4) are mounted in the tester case, and a 6F5GT tube in the test prod assembly.

The complete test prod assembly including the tube it encloses can be removed from the socket at the end of the cable. The tube can be removed from the shield by grasping one of the base pins or locating pin with a pair of pliers. In replacing this tube in the shield, it is necessary to remove the switch from the end of the shield to connect the grid clip to the control grid cap of the tube.

Connecting for Operation

1. Connect the dynamic tester to a 115-volt, 50 or 60 cycle power supply. Turn the attenuator control to the right until the power switch is in the "ON" position.
2. Connect the ground wire clip to the radio chassis. In the case of an A.C.-D.C. set, it might be necessary to reverse the power plug to either the dynamic tester or the radio under test or both for a minimum of hum pickup in the dynamic tester.
3. Turn the radio "ON", and tune in a strong local station. If the radio is inoperative, turn the dial to the setting for a local station. If a strong local station is not on the air, connect a signal generator and tune in any audio modulated R-F signal in the broadcast or short-wave band. The following procedure should be used in testing the radio and other special apparatus.

TEST PROCEDURE

Beginning with the input terminal (antenna or loop) touch the test prod to the various points at which a signal should be present, particularly the grid and plate of each

amplifier tube. These various test points are indicated in the "Testing Signal Circuits" procedure and schematic diagram.

At the R-F end of the set, the signal level switch on the test prod assembly should be kept in the "High" position toward the tip. The attenuator should be turned all the way on when testing in the R-F sections of the set and gradually retarded as the audio amplifier circuit is approached. As the test prod is moved from the test points in the R-F section toward the audio circuit the signal should increase in volume. When testing the audio amplifier, the switch on the prod assembly should be turned to the "LOW" position.

When it is impossible to obtain a normal signal at some particular amplifier stage, testing for the exact location of the trouble can be completed by touching the test prod to the adjacent parts of the circuit.

TESTING SIGNAL CIRCUITS

1. ANTENNA CIRCUIT TEST

- a. Place test prod at point "A"; with the attenuator on full, the signal should be heard weakly. The band switch should be tested in broadcast and S.W. positions, with a signal tuned in for each position.

2. R-F CIRCUIT TEST

- a. Apply test prod at point "B" (plate of R-F Tube); an increase in signal strength should be noted. When testing the S.W. band a signal should be tuned in above the middle of the tuning range (tuning condenser at least half meshed).

3. CONVERTER CIRCUIT (1st Detector Stage)

- a. Connect test prod to point "D" (grid signal should have same signal strength as point "B").
- b. Attach prod to point "E" (plate). The signal should increase greatly over point "D" (grid).

4. OSCILLATOR CIRCUIT

- a. Touch test prod to oscillator grid or plate "G". Momentarily short circuit the plate of oscillator section of gang with metallic instrument or wire. A click should be heard in the speaker of the tester when the short is applied and also when it is removed.

5. I-F CIRCUIT

- a. Connect prod to point "H" (grid I.F.). Signal should be approximately the same as at point "E".

PHILCO CIRCUIT TESTERS

- b. Apply prod to point "J" (plate of I-F tube). Signal should increase in strength over point "H" grid.
6. SECOND DETECTOR—A.V.C.
- a. Attach prod to diode plate, point "L". Signal should be heard.
 - b. Apply test prod to points "M" and "U". A signal should NOT be heard at either of these points. If signal is heard there is a possibility of the A.V.C. bypass condenser being open.
7. FIRST AUDIO STAGE
- a. Apply test prod to high end of volume control point "N"—push switch on test prod to "LOW" position. A weak audio signal should be heard.
 - b. Apply test prod to point "O" (volume control). Volume control of radio in maximum position, signal should be heard with equal strength of point "N".
 - c. Attach test prod to point "P" (plate of audio tube). Signal will greatly increase in strength if tube and associated circuit preceding are normal.
 - d. While the illustrative diagram shows the second detector A.V.C. and first audio stages in one tube, the same test as given above is used when these circuits are in separate tubes.
- In some sets an intermediate audio stage will be found. In these radios the test prod should be attached to the grid and plate of the second audio stage and the signal strength noted. The signal should have greater gain than when tested at the first audio stage.
8. AUDIO OUTPUT CIRCUITS
- a. Connect test prod to point "Q" (grid). Signal should have same gain as was noted at point "P".
 - b. Attach prod to point "R". Signal should have tremendous gain over the input point "Q".
 - c. Apply test prod to point "S". Signal should be lower in volume than at point "R", depending upon ratio of transformer.

ADDITIONAL USES AND SPECIAL TESTS

While the tester is primarily intended to indicate the presence of a signal in a circuit where it should normally be, it can also be used to detect signals in circuits in which the signals are supposed to be excluded through the action of bypass condensers. In addition, it will be found useful in checking any special apparatus which develops an R-F or audio signal.

1. OPEN BYPASS CONDENSERS

- a. Automatic Volume Control (A.V.C.) Circuit.
By applying the test prod to points "M" and "U" the filtering condition of the A.V.C. circuit can be checked. A signal SHOULD NOT be heard at either of these points. If a signal is heard it will indicate trouble in the filter condensers or resistors of the A.V.C. circuit.
- b. Screen grid circuits.
Application of the test prod to any screen grid tube contact will indicate the filtering action of the bypass condensers. Under normal operation a signal should NOT be present. If the signal appears in these circuits it will indicate trouble in the bypass condensers (being open or partially open).

2. HUM (HUM FILTER CONDENSERS)

- a. Abnormal hum can be located with the tester by applying the test prod to points "O" and "T" in the audio filter circuit. If abnormal hum is heard at any of these points it will indicate trouble in the filter resistors or bypass condensers. Hum comparison tests can be made in any circuit with the tester.

3. LEAKY COUPLING CONDENSERS

(Between Audio Stages)

The Dynamic tester will also be found helpful in locating leaky coupling condensers (noisy) in audio circuits such as the condenser between points "P" and "Q". If this condenser is leaky the signal will be noisy or weak at point "Q". If the condenser is shorted no signal will be heard at "Q". This test also is useful in testing coupling condensers in the R-F section such as points "B" and "D".

4. PHONOGRAPH CIRCUITS

The Dynamic tester will also test phonograph pickup circuits. The test prod is applied to the various connections in the phonograph circuit beginning at the pickup and working back through the audio amplifier stage to the speaker.

5. MICROPHONE CIRCUITS

The Dynamic tester works equally well in testing microphone circuits. The procedure being the same as with phonograph circuits, beginning, however, with the microphone connections and testing through the various mixer and audio stage signal points.

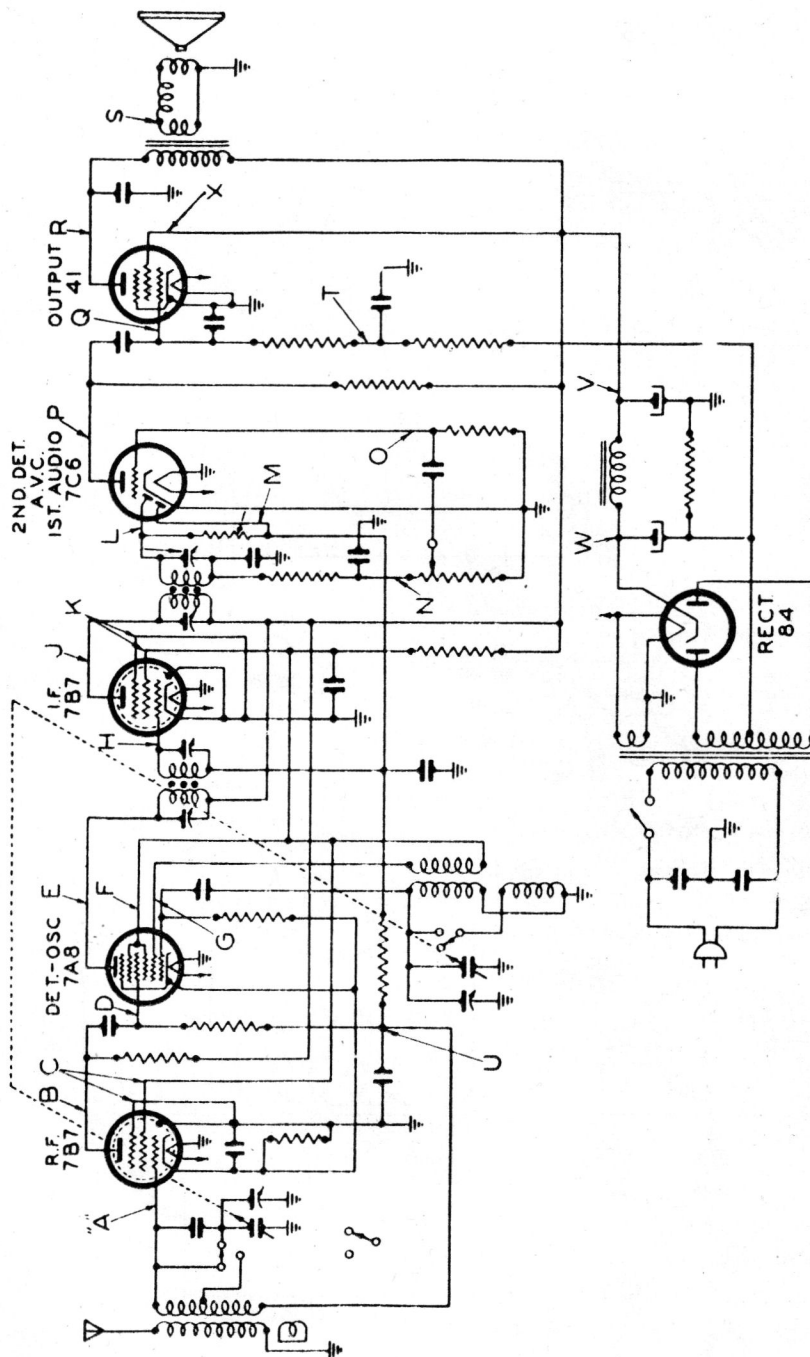

TYPICAL RADIO RECEIVER CIRCUIT

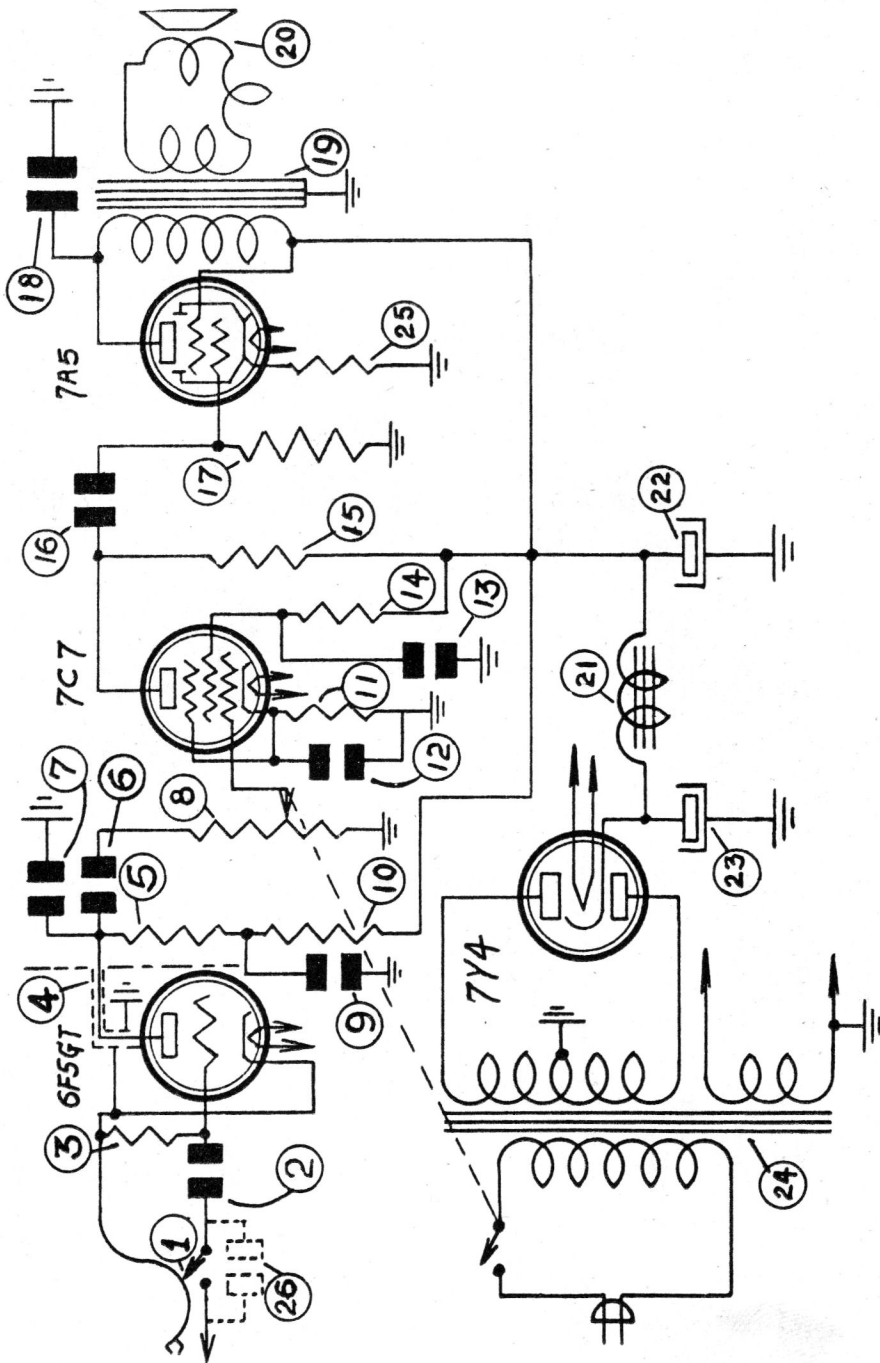

PHILCO MODEL 030 DYNAMIC TESTER
(SCHEMATIC DIAGRAM)

Section II

PHILCO SIGNAL GENERATORS

Philco Model 016

Philco Model 024

Philco Model 048A

Philco Model 070

Philco Model 077

Philco Model 088

Philco Model 091

Philco Model 177

PHILCO SIGNAL GENERATORS

PHILCO MODEL 016 SIGNAL GENERATOR

Model 016 is an A.C.-D.C. operated push-button controlled signal generator that provides accurate standard I-F and R-F signals. The signals supplied by this generator cover the standard padding frequencies used in aligning all commercial radio receivers. Six push-buttons are provided and operate on two frequency bands. These bands are controlled by the "I.F.-R.F." band selector switch. Each button is preset at the factory to a standard frequency setting. Any of the frequency settings, however, can be changed by removing the escutcheon plate which covers the twelve compensators, and resetting the compensators (I.F. or R.F.) opposite the button to be changed. The fundamental R-F and I-F frequencies covered by each button are as follows:

I-F FREQUENCIES

Button	Range	Standard Setting
No. 1	155 to 390 K.C.	175 K.C.
No. 2	155 to 390 K.C.	260 K.C.
No. 3	220 to 450 K.C.	350 K.C.
No. 4	240 to 570 K.C.	455 K.C.
No. 5	240 to 570 K.C.	460 K.C.
No. 6	290 to 620 K.C.	470 K.C.

R-F FREQUENCIES

Button	Range	Standard Setting
No. 1	560 to 630 K.C.	580 K.C.
No. 2	850 to 2000 K.C.	1000 K.C.
No. 3	1100 to 2400 K.C.	1400 K.C.
No. 4	1300 to 2800 K.C.	1600 K.C.
No. 5	1300 to 2900 K.C.	2500 K.C.
No. 6	1800 to 3300 K.C.	3000 K.C.

NOTE: Short-wave frequencies of 5.0-7.5 and 10.0 Megacycles are obtained by using the harmonics of the fundamental frequency of push-button No. 5. Short-wave frequencies of 6.0, 9.0, 12, 15, and 18 M.C. can also be obtained by pressing push-button No. 6 and using the harmonics of the fundamental frequency of this push-button.

POWER SUPPLY

The signal generator is designed to operate on a 115-volt A-C or D-C power supply. The power circuit is thoroughly shielded and filtered to prevent leakage into the power line of the signal produced by generator.

ATTENUATOR

The signal strength of the R-F and I-F frequencies is controlled from a maximum to a minimum value by a "High-Low" output switch (lower left corner of generator) and a continuously variable "attenuator" control (lower right corner of generator). The output circuit is designed so that no damage will result should either one of the generator output leads come in contact with the A-C line, as might happen in connecting to some A.C.-D.C. sets. In addition, variation of the attenuator controls will not affect the frequency of the signal.

OPERATION

- Setting the Controls:
 - Insert power cord into a 115-volt A-C or D-C power receptacle.
 - Connect the clip of the generator shielded output wire to the circuit to be tested. Connect the ground wire of the generator output cable to the radio chassis or ground terminal. When connecting the output cable, the point of connection and dummy aerial should be used as specified in the manufacturer's padding procedure of the receiver to be adjusted.
 - Slide the "I.F.-R.F." switch to the position desired, depending on which circuit in the receiver is to be adjusted.
 - Press "IN" the push-button controlling the frequency required.
 - Slide the "High-Low" output switch (lower left corner) to the "UP" position. In this position, the maximum signal output of the generator is obtained. This is the desired position for preliminary padding of a receiver. For final, accurate padding, slide the "High-Low" switch to the "Down" position for a weak signal.

The strength of the signal output in either position of the "High-Low" switch is controlled from maximum to minimum by the variable attenuator located on the lower right side of the generator.

- Aligning I-F Circuits:

When adjusting the I-F circuits, a .1 mfd. condenser should be connected between the shielded output lead and the point in the I-F circuit where the signal is to be applied. It is advisable, however, in all cases, that the value of the coupling capacity be as specified in the manufacturer's padding procedure of the receiver being adjusted.

PHILCO SIGNAL GENERATORS

3. **Aligning R-F Circuits:**

In aligning the R.F. circuits of receivers designed for a standard type aerial, connect a 200-mmfd. condenser between the output lead of the signal generator and the aerial terminal of the receiver. When aligning the short-wave band, replace the above condenser with a 400-ohm carbon resistor.

4. **Aligning Receivers with Special Aerial Circuits:**

When aligning receivers designed for a doublet aerial system or any aerial using a matched transmission line (such as the Philco High Efficiency Aerial), the signal generator output cable should be connected as follows: Connect the high side (shielded wire) of the signal generator output cable through a 100-ohm resistor to the ungrounded terminal of the transmission line on the radio. Connect the ground wire of the output cable to the radio chassis ground post.

5. **Aligning Loop Aerial Radios:**

To align radios using a loop aerial, a test loop should be connected to the output cable of the signal generator. The test loop can be made from a few turns of wire approximately 12 inches in diameter, or a Philco Auxiliary Loop Aerial, Part No. 45-2808, can be used for this purpose.

After the test loop is connected to the output cable of the generator, it should be placed approximately one foot from the loop aerial of the receiver.

CHECKING SET FOR CORRECT PADDING

A rapid check is easily made to determine if the high-frequency circuits of a radio are correctly padded to the true signal and not to the image signal by merely tuning

the radio to the harmonics of the No. 6 R-F button (6.0-9.0-12.0-15.0-18.0 megacycle) and noting that the signals appear at their correct dial positions.

When a set is incorrectly padded to the image frequency, the next lowest signal will be much weaker in strength and approximately $\frac{1}{2}$ megacycle off frequency.

This check is easily made since the signal generator need only be set but once.

CHANGING FREQUENCIES OF PUSH-BUTTONS

The push-buttons are preset at the factory to standard I-F and R-F frequencies. These frequencies, however, can be changed to other values within the limits as listed above. To do this, proceed as follows:

1. Connect the output cable of the signal generator to the aerial connection of a radio set. Remove the escutcheon from the push-buttons. A row of padders will be found on each side of the push-buttons.
2. The left-hand row of padders control the frequency range of the I-F band, and the right-hand row of padders, the R-F band.
3. To change the frequency of any push-button, insert an insulated padding screw driver into the I-F and R-F padder screw adjacent to each push-button, and turn in the direction necessary to obtain the frequency desired.
4. When doing this, the radio receiver dial should be turned to the frequency desired, or to a harmonic of the frequency in case of I-F frequency. To do this correctly, a radio receiver that is calibrated accurately should be used.

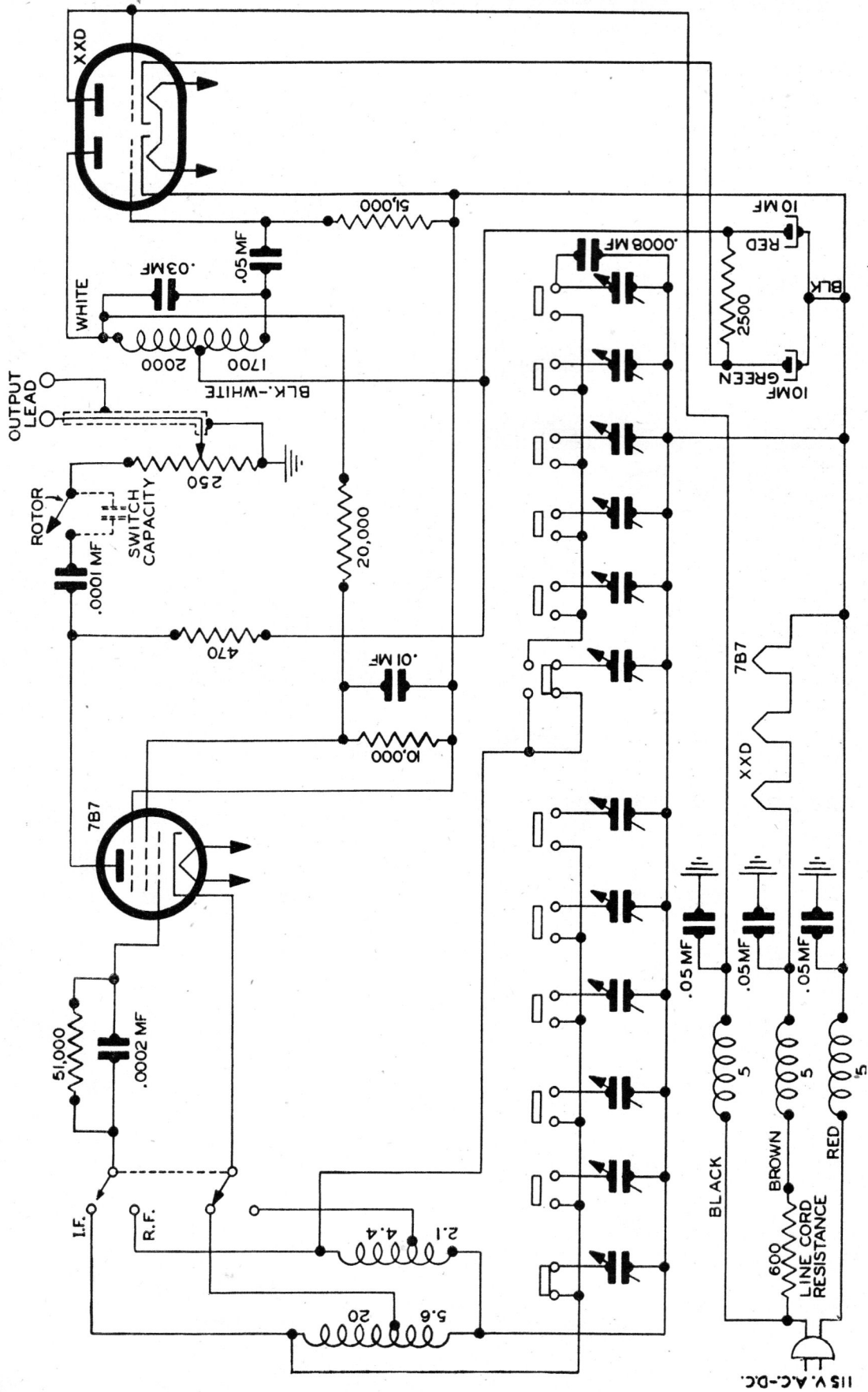

PHILCO MODEL 016 SIGNAL GENERATOR (SCHEMATIC DIAGRAM)

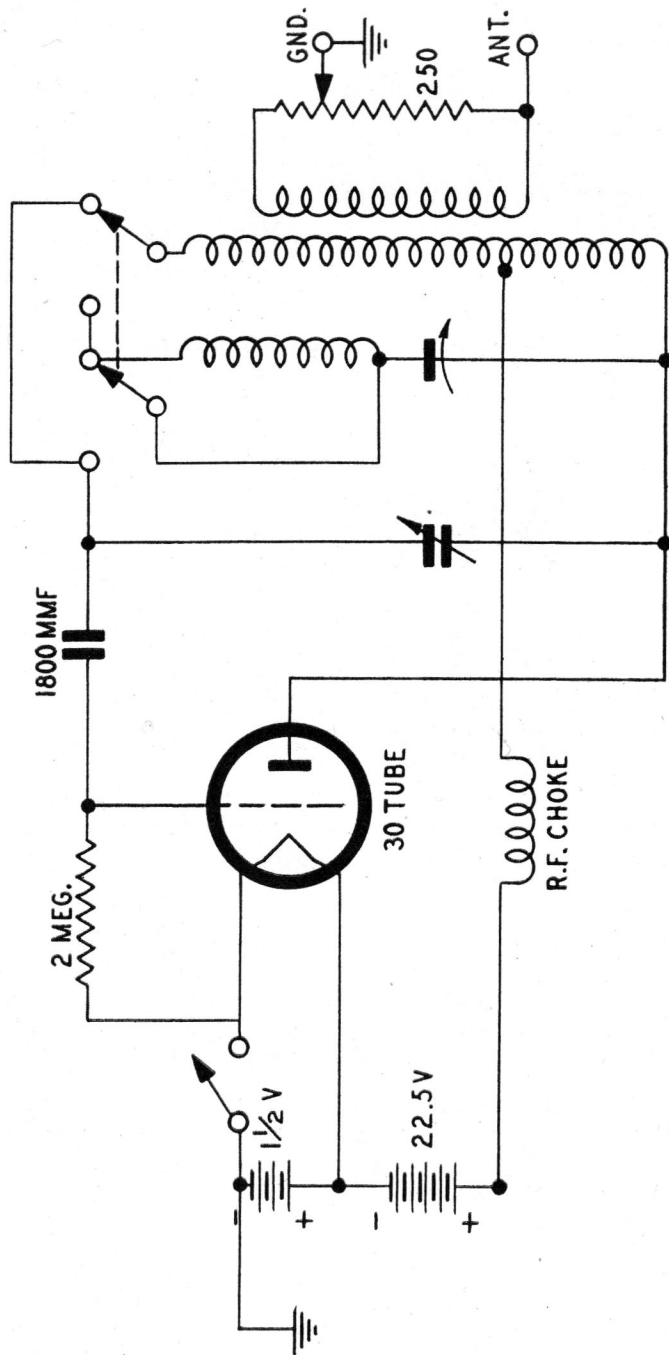

PHILCO MODEL 024 SIGNAL GENERATOR
(SCHEMATIC DIAGRAM)

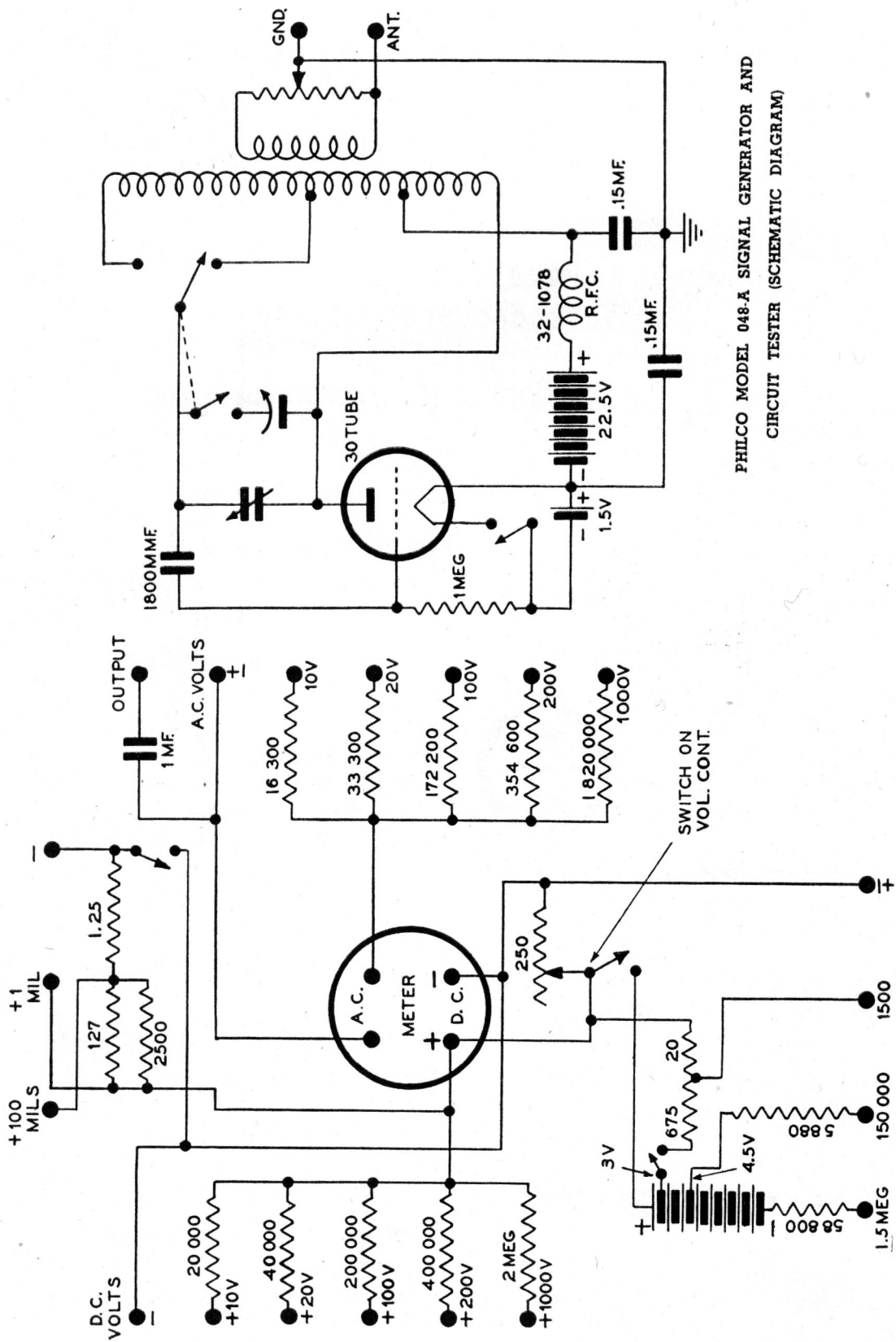

PHILCO MODEL 048-A SIGNAL GENERATOR AND
CIRCUIT TESTER (SCHEMATIC DIAGRAM)

PHILCO SIGNAL GENERATORS

PHILCO MODEL 070 SIGNAL GENERATOR

Philco Model 070 Signal Generator is a precision test instrument built to a high standard of accuracy, incorporating features found only in laboratory test equipment. Advanced circuit design and rigid mechanical construction insure permanent calibration under the most severe operating conditions. Every requirement necessary for accurate alignment of the Intermediate and Radio Frequency circuits of a receiver has been taken into consideration in the design of this instrument. The high quality of material and construction characteristic of Philco devices assures the serviceman of a scientific and reliable test instrument.

CIRCUIT DESCRIPTION

One type 6J7G tube is used as an oscillator, one type 6J5G tube as the modulation generator, and one 6X5G as a rectifier. The use of separate tubes to generate the R-F and audio signals provides unusual frequency stability. The output of the generator is optionally audio frequency, modulated R.F., or unmodulated R.F. As normally used, the signal is modulated at 400 cycles (accepted throughout the radio industry as the standard test signal). A specially designed control marked "Modulation", located on the right-hand side of the generator, combines the power and modulation control switches. This control is independent of all other controls so that power may be applied to the generator, or the modulator circuit turned off without affecting the frequency of the oscillator or changing the output setting.

POWER SUPPLY

An improved power circuit developed by Philco for operation on a 105 to 130-volt, 50 to 60 cycle power supply reduces frequency shift of the oscillator circuit due to variation of the line voltage. The power circuit is thoroughly shielded and filtered to prevent leakage of the signal from the generator into the power line.

FREQUENCY RANGE

Six (6) accurately calibrated, full vision, overlapping scales, covering a frequency range of 115 KC. to 70 MC. assure the complete coverage of the I.F., broadcast, and short-wave ranges of modern receivers. Each band covers a frequency range as follows:

Band "A".....	115 to 350 K.C.
Band "B".....	350 to 1050 K.C.
Band "C".....	1050 KC. to 3.5 MC.
Band "D".....	3.4 to 12 MC.
Band "E".....	11 to 37 MC.
Band "F".....	22 to 74 MC.

Each scale is selected by means of the "Band Switch" (upper left-hand corner of the panel), which is marked with the corresponding letters, A, B, C, D, E, and F, of the scales. The last band is calibrated from harmonics of Band "E". Precise frequency settings are made by a new magnifying NON-Radiating Pointer which has two index lines that eliminate inaccuracies in setting the pointer to the frequency desired. The pointer is rotated by a vernier ball-bearing reduction drive.

AUDIO OUTPUT

An audio signal of 400 cycles is provided at the output terminals when the band switch is turned to the position marked "Audio". The strength of this signal is determined by the settings of the multiplier and attenuator controls. By applying this 400-cycle signal to any portion of an audio system, a thorough check of its amplifying ability is obtained.

ATTENUATOR

Attenuation of the output signal from a maximum to a minimum value is obtained by means of a completely shielded ladder-type attenuator, marked "Multiplier", and a continuously variable "Attenuator" control. The output control provides a constant output impedance of 100 ohms between the output terminals marked "Med." and "Gnd." and provides attenuation of the signal to an extremely low value that will provide a weak input signal to the most sensitive radio receiver. A further advantage of this attenuator is that the frequency of the signal is not affected when the output controls are varied.

R-F AND I-F ADJUSTMENTS

Adjusting Controls

1. Set the "Modulation" Control to the position marked "Mod on". The control in this position applies power to the generator and at the same time turns on the modulator tube. If an unmodulated signal is desired, turn this control to the position marked "Mod off".

2. Insert the antenna lead pin tip of the output cable in the "Med." jack. Place the ground wire tip of the cable in the jack marked "Gnd." The terminal marked "High" should be used only for preliminary padding when greater signal strength is desired. For final accurate

PHILCO SIGNAL GENERATORS

padding the terminal marked "Med." should always be used.

3. Set the tuning indicator of the signal generator to the frequency desired; then turn the band switch to the letter of the scale on which the frequency appears.

4. Attenuation of the signal is obtained by the multiplier control marked 1, 10, 100, 1000. Set the knob at the point which will give sufficient signal input to the receiver. Complete control of this level from maximum to minimum is then obtained by the variable "attenuator" control located above the "multiplier" control. When the "High" jack is used the multiplier control has no effect on the signal.

ALIGNING I-F CIRCUITS

5. When adjusting I-F circuits connect a 0.1 mfd. condenser between the antenna lead of the output cable and the grid of the tube in the receiver.

ALIGNING R-F CIRCUITS

In aligning the R-F circuit of broadcast bands in receivers designed for a standard type aerial, connect a 200 mmfd. condenser between the antenna lead of the signal generator and the antenna terminal of the receiver. In aligning the short wave bands replace this condenser with a 400-ohm carbon resistor.

ALIGNING RECEIVERS WITH SPECIAL AERIAL CIRCUITS

When aligning receivers designed for the Philco High Efficiency Aerial, or receivers using a doublet aerial system with a transmission line, connect the output cable of the signal generator directly to the transmission line terminal of the receiver. In aligning receivers of this type the output cable must be connected to the "Med." and "Gnd." jacks.

AUDIO SIGNAL TEST

1. Turn the "Band Switch" to "Audio".
2. Set "Modulation" switch to "Mod on".
3. Insert the output cable pin tips into the "High" and "Gnd." jacks. The other end of the wire in the "High" jack is connected through a .1 mfd. condenser to any section of the audio circuit to be tested, i.e., 2nd det. grid; 1st audio grid or output tube grid.
4. Attenuation of the audio signal is then obtained by the "Attenuator" control. If a weaker audio signal is desired, insert the output pins in the "Med." and "Gnd." jacks. When the "Med." jack is used, the "Multiplier" and "Attenuator" control the audio signal.

DIAL CALIBRATION

In order to calibrate the scales of the dial accurately, the dial indicator must be aligned to track properly with the tuning condenser. To do this proceed as follows: Turn the tuning condenser to the maximum capacity position (plates fully meshed).

With the tuning condenser in this position, loosen the set screws of the indicator collar, being careful not to disturb the setting of the tuning condenser.

Then turn the indicator until the index line of the magnifying pointer is in the center of the three black dots at the left hand side between the scales.

Tighten set screws in this position.

After the dial indicator is set, each scale of the signal generator is adjusted by the individual compensating condensers, locations of which are shown on illustration. Briefly, the method of calibration is to zero beat the generator signal against signals from accurately controlled broadcast stations or short wave stations operating on frequencies near the high frequency end of each scale.

SCALE A: Turn modulation switch to "Mod Off" position. Connect the signal generator output lead to the radio receiver antenna terminal. Now, tune the radio receiver accurately to a station on the standard broadcast band the frequency of which is double that of any frequency between 300 KC. and 350 KC. on Scale A of the signal generator. When the station is tuned, turn the Band Switch knob to "A" and set the indicator of the signal generator to the frequency mark on Scale A that corresponds to $\frac{1}{2}$ the station frequency.

EXAMPLE

If the station frequency is 600 KC., set the indicator of the signal generator to $\frac{1}{2}$ that frequency, or 300 KC. on Scale "A". With receiver and signal generator set in this manner, adjust the compensator for Scale "A" until a whistle or beat note is heard in the receiver. Adjust the compensator until this whistle (beat note) is eliminated, or is made as low as possible. This is the correct adjustment for Scale "A".

SCALE B: Turn the Band Switch knob to "B". Then tune the radio receiver to a station between 850 KC. and 950 KC. Set the signal generator indicator to the frequency on Scale "B" corresponding to the station. Now, adjust compensator "B" for zero beat as given above for Scale "A".

SCALES C, D, and E: These scales are adjusted by using the same procedure given for "B". The Band Switch of the signal generator, however, is turned to the

PHILCO SIGNAL GENERATORS

letter corresponding to these scales and the radio receiver tuned to some station operating on a frequency corresponding to that shown on the high frequency end of each of these scales. On scale "C" the frequency should be between 3.0 MC. and 3.5 MC. On Scale "D" the frequency should be between 10 MC. and 11 MC., and on Scale "E", between 28 MC. and 36 MC. The "F" band is automatically calibrated when the "E" band padder is adjusted. This is due to the "F" band frequencies being a second harmonic of the "E" band.

REPLACING TUBES

Remove the screws holding the front panel to the case and lift panel straight out. The tubes will be found in sockets mounted on small sub-bases. The rectifier (6X5G) is located at the top, and the 6J5G modulation generator and 6J7G oscillator tubes are at the bottom of the panel.

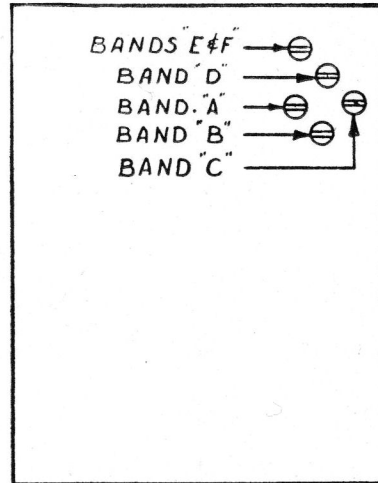

REAR VIEW OF MODEL 070
COMPENSATOR LOCATIONS

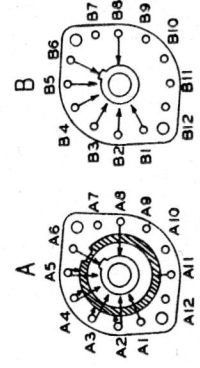
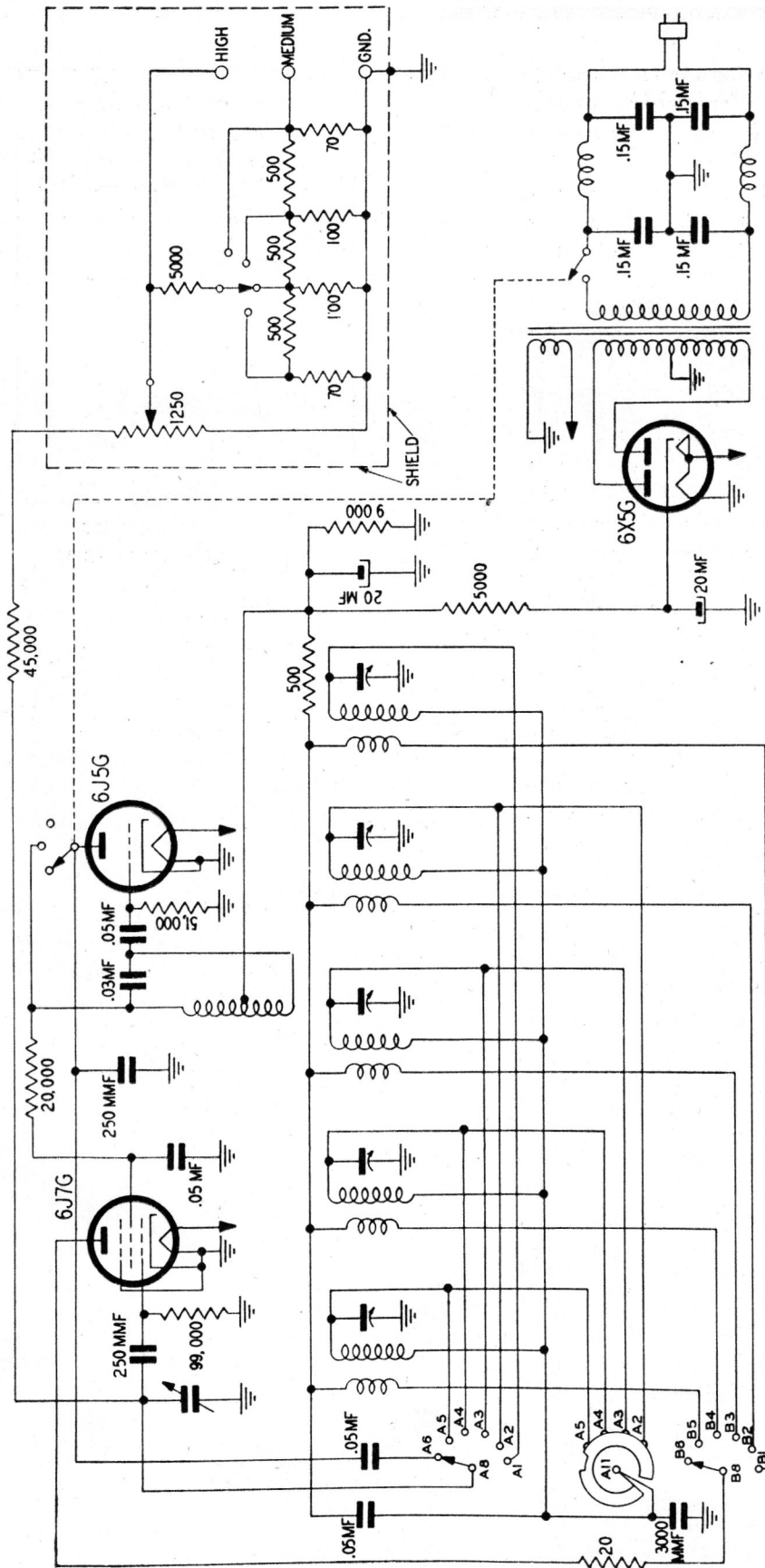

SWITCHES SHOWN IN POSITION NO.1 (AUDIO).
 LETTERS INDICATE POSITION OF WAFERS
 FROM REAR OF CHASSIS.
 SOLID AREA INDICATES REAR OF SWITCH WAFER.
 SHADED AREA INDICATES FRONT OF SWITCH WAFER.

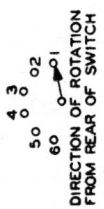

PHILCO MODEL 070 SIGNAL GENERATOR
 (SCHEMATIC DIAGRAM)

PHILCO SIGNAL GENERATORS

PHILCO MODEL 077 SIGNAL GENERATOR

PHILCO MODEL 077 SIGNAL GENERATOR is a precision test instrument built to a high standard of accuracy, incorporating features found only in laboratory test equipment. Advanced circuit design and rigid mechanical construction insure permanent calibration under the most severe operating conditions. Every requirement necessary for accurate alignment of the Intermediate and Radio Frequency circuits of a receiver has been taken into consideration in the design of this instrument. The high quality of material and construction characteristic of Philco devices assures the serviceman of a scientific and reliable test instrument.

FREQUENCY RANGE

Five (5) accurately calibrated, full vision, overlapping scales, covering a fundamental frequency range of 115 KC. to 36 MC. assure the complete coverage of the I-F broadcast, and short-wave ranges of modern receivers. Each scale is selected by means of the "Band Switch" (lower left-hand corner of panel), which is marked with the corresponding letters A, B, C, D, and E, of the scales. Precise frequency settings are made by the knife-edge pointer rotated by a vernier ball bearing reduction drive. The design of this pointer eliminates inaccurate settings.

POWER SUPPLY

An improved power circuit developed by Philco for operation on a 105 to 130-volt, 50 to 60 cycle power supply reduces frequency shift of the oscillator circuit due to variation of the line voltage. The power circuit is thoroughly shielded and filtered to prevent leakage of the signal from the generator into the power line.

ATTENUATOR

Attenuation of the output signal from a maximum to a minimum is obtained by means of a completely shielded ladder type attenuator, marked "Multiplier", and a continuously variable "Attenuator" control. The output control provides a constant output impedance of 100 ohms between the output terminals marked "Med." and "Gnd." and provides attenuation of the signal to a minimum value which is below the level of the most sensitive receiver. A further advantage of this attenuator is that the frequency of the signal is not affected when the output controls are varied.

AUDIO OUTPUT

An audio signal of 400 cycles is provided at the output terminals when the band switch is turned to the position marked "Audio". The strength of this signal is determined by the settings of the multiplier and attenuator

controls. By applying this 400-cycle signal to any portion of an audio system, a thorough check of its amplifying ability is obtained.

CIRCUIT DESCRIPTION

One type 6J7G tube is used as an oscillator, one type 6J5G tube as the modulation generator, and one 6X5G as a rectifier. The use of separate tubes to generate the R-F and audio signals provides unusual frequency stability. The output of the generator is optionally audio frequency, modulated R.F., or unmodulated R.F. As normally used, the signal is modulated at 400 cycles (accepted throughout the radio industry as the standard test signal). A specially designed control marked "Modulation", located on the left hand side of the generator, combines the power and modulation control switches. This control is independent of all other controls so that power may be applied to the generator, or the modulator circuit turned off without affecting the frequency of the oscillator or changing the output setting.

R-F AND I-F ADJUSTMENTS

1. Set the Power-Modulation Control to the position marked "Mod. on." The control in this position applies power to the generator and at the same time turns on the modulation. If an unmodulated signal is desired, turn this control to the position marked "Mod off."

2. Insert the antenna lead pin tip of the output cable in the "Med." jack. Place the ground wire tip of the cable in the jack marked "Gnd." The terminal marked "High" should be used only for preliminary padding when greater signal strength is desired. For final accurate padding the terminal marked "Med." should always be used.

3. Set the tuning indicator of the signal generator to the frequency desired; then turn the band switch to the letter of the scale on which the frequency appears.

4. Attenuation of the signal is obtained by the multiplier control marked 1, 10, 100, 1000. Set the knob at the point which will give sufficient signal input to the receiver. Complete control of this level from maximum to minimum is then obtained by the variable "attenuator" control located above the "multiplier" control. When the "High" jack is used the multiplier control has no effect on the signal.

5. When adjusting I-F circuits connect a 0.1 mfd. condenser between the antenna lead of the output cable and the grid of the tube in the receiver.

In aligning the R-F circuit of broadcast bands in receivers designed for a standard type aerial, connect a 200

PHILCO SIGNAL GENERATORS

MMFD. CONDENSER between the antenna lead of the signal generator and the antenna terminal of the receiver. In aligning the short wave bands replace this condenser with a 400-OHM CARBON RESISTOR.

When aligning receivers designed for the Philco High Efficiency Aerial, or receivers using a doublet aerial system with a transmission line, connect the output cable of the signal generator directly to the transmission line terminal of the receiver. In aligning receivers of this type the output cable must be connected to the "Mod." and "Gnd." jacks.

AUDIO SIGNAL TEST

1. Turn the "Band Switch" to "Audio".
2. Set power-modulation switch to "Mod on."
3. Insert the output cable pin tips into the "High" and "Gnd." jacks. The other end of the wire in the "High" jack is connected through a .1 mfd. condenser to any section of the audio circuit to be tested, i.e., 2nd det. grid; 1st audio grid or output tube grid.
4. Attenuation of the audio signal is then obtained by the "Attenuator" control. If a weaker audio signal is desired, insert the output pins in the "Med." and "Gnd." jacks. When the "Med." jack is used, the "Multiplier" and "Attenuator" control the audio signal.

DIAL CALIBRATION

In order to calibrate the scales of the dial accurately, the dial indicator must be aligned to track properly with the tuning condenser. To do this proceed as follows: Turn the tuning condenser to the maximum capacity position (plates fully meshed).

With the tuning condenser in this position, loosen the set screws of the indicator collar, being careful not to disturb the setting of the tuning condenser.

Then turn the indicator until the knife-edge pointer covers the horizontal line at the bottom left hand end of the scales.

Tighten set screws in this position.

After the dial indicator is set, each scale of the signal generator is adjusted by the individual compensating condensers, locations of which are shown in the figure. Briefly, the method of calibration is to zero beat the generated signal against signals from accurately controlled broadcast stations or short-wave stations operating on frequencies near the high frequency end of each scale.

SCALE A: Turn modulation switch to "Mod Off" position. Connect the signal generator output lead to the radio receiver antenna terminal. Now, tune the radio receiver accurately to a station on the standard broadcast band, the frequency of which is double that of any frequency between 300 KC. and 360 KC. on Scale A of the signal generator. When the station is tuned, turn the Band Switch knob to

"A" and set the indicator of the signal generator to the frequency mark on Scale A that corresponds to $\frac{1}{2}$ the station frequency.

EXAMPLE

If the station frequency is 600 KC., set the indicator of the signal generator to $\frac{1}{2}$ that frequency, or 300 KC., on Scale "A". With receiver and signal generator set in this manner, adjust the compensator for Scale "A" until a whistle or beat note is heard in the receiver. Adjust the compensator until this whistle (beat note) is eliminated, or is made as low as possible. This is the correct adjustment for Scale "A".

SCALE B: Turn the Band Switch knob to "B". Then tune the radio receiver to a station between 850 KC. and 900 KC. Set the signal generator indicator to the frequency on Scale "B" corresponding to the station. Now, adjust compensator "B" for zero beat as given above for Scale "A".

SCALES C, D, AND E: These scales are adjusted by using the same procedure given for "B". The Band Switch of the signal generator, however, is turned to the letter corresponding to these scales and the radio receiver tuned to some station operating on a frequency corresponding to that shown on the high frequency end of each of these scales. On Scale "C" the frequency should be between 3.0 MC. and 3.6 MC. On Scale "D" the frequency should be between 10 MC. and 12 MC., and on Scale "E", between 28 MC. and 36 MC.

LOCATION OF COMPENSATORS

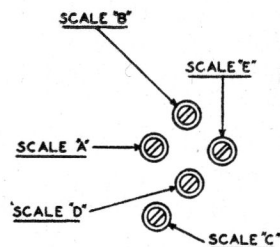

REPLACING TUBES

Remove the screws holding the front panel to the case and lift panel straight out. The tubes will be found in sockets mounted on small sub-bases. The rectifier (6X5G) is located at the top, and the 6J5G modulation generator and 6J7G oscillator tubes are at the bottom of the panel.

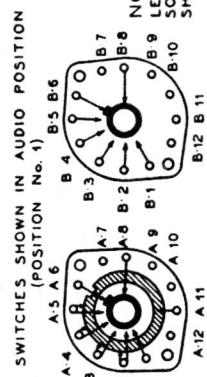
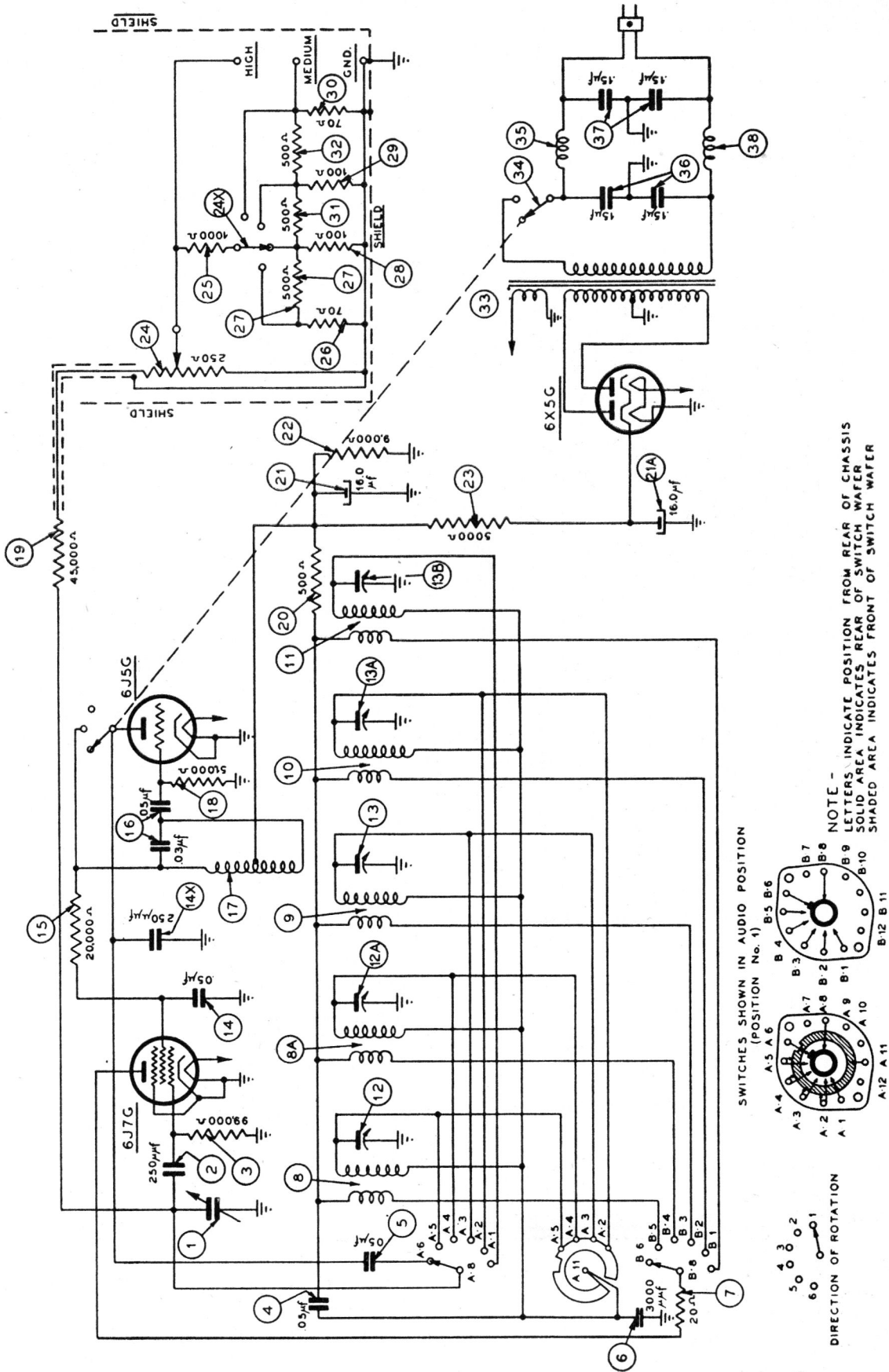

PHILCO MODEL 077 SIGNAL GENERATOR
(SCHEMATIC DIAGRAM)

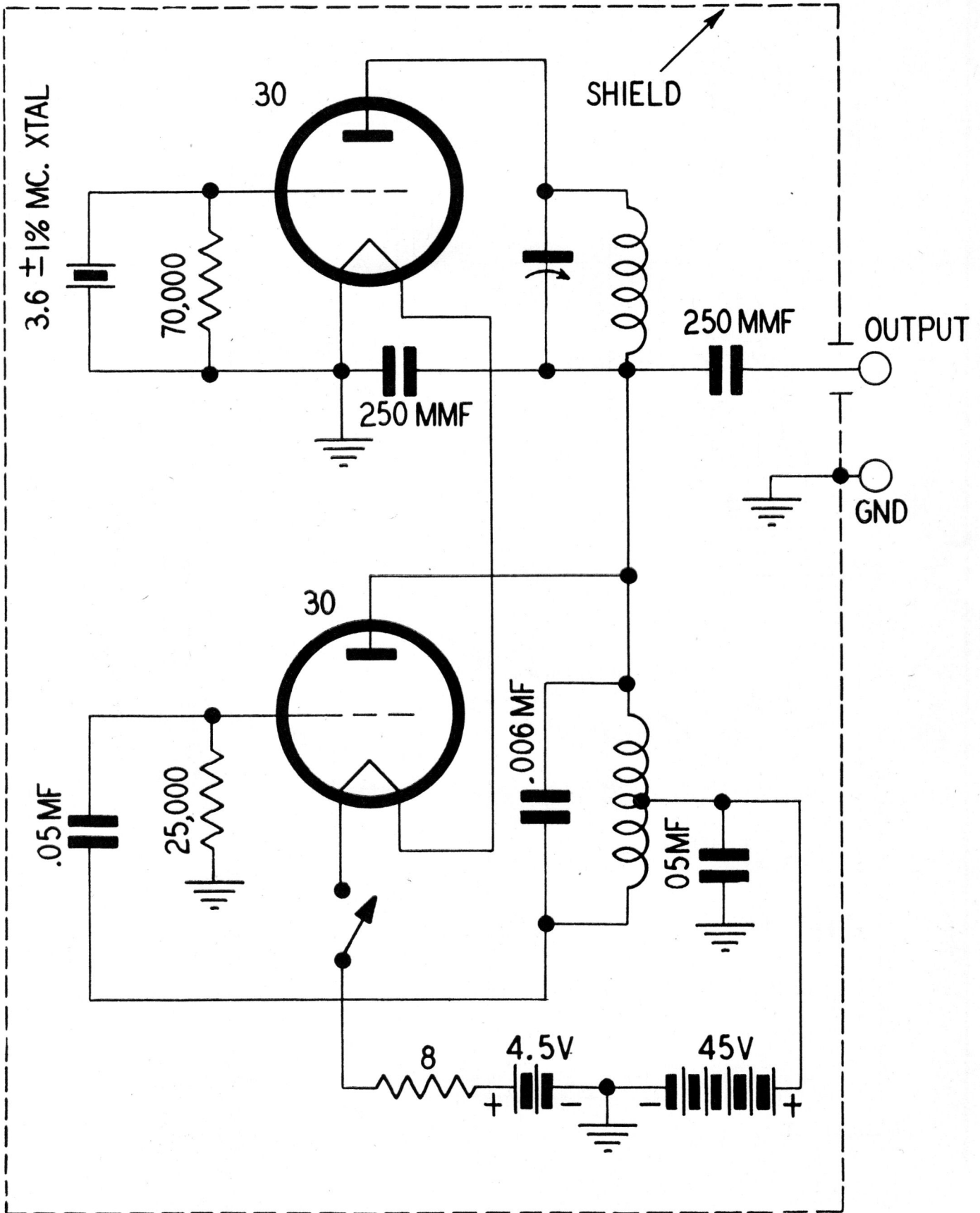

PHILCO MODEL 091 SIGNAL GENERATOR (SCHEMATIC DIAGRAM)

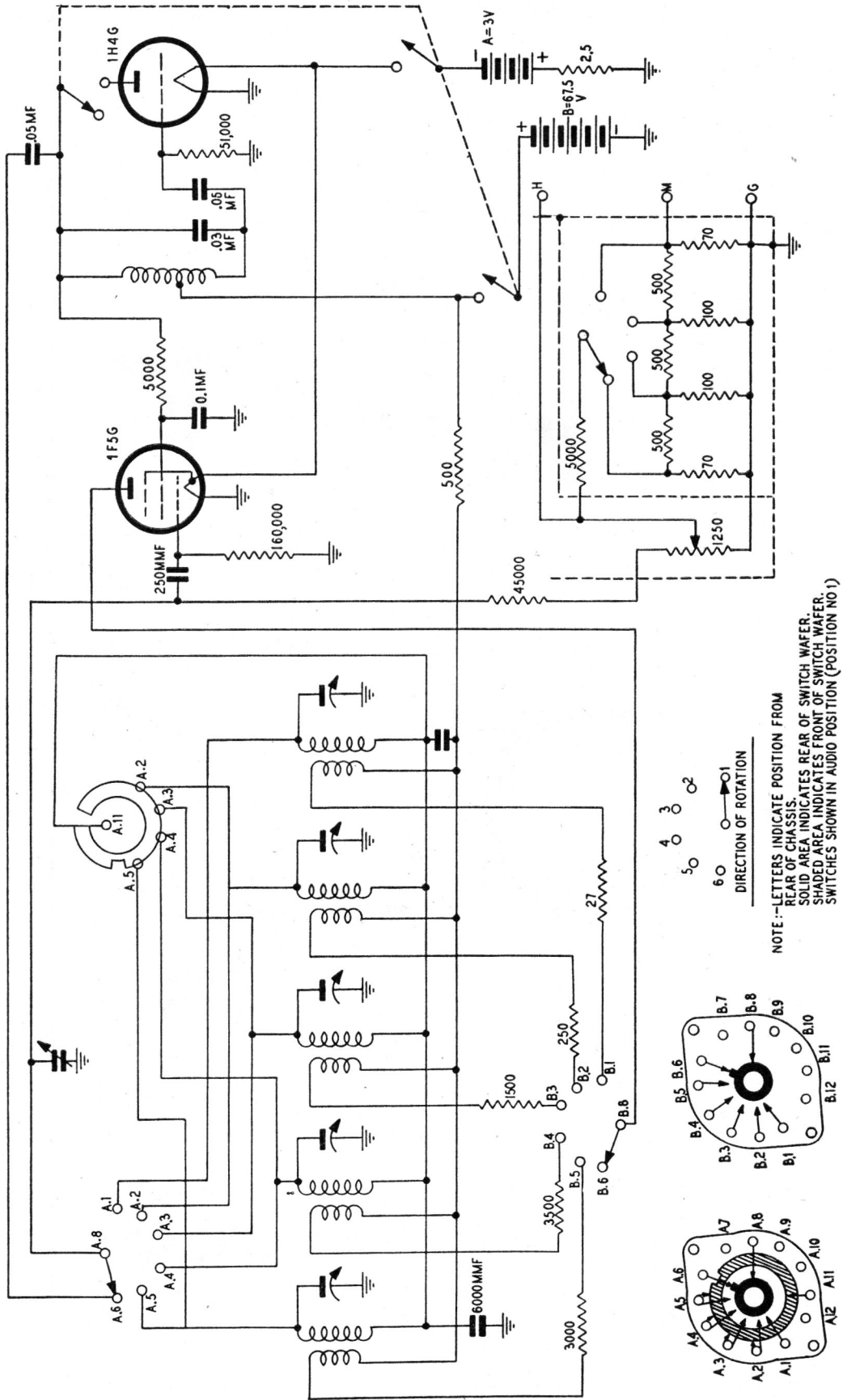

PHILCO MODEL 177 SIGNAL GENERATOR
(SCHEMATIC DIAGRAM)

Section III

PHILCO AUDIO SIGNAL GENERATORS

Philco Model 044

Philco Model 055

PHILCO AUDIO SIGNAL GENERATORS

PHILCO MODEL 044 AUDIO SIGNAL GENERATOR

PHILCO MODEL 044 AUDIO SIGNAL GENERATOR is designed to meet the many service problems requiring an audio frequency source of voltage, such as testing speaker units for rattles and buzzes; adjusting 10 KC. audio filter circuits; locating and isolating trouble in audio amplifier stages; testing overall operation of a radio receiver; checking radio cabinets for loose sections which vibrate at certain frequencies, and making audio frequency comparison tests before and after servicing.

DESCRIPTION

The generator is designed to operate from 115-volt 50 or 60-cycle A-C power supply and provide at the output jacks marked "A.F." and "R.F.", continuously variable audio frequencies in the range from 60 to 11,000 cycles per second or a fixed R-F signal of 580 KC. modulated by the variable audio frequency circuit. The audio signal of this generator is produced by the beat or difference frequency of two R-F oscillators. Two Philco 6Y7G tubes are used for this purpose. One tube acts as a variable oscillator and detector and the other a fixed oscillator and output tube. A 6X5G tube is used in the power circuit for supplying D-C voltages for operation of the instrument.

OPERATION

Under separate headings are listed the routine methods for using the audio signal generator in servicing a receiver. These procedures include centering speaker cones; testing and localizing trouble in the audio circuits; adjusting 10 KC. audio filter, and overall test of a radio receiver.

To operate the generator, insert the power cable female plug into the socket on the side of the instrument and connect the male end into a 115-volt, 50 or 60-cycle power supply. The power switch located at the lower right hand corner of the case is then turned to "on". In order to assure greater stability of operation, the generator should be allowed to heat for at least 10 minutes and then calibrated using the procedure given under "Dial Calibration." This takes but a few minutes and will assure accurate reading of the dial scale.

AUDIO SIGNAL CONNECTIONS

If an audio test is desired, plug the output cable into the jack marked "A.F." Connect the output cable shield wire into the "GND." jack. The output circuit at this jack delivers an audio signal in the range from 5 to 10 volts, depending on the impedance of the applied load and the frequency used. Attenuation of the output is obtained by the "output control".

R-F SIGNAL CONNECTIONS

For an overall check of a receiver the jack marked "R.F." supplies a 580 KC. R-F signal modulated by the variable audio signal. The output control has no effect upon the signal at this jack. With the output lead connected into one of the above jacks any of the following tests may be made.

CENTERING SPEAKER CONES

Speaker cones may be centered using a strong signal of a low frequency by setting the pointer half way between "0" and "100" on the dial scale of the signal generator. Apply the signal to the antenna when using the 580 KC. R-F signal or the first audio grid when using the "audio" signal.

OVERALL TEST OF A RECEIVER

The 580 KC. R-F signal is used in checking a receiver for overall tone quality and in locating loose parts in the receiver or cabinet that vibrate at certain frequencies. To use the 580 KC. signal insert the antenna and ground lead of the generator into the "R.F." and "GND." jacks. Connect the other end of the leads to the "Ant." and "Gnd." terminals of the radio chassis. Tune radio dial to 580 KC.

Now slowly vary the signal generator indicator over the entire scale and listen closely to the speaker response. If the receiver distorts or a rattle or buzz develops at some frequency in the audio range, the cause of the distortion or buzz can be readily detected and located by leaving the indicator at that frequency.

TESTING AND LOCALIZING TROUBLES IN AUDIO AMPLIFIERS

The audio signal generator is most helpful in tracing and localizing trouble or determining the operating condition of audio amplifiers. The output of the "A.F." jack is used for this purpose. Insert the output lead into the "A.F." and "GND." jacks and connect the other end on which the clips are attached to the grid of the output tube and chassis respectively.

By transferring the clip from the grid of each tube beginning with the output tube and continuing to the detector tube each stage of the amplifier can be individually tested for audio response. This method of servicing gives a rapid check of the audio amplifier or localizes the trouble if the audio circuit is inoperative.

By varying the indicator of the audio signal generator a complete check of any of these parts or stages over the entire audio frequency range is obtained.

PHILCO AUDIO SIGNAL GENERATORS

ADJUSTING 10 KC. AUDIO FILTERS

The audio signal generator is useful for adjusting audio filters which are usually located in the plate circuit of the detector tube or first audio tube, such as the 10 KC. audio filter in the Philco Model 680 and 37-690 receivers. To adjust the audio filter circuit, connect the output lead clip to the high side of the volume control. Then turn the dial of the signal generator to 10,000 cycles. Leave the dial at this point. Now adjust the audio filter compensator of the receiver for minimum output.

CALIBRATION OF DIAL

To align the oscillator circuit of the generator with the dial scale, proceed as follows:

CHECKING POINTER

Rotate the dial scale indicator in a counter-clockwise direction (towards the low frequency end) until the pointer stops. When this position is reached the indicator should be on the zero line. If the pointer is not on the zero line, loosen the set screws on the hub and adjust the pointer to cover the zero line.

ADJUSTING FOR ZERO BEAT

1. There are two methods of adjusting the oscillator for zero beat. One is to take the output of the "A.F."

jack and feed it into the input circuit of an audio amplifier or the audio circuit of a radio receiver. The other method is to take the output of the "R.F." jack and feed it into the antenna of a radio receiver, tuning the receiver to 580 KC.

2. Tune the 044 indicator and listen for an audio signal in the receiver. This signal will change in pitch as the indicator is rotated, and should reach zero frequency (no beat note) when the indicator is at the "zero line." If a note is still heard in this position take the following steps:

Leave the pointer on the zero line, then insert a screw driver into the compensator screw hole marked "zero adj." (see cut). Turn the screw counter-clockwise until the signal goes down to zero frequency, and then starts to increase in frequency. When this point is reached, turn the screw slowly clockwise in the reverse direction. Note that the signal goes down in frequency again. Continue turning the screw until the signal stops. This is the correct position for the zero frequency adjustment. If this adjustment has been carefully made, a low frequency note will be heard as soon as the generator indicator leaves the zero line. This adjustment must be made whenever an exact value of frequency is needed, and will have to be reset slightly as the instrument heats up during a long process of operation.

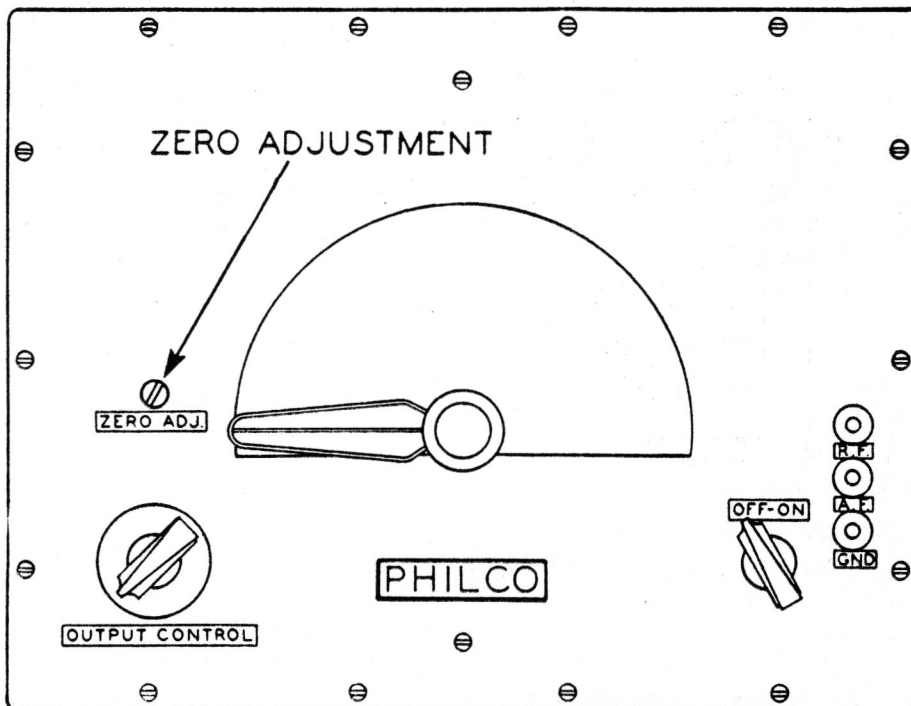

FRONT PANEL OF AUDIO SIGNAL GENERATOR

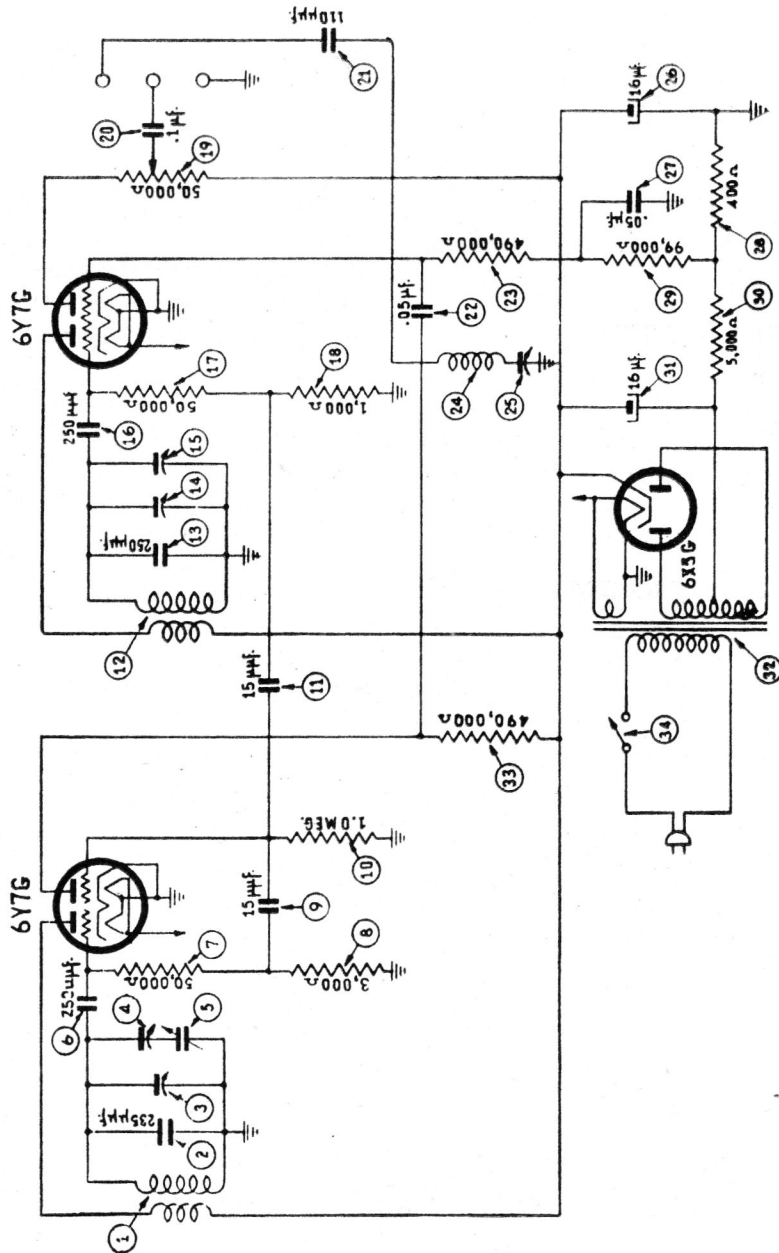

PHILCO MODEL 044 AUDIO SIGNAL GENERATOR (SCHEMATIC DIAGRAM)

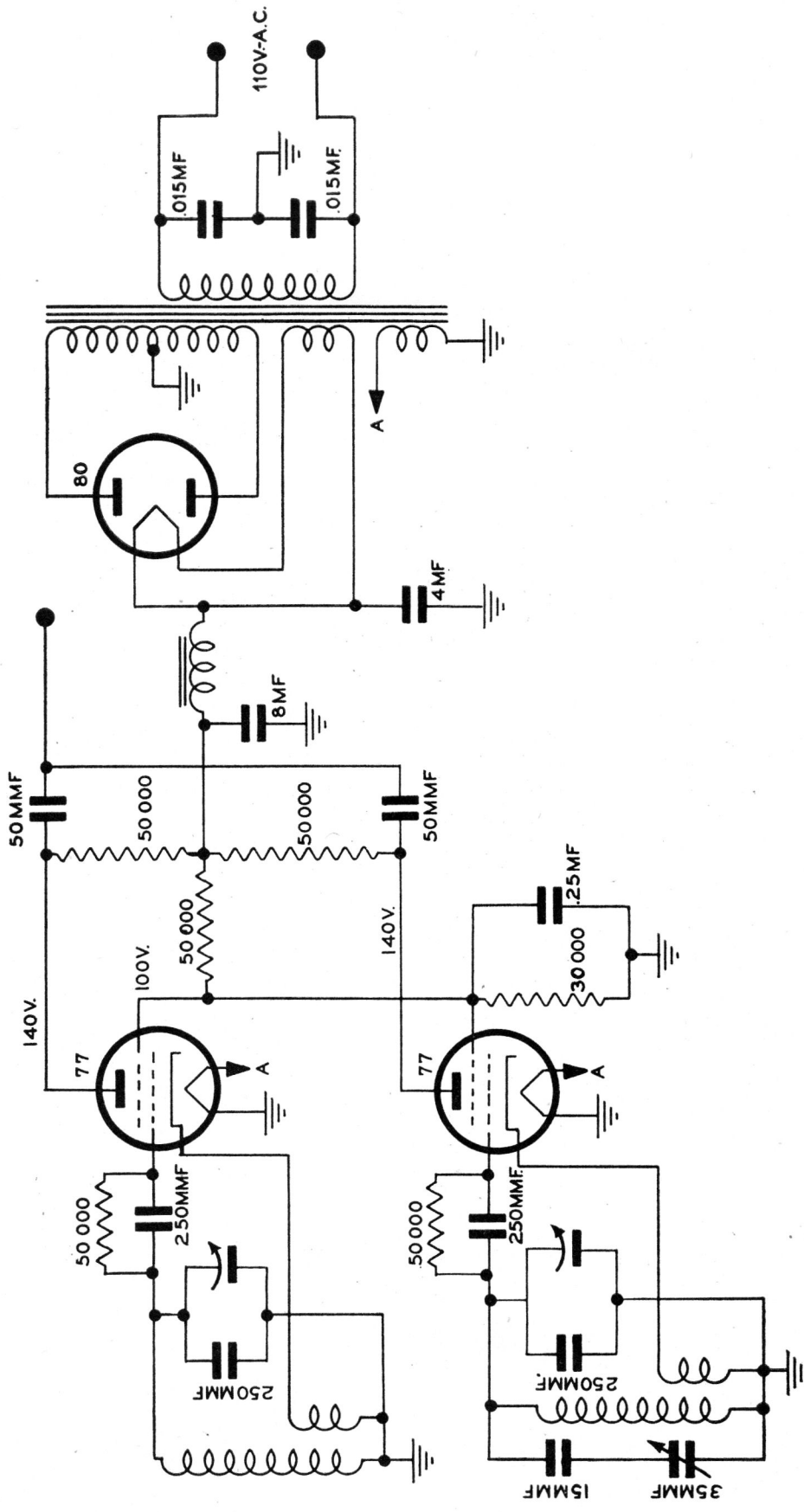

PHILCO MODEL 655 AUDIO SIGNAL GENERATOR
(SCHEMATIC DIAGRAM)

Section IV

PHILCO TUBE TESTERS

Philco Model 033

Philco Model 050

Philco Model 066

Section V

PHILCO MISCELLANEOUS TESTING EQUIPMENT

Philco Model 010 Condenser Tester

Philco Model 013 Vibrator Tester

Philco Model 014 Wireless Station Setter

Philco Model 015 Battery Tester

Philco Model 022 Cathode-Ray Oscilloscope

Philco Model 029 Appliance Tester

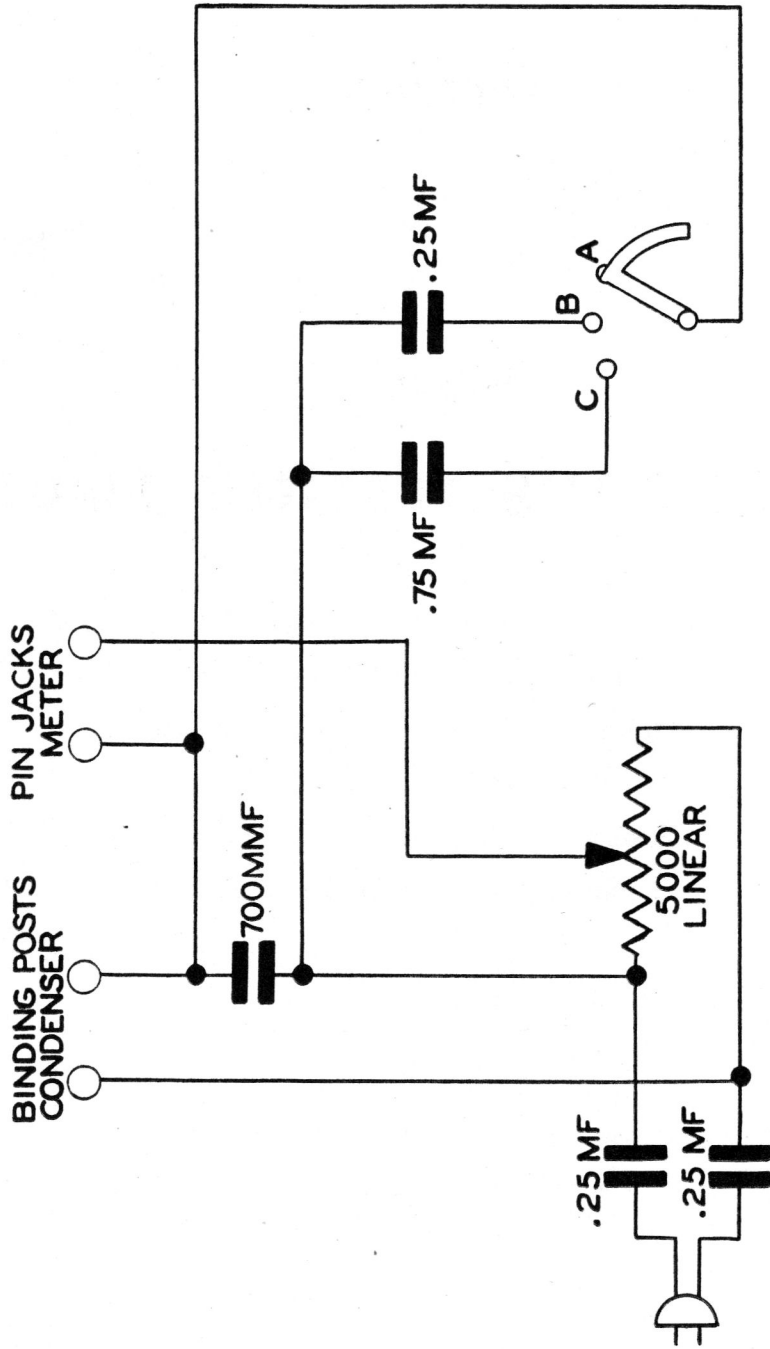

PHILCO MODEL 010 CONDENSER TESTER
(SCHEMATIC DIAGRAM)

SOCKETS SHOWN FROM
BOTTOM VIEW

PRONGS INDICATED TO BE
FILLED WITH SOLDER

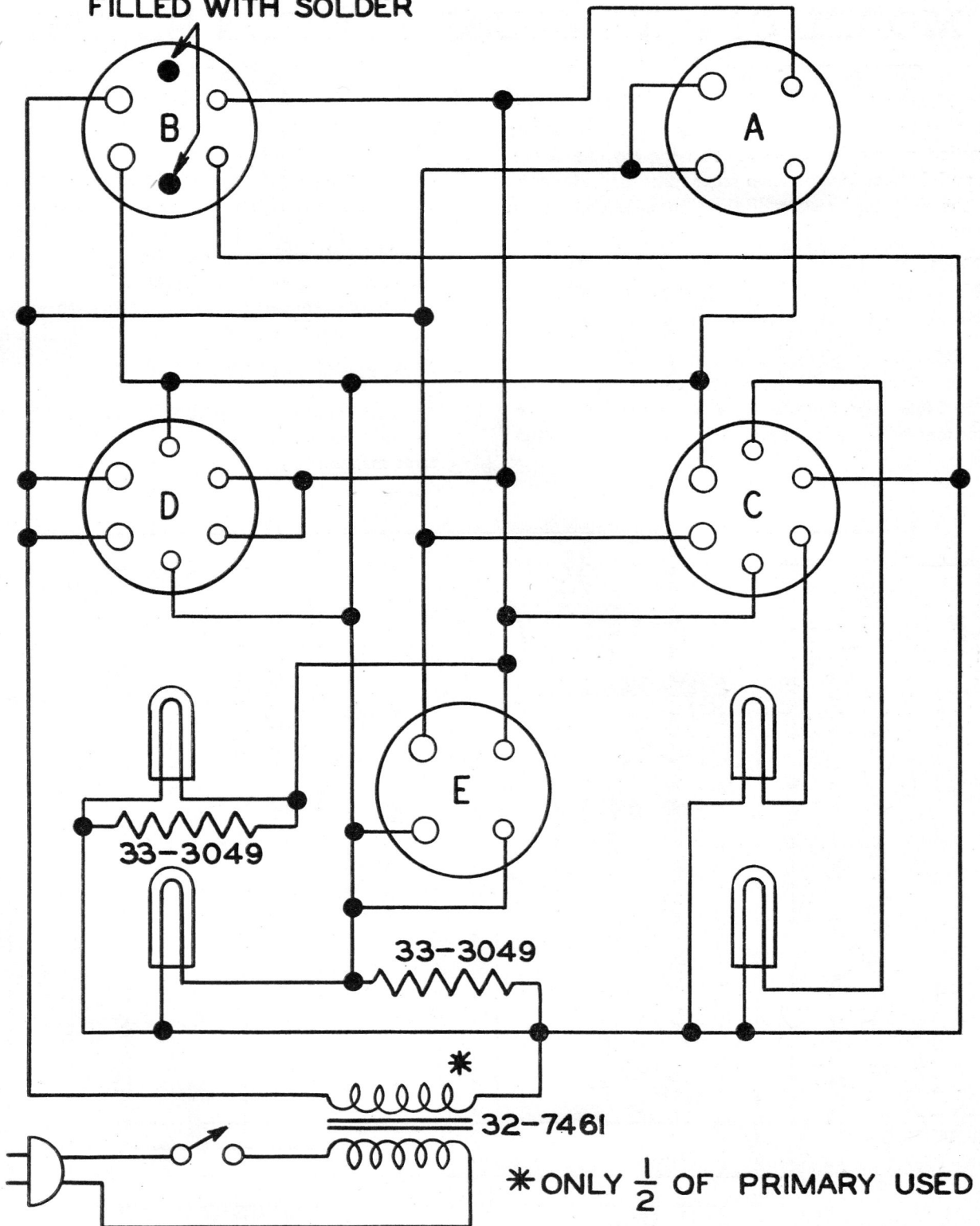

* ONLY $\frac{1}{2}$ OF PRIMARY USED

PHILCO MODEL 013 VIBRATOR TESTER (SCHEMATIC DIAGRAM)

PHILCO MODEL 014 WIRELESS STATION SETTER

CALIBRATING INSTRUCTIONS

The Model 014 Station Setter is designed to take the place of standard broadcasting stations when adjusting automatic tuning radio receivers. Pressing any one of the eight push-buttons in the station setter turns the instrument on. The frequency ranges of these push-buttons are as follows:

- No. 1, 2 and 3 540 to 1000 KC.
- No. 4 and 5 650 to 1100 KC.
- No. 6, 7 and 8 800 to 1600 KC.

NOTE: Push-button No. 1 is at the left.

To accurately adjust the station setter, it is recommended that the Model 027 Vacuum Tube Voltmeter be used in conjunction with a radio receiver of the eight-push-button type.

First set up the eight push-buttons on the radio using the vacuum tube voltmeter connected to the AVC circuit in the usual manner.

1. Insert tabs for stations desired on the station setter.
2. Leaving the vacuum tube voltmeter connected to the radio, place the station setter close to the loop aerial in the radio and press push-button No. 1. (15 minutes should be allowed for the station setter to reach maximum operating temperature.)
3. Adjust the compensator in the station setter opposite No. 1 push-button until the 400-cycle signal is heard. This signal will usually override the station program and will increase the vacuum tube voltmeter reading beyond the maximum produced by the station alone.
4. Adjust compensators for remaining push-buttons in same manner.

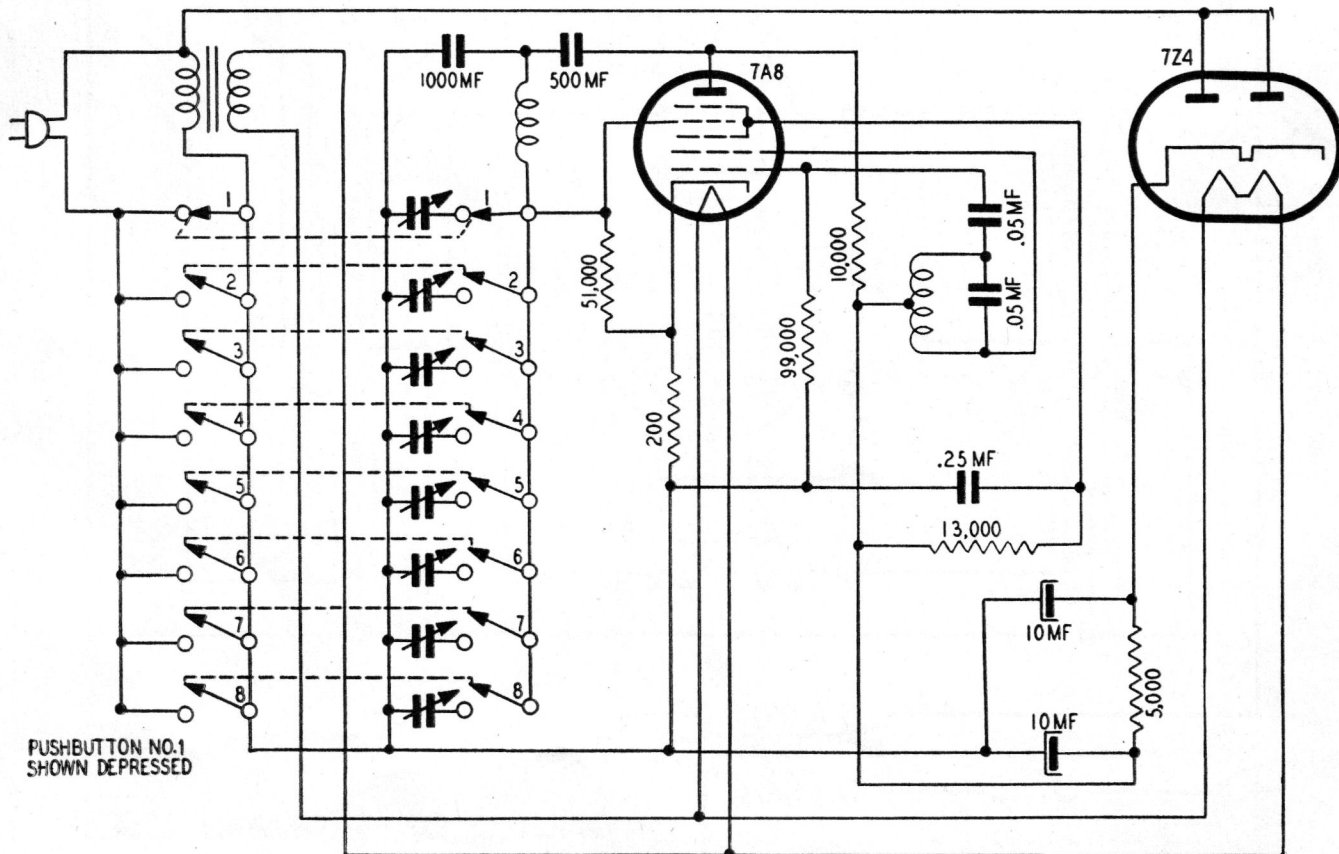

PHILCO MODEL 014 WIRELESS STATION SETTER (SCHEMATIC DIAGRAM)

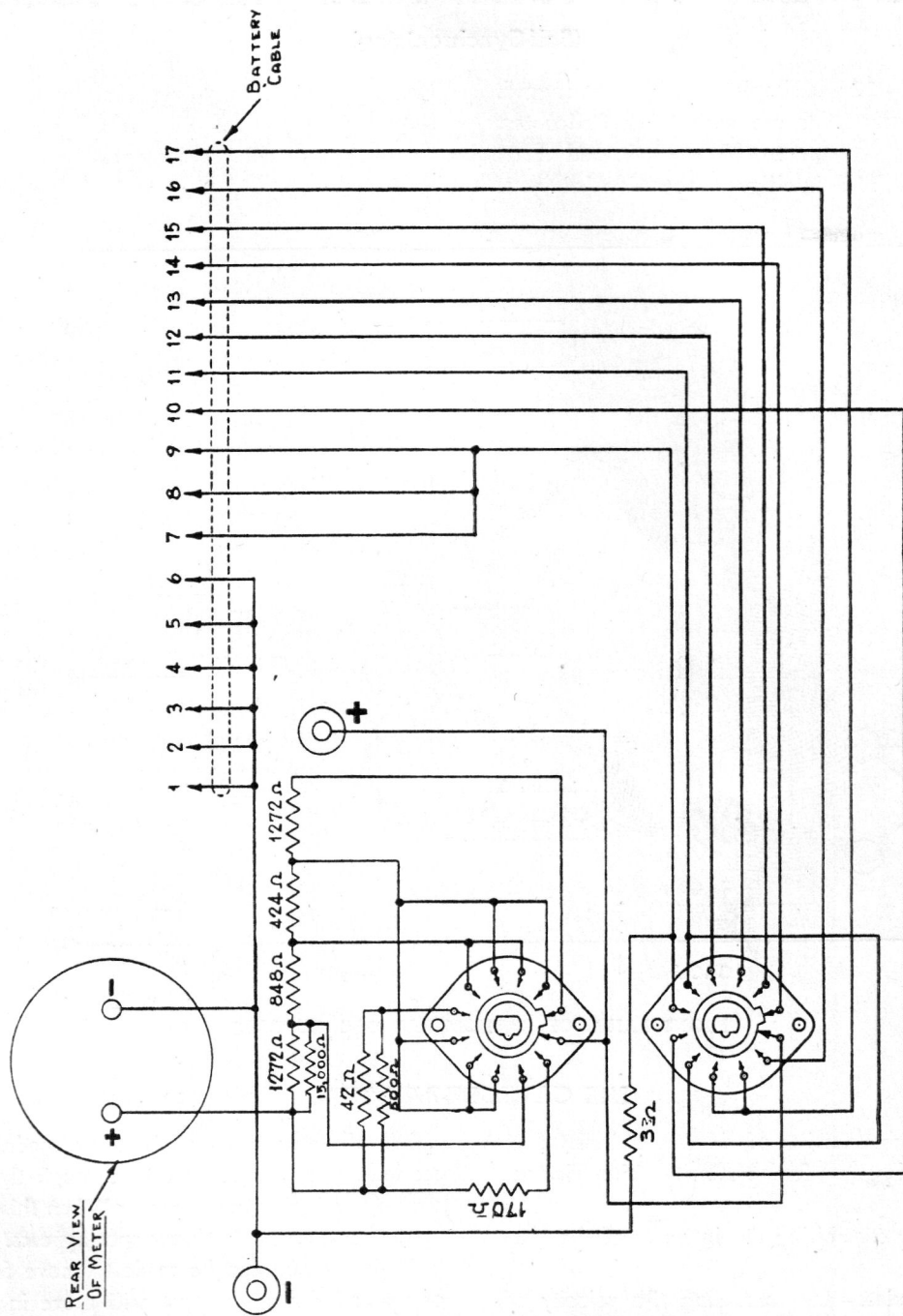

PHILCO MODEL 015 BATTERY TESTER
(SCHEMATIC DIAGRAM)

PHILCO MODEL 022 CATHODE-RAY OSCILLOSCOPE

(Self-Synchronizing)

The Philco Model 022 is a simple, portable, and rugged, yet complete oscilloscope for use with other Philco test equipment for radio receiver trouble analysis and many other applications. The intelligent operation of your

Philco Model 022 involves some knowledge of the fundamental principles of the cathode-ray tube which forms the nucleus of the oscilloscope.

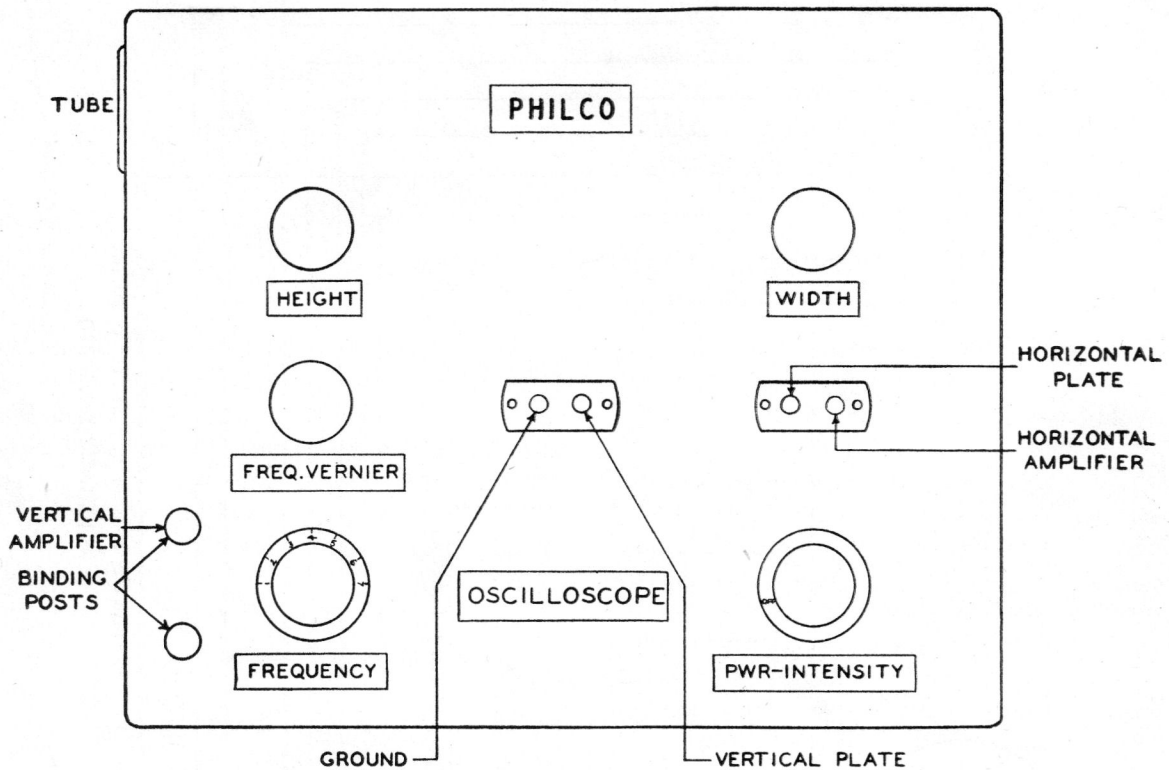

FRONT PANEL OF CATHODE-RAY OSCILLOSCOPE

THE CATHODE-RAY TUBE

The cathode-ray tube consists of six essential parts:

- (1) The electron gun—for producing the electron stream;
- (2) the grid—for controlling the intensity of the electron stream;
- (3) accelerating plate—for increasing the velocity of the electron stream and so producing the image;
- (4) focusing grid—for focusing the electrons upon the screen;
- (5) the deflecting plates—for deflecting the electron stream to create the desired image pattern; and
- (6) the screen—to produce a visual image dependent upon the position of the stream.

The electrons given off by the cathode are focused and accelerated, so that they flow through the tube in a thin stream at a high rate of speed. When this stream impinges upon the screen, a luminous spot appears.

If this stream can be made to move from side to side or up and down, the spot will move in a corresponding manner. If this movement is fast enough and recurrent, the spot will appear as a steady pattern.

Since the electron beam actually consists of electrons, and therefore has a negative electrostatic potential, movement of the beam is easily accomplished by means of electrostatic forces. A positive potential in the vicinity of the beam will cause a movement toward the external voltage,

PHILCO MISCELLANEOUS TESTING EQUIPMENT

and a negative potential will cause a movement in the opposite direction. The degree of movement is proportional to the voltage which causes it.

a readable deflection of the electron beam. The Philco Model 022 contains two amplifiers, one each for the vertical and horizontal plates. The deflection sensitivity

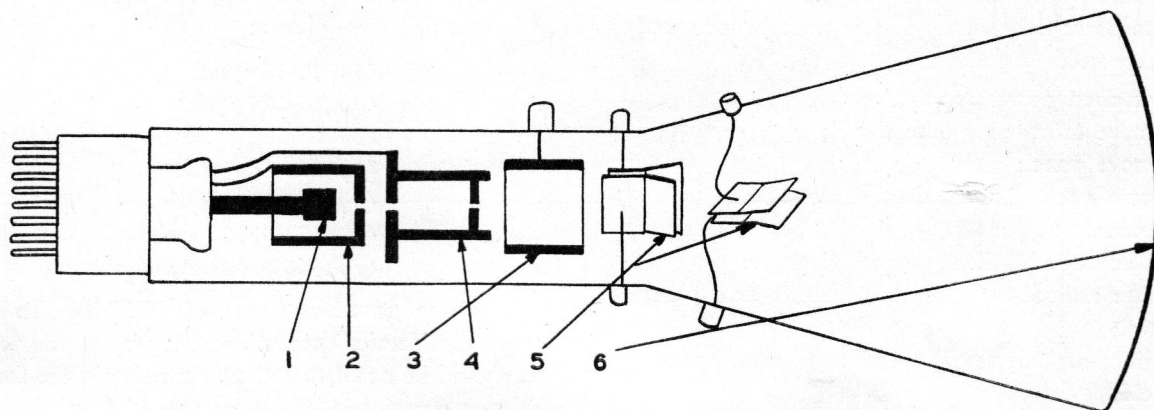

LOCATIONS OF CATHODE-RAY TUBE ELEMENTS

Cathode-ray tubes of the electrostatic deflection type contain two pairs of deflecting plates. These pairs are located with their axes perpendicular and in such a position that the axis of one pair is horizontal and that of the other is vertical. These two pairs of plates are used to produce horizontal and vertical electron beam deflection.

If a sine wave is applied to the vertical deflecting plates, the electron beam will be deflected up and down at the same frequency as the impressed wave, and a vertical straight line trace will be produced. This image would be useful only in determining the peak value of the voltage under consideration. However, if the beam is now moved uniformly from left to right, the impressed wave will appear in its true form.

Since the cathode-ray tube has definite limits, and it is impossible to move the beam indefinitely in any one direction, in practice, the beam is moved from left to right far enough to trace one cycle, then returned to its starting point to repeat the process. In this manner, one cycle of the external wave appears stationary on the screen.

This timing wave is produced by a "sawtooth" generator, the output of which is connected to the horizontal deflecting plates. The output of this generator increases linearly to a certain point, then drops quickly to zero and the cycle repeats. This generator circuit, consisting of a gas filled triode (884) and suitable associated circuits, provides a continuously variable frequency, permitting the study of voltages at any frequency up to the limit of the generator.

The examination of voltages of small magnitude would be impossible if amplification were not provided to produce

of the instrument on either set of plates is approximately 4.0 volts per inch of deflection with maximum amplification. With the amplifiers out of the circuit, the deflection sensitivity is 80 volts per inch. These amplifiers have essentially constant output up to 100 kilocycles. The gain of the vertical and horizontal amplifiers is regulated by the "Height" and "Width" controls respectively.

CONTROLS

The operator should become thoroughly familiar with the controls of the Model 022 before proceeding with any adjustments. Observe the illustration carefully for location of the controls. These are (left to right) top row: Amplifier gain controls—(1) Height, (2) Width; middle row—(3) Frequency vernier, (4) Terminal panel number 1, (5) Terminal panel number 2; bottom row—(6) Frequency, (7) Power-Intensity.

The vertical and ground posts in the lower left hand corner connect to the vertical amplifier and ground.

The terminal panel connections are (from left to right): ground, vertical plate (without amplifier), horizontal plate, and horizontal amplifier.

Focus adjustment is by means of a screw on the back of the case.

PRELIMINARY ADJUSTMENTS

Insert the power cord in 115-volt, 50-60 cycle outlet. Turn the Power-Intensity Switch on. Allow the tubes to warm up for about one minute. Retard "Height" and "Width" controls completely (counter-clockwise). Ad-

PHILCO MISCELLANEOUS TESTING EQUIPMENT

vance "Power-Intensity" control until a small spot is visible on the screen. Advance "Frequency Vernier" control about half its range. Adjust "Focus" control (on back of instrument) until spot is smallest possible. Advance "Width" control sufficiently to cause the straight line horizontal trace just to cover the screen. If this trace is not exactly horizontal, proceed as follows:

- (1) Disconnect power supply;
- (2) Remove cathode-ray tube shield;
- (3) Remove panel;
- (4) Loosen screws in cathode-ray tube socket;
- (5) Reconnect power supply, allow tubes to warm up and advance "Width" control as above;
- (6) Rotate cathode-ray tube until trace is exactly horizontal;
- (7) Tighten socket screws, replace cover panel and tube shield;

The above adjustments need not be made more than once for each tube.

GENERAL PRECAUTIONS

- (1) Do not allow a bright spot or straight line trace to remain on the screen over ten seconds.
- (2) Always retard Power-Intensity control except when actually making observations.
- (3) Always use as little intensity as possible to give a readable image.
- (4) No external voltage of a higher potential than five hundred (500) volts should be connected to any of the binding posts or terminals of this instrument.
- (5) Connect a ground lead to the binding post marked "Ground" in the lower left hand corner of the oscilloscope panel.

WAVE ANALYSIS

For analysis of frequencies up to 100 KC., proceed as follows:

- (1) Turn "Power-Intensity" switch on.
- (2) Connect the terminals of the voltage source under observation to the binding post at the bottom left corner of the panel. The low side of the circuit should be connected to the "Ground" post and the high side to the "Vertical" post.
- (3) Advance the intensity control just enough to provide a readable image.
- (4) Advance the "Height" and "Width" controls until the image is of a convenient size and in proper proportion.

- (5) Adjust the frequency of the sweep circuit, by means of the "Frequency" and "Frequency Vernier" controls until the desired number of cycles of the observed wave appear on the screen. The range available at each of the positions of the "Frequency" control is as follows:

- (1) 15-50 cycles
- (2) 35-120 cycles
- (3) 80-290 cycles
- (4) 220-840 cycles
- (5) 600-2100 cycles
- (6) 1250-5000 cycles
- (7) 3600-15,000 cycles

The sweep generator is turned "Off" by turning the "Frequency Vernier" control all the way to the left.

It should be noted that at no time should the frequency of the sweep circuit be higher than that of the voltage under observation, but may be lower. For example: If the external voltage has a frequency of 400 cycles, the sweep frequency may be 400, 200, 133, 100, 80. These frequencies will give a pattern on the screen of 1, 2, 3, 4, and 5 cycles respectively.

In this manner a rapid and accurate check may be made to determine the presence of distortion in any A-C signal—for example, the output of an audio amplifier. The observed trace from the output should be an exact copy of the input, where a sine wave is used. The Philco Model 044 Audio Signal Generator is especially recommended for such service, since its wave form is essentially a pure sine wave at all frequencies. If the output wave form is not a sine wave but is symmetrical about the zero axis and contains peaks or irregularities, it is evident that odd-order distortion exists (3rd, 5th, 7th, 9th, etc., harmonics of the fundamental). If the wave is not symmetrical about the zero axis, even-order distortion is present (2nd, 4th, 6th, 8th, etc., harmonics).

FREQUENCIES ABOVE 100 KILOCYCLES

For measurements of voltages at frequencies beyond the range of the self-contained sweep circuit, access is provided to the vertical and horizontal deflecting plates and amplifiers through the terminal panels as described under Controls.

By use of these terminals, inspection of voltages at very high frequencies may be made, either by the harmonic sweep method or by the introduction to the horizontal deflecting plates of a sawtooth sweep circuit of the proper frequency.

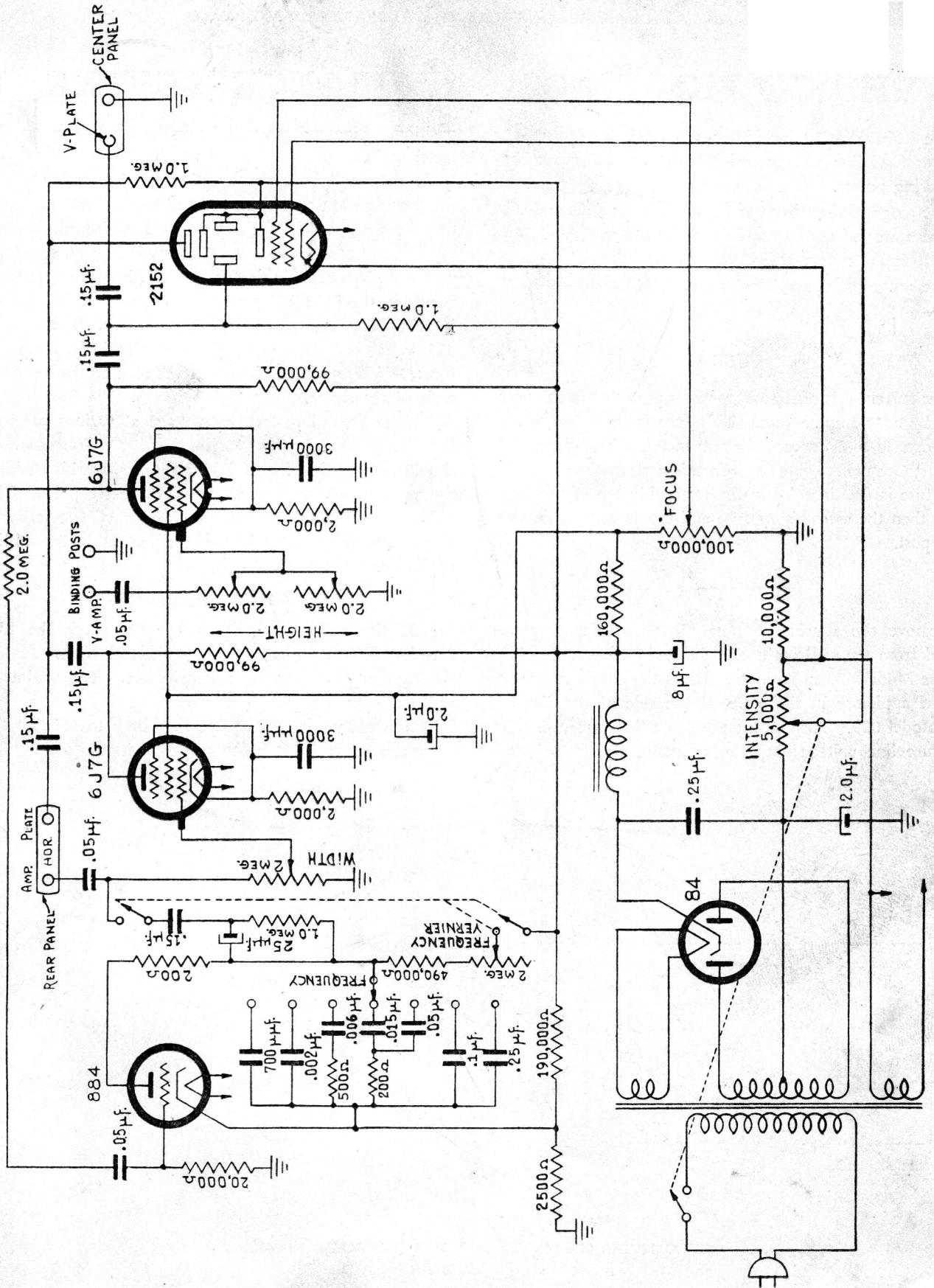

PHILCO MODEL 022 CATHODE-RAY OSCILLOSCOPE (SCHEMATIC DIAGRAM)

PHILCO MISCELLANEOUS TESTING EQUIPMENT

PHILCO MODEL 029 APPLIANCE TESTER

The MODEL 029 includes a voltmeter for measuring A-C or D-C line voltage and a two-range wattmeter for measuring power.

The range of the voltmeter is: 0-250 volts A.C. or D.C.

There are red marks on the scale at 110 volts and 220 volts to indicate normal line voltages.

The ranges of the wattmeter are: 0-375 watts—0-1500 watts.

FUSE

The current coil of the wattmeter is protected from overload by a 15-ampere fuse. This fuse is in the extractor fuse post located between the two meters. To replace the fuse remove the bakelite screw in this post, marked "Fuse". The fuse is first inserted in the removable cap of the fuse post, then the assembly of fuse and cap is inserted in the fuse post.

OPERATION

Remove the attachment plug of the appliance to be tested from the wall outlet and insert the attachment plug of the Model 029 in its place. Insert the attachment plug of the appliance in the outlet at the side of the case of the Model 029. Turn on the power on the appliance. To measure line voltage snap the voltmeter switch to "IN"

position. Line voltage will be indicated directly on the meter scale.

To measure power consumption of the appliance the wattmeter switch should be snapped to the "HIGH" position before pressing the "Press to Read" push button. Press the push button and read the power in watts directly on the 1500-watt scale of the meter. Keep the wattmeter switch in the "HIGH" position (1500-watt scale) for all large appliances. If the reading obtained is less than 375 watts the wattmeter range switch should be moved to the "LOW" position and the wattage read on the 375-watt scale of the meter.

If it is desired to test for voltage at various parts of the circuit in the appliance under test, the voltmeter switch should be moved to the "OUT" position. In this position the voltmeter is connected to the voltmeter jacks. The voltmeter can then be used with a pair of test leads to check continuity through the component parts of the appliance.

MAINTENANCE

If the wattmeter fails to operate, check the fuse mentioned in a preceding paragraph, and if this fuse is defective replace with a 15-ampere one. The wattmeter will not operate if this fuse is open.

If the voltmeter fails to operate, check to see that the voltmeter switch is set in the proper position.

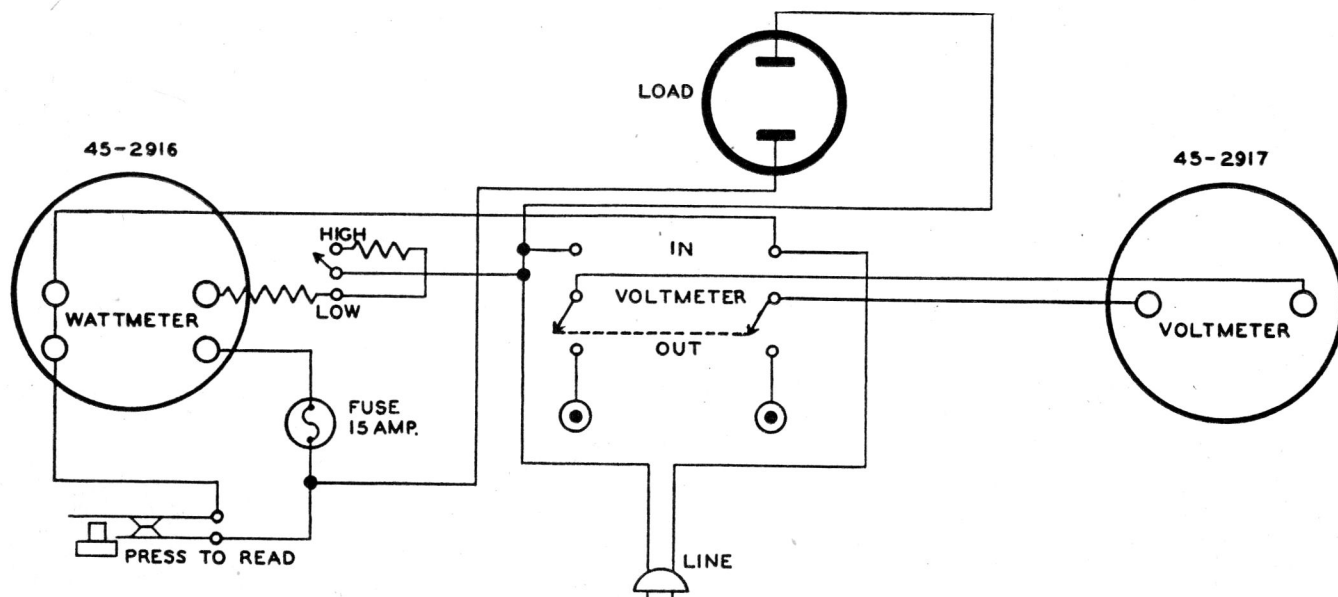

PHILCO MODEL 029 APPLIANCE TESTER (SCHEMATIC DIAGRAM)