

# PHILCO . . . . . Models 37-10 and 37-11



**FOR MEMBERS OF  
RADIO MANUFACTURERS SERVICE  
A PHILCO SERVICE PLAN**

**SERVICE BULLETIN  
No. 268**

## Models 37-10 and 37-11 — Code 121

### Electrical Specifications

**TYPE CIRCUIT:** Superheterodyne, with Automatic (Dial) Tuning, and Magnetic Tuning control on the broadcast range.

Both receivers use a push-pull pentode audio output circuit. The 37-11 receiver however, uses a 6J5G, second detector and 6K5G 1st audio tube.

**DIAL MECHANISM:** Philco Automatic Dial Tuning System.

**POWER SUPPLY:**

Voltage	Frequency Cycles	Consumption	
		37-10	37-11
115	50 to 60	120 watts	125 watts
115	25 to 40	125 watts	130 watts

**INTERMEDIATE FREQUENCY:** 470 K. C.

**UNDISTORTED OUTPUT:** 37-10, 5 watts. 37-11, 7 watts.

**PHILCO TUBES USED:** 37-10—Nine. Two 6K7G; one 6A8G; one 6N7G; one 6H6G; one 6Q7G; two 6F6G, and one 5Y4G. 37-11—Ten. Two 6K7G; one 6A8G; one 6N7G; one 6H6G; one 6K5G; one 6J5G; two 6F6G, and one 5Y4G.

**TUNING RANGES:** Three.

Range 1—530 to 1720 K. C.

Range 2—2.3 to 7.4 M. C.

Range 3—7.35 to 22 M. C.

**TONE CONTROL:** 37-10—3 Positions. 37-11—4 Positions.

**SPEAKER:** H-30.

### Aerial Connections

To obtain the full advantage of the sensitivity of this receiver, the Philco High Efficiency Aerial supplied with the receiver must be used. The connections for the aerial are as follows:

The red and black leads of the High-Efficiency Aerial "transmission line" are connected to terminals 1 and 2 respectively, of the terminal panel provided on the rear of the chassis. Connect the jumper on the terminal panel across terminals 3 and 4.

If a temporary aerial is used, the jumper should be across terminals 2 and 3. The aerial connects to terminal 1 and the ground lead to terminal 3. A good ground connection is desirable in all installations.

### Dial Calibration

In order to adjust this receiver correctly the dial must be aligned to track properly with the tuning condenser. To do this proceed as follows:

- Loosen the shaft coupling set screws. Then turn the tuning condenser fully closed and the dial to the first index line. Now tighten the shaft coupling set screws, and rotate the dial until the 520 K.C. mark is midway between the index line and the glowing beam indicator.

- With condenser in this position loosen the set screws of the shaft coupling on the tuning condenser.

- Then turn the tuning dial until the glowing beam indicator is centered on the index line.

**NOTE:** Be careful when turning the dial that the position of the tuning condenser is not disturbed.

- Now tighten the shaft coupling set screws.

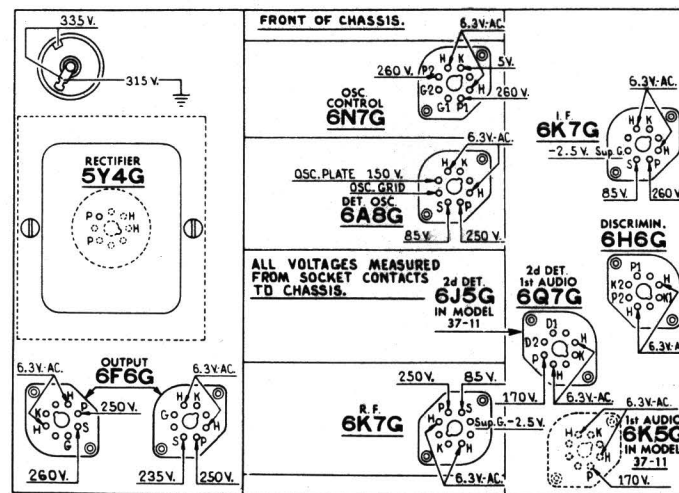

**Fig. 1. Socket Voltages 37-10-11  
Underside of Chassis View**

The voltages indicated by arrows were measured with a Philco 025 Circuit Tester which contains a voltmeter having a resistance of 1000 ohms per volt. Volume Control at minimum, range switch in broadcast position, line voltage 115 A. C.

### NOTE

Models 37-10 and 37-11 are similar in circuit design, with the exception that the 6Q7G tube, 2nd Det. 1st Audio in the 37-10 is replaced with a 6J5G as a diode detector and a 6K5G tube for 1st audio stage in the Model 37-11. The schematic diagram Fig. 3 shows the complete circuit of the 37-11 receiver, also the 6Q7G, 2nd Det. 1st Audio circuit of the 37-10. The parts of these two chassis are the same with the exception of condenser (81A) in the tone control circuit and the tone controls. In Model 37-10 the condenser is Part No. 3615-SU .05 mfd., and in the 37-11 it is Part No. 3615-YU .05 mfd., .03 mfd.

Resistor locations in both receiver power units are slightly different as will be noted in Figs. 5 and 7.

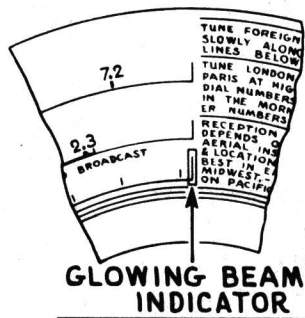

**Fig. 2. Dial Calibration**

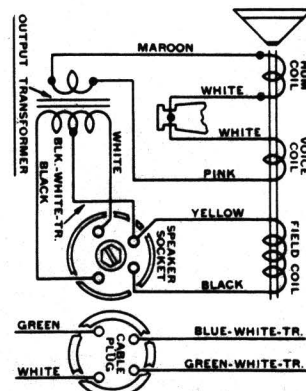

**Fig. 3. Speaker**

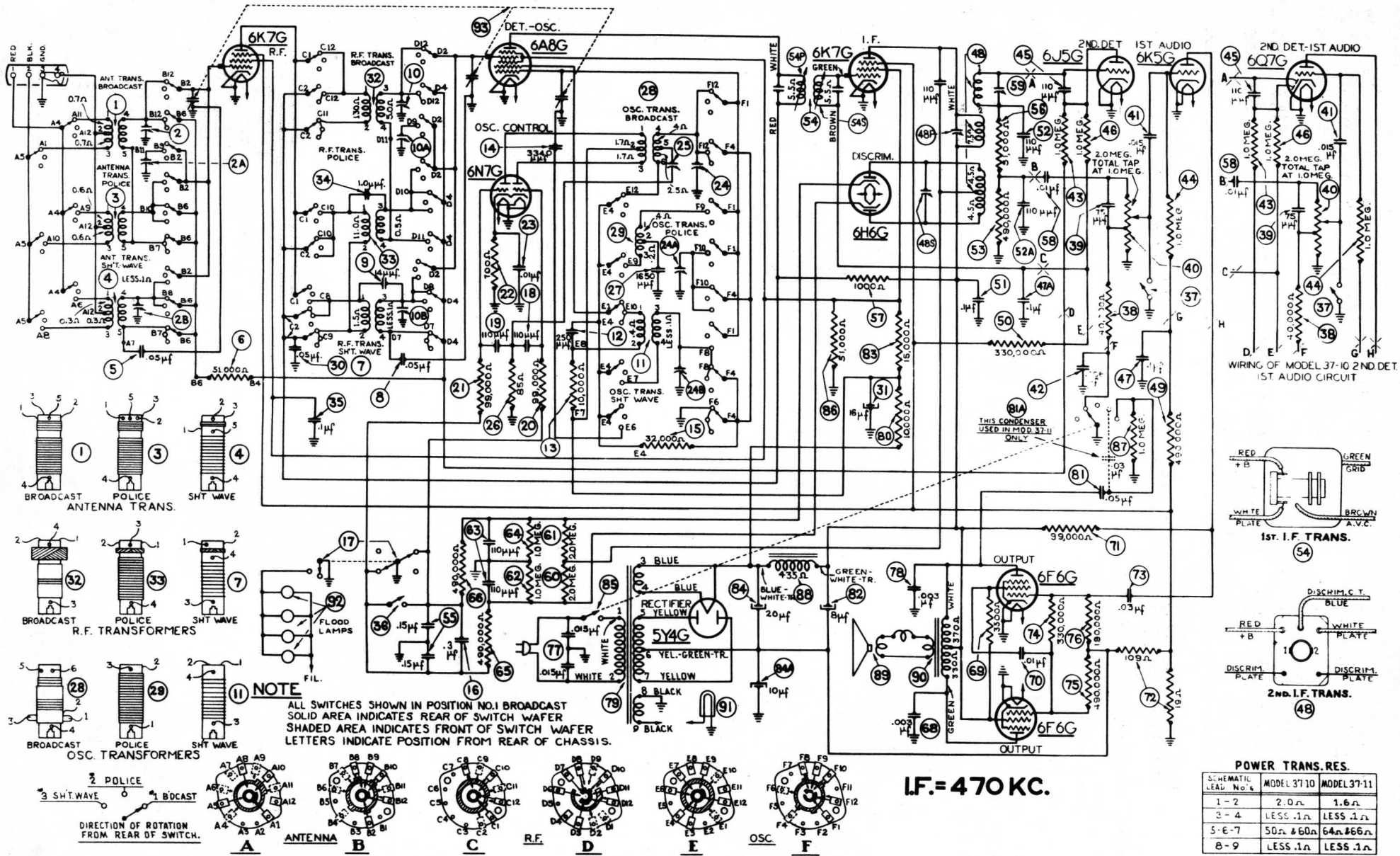

Fig 4. Schematic Diagram Models 37-10, 37-11

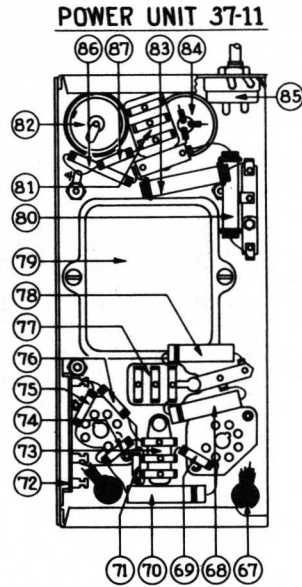

Fig. 5. 37-11 Power Unit Base View

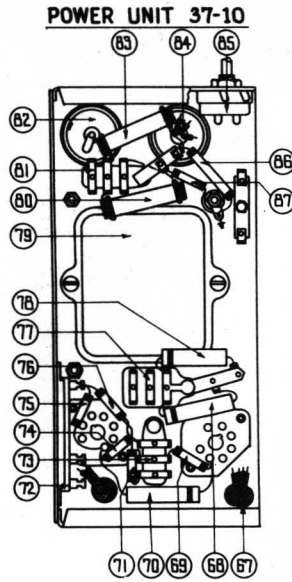
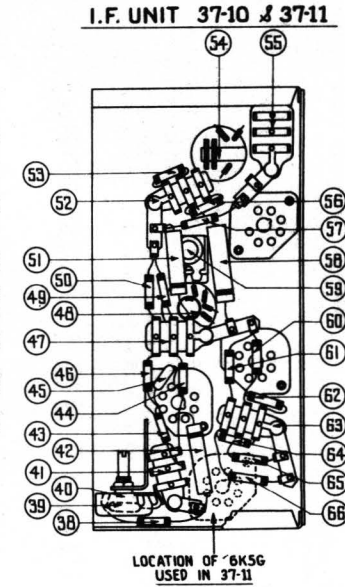
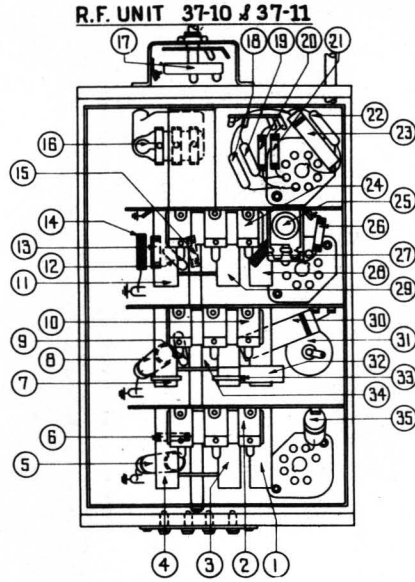

Fig. 6. 37-10-11 R. F., I. F. Base View and 37-10 Power Unit Base View



Replacement Parts—Models 37-10-11

Schem. No.	Description	Part No.	List Price
1	Antenna Transformer (Range 1)	32-2108	\$1.60
2	Compensator (Three section)	31-6092	.60
3	Antenna Transformer (Range 2)	32-2119	1.20
4	Antenna Transformer (Range 3)	32-2109	1.20
5	Condenser (.05 mfd. tubular)	30-4020	.20
6	Resistor (51,000 ohms, 1/2 watt)	33-351339	.20
7	R. F. Transformer (Range 3)	32-2126	.70
8	Condenser (.05 mfd. tubular)	30-4020	.20
9	Condenser (14 mmfd. mica)	30-1073	.20
10	Compensator (Three section)	31-6092	.60
11	Oscillator Transformer (Range 3)	32-2110	.70
12	Condenser (250 mmfd. mica)	30-1032	.20
13	Resistor (10,000 ohms, 1/2 watt)	33-310339	.20
14	Condenser (3340 mmfd. semi-fixed)	31-6152	.60
15	Resistor (32,000 ohms, 1/2 watt)	33-332339	.20
16	Condenser (.15 mfd. dual)	6287-DU	.40
17	Magnetic Tuning Switch	42-1269	.75
18	Condenser (.10 mmfd. mica)	30-1031	.20
19	Condenser (110 mmfd. mica)	30-1031	.20
20	Resistor (99,000 ohms, 1/2 watt)	33-399339	.20
21	Resistor (99,000 ohms, 1/2 watt)	33-399339	.20
22	Resistor (700 ohms)	33-1220	.20
23	Condenser (.01 mfd. tubular)	30-4169	.20
24	Compensator (Three section)	31-6149	.75
25	Compensator (Broadcast series)	31-6151	.40
26	Resistor (85 ohm, 1/2 watt)	33-085339	.20
27	Condenser (1650 mfd. semi-fixed)	31-6096	.40
28	Oscillator Transformer (Range 1)	32-2336	1.60
29	Oscillator Transformer (Range 2)	32-2121	.70
30	Condenser (.05 mfd. tubular)	30-4123	.20
31	Electrolytic Condenser (16 mfd.)	30-2118	1.65
32	R. F. Transformer (Range 1)	32-2105	1.00
33	R. F. Transformer (Range 2)	32-2106	.70
34	Condenser (Lug & Wire Twisted)	38-7878	.04
35	Condenser (.1 mfd. tubular)	30-4455	.20
36	Magnetic Tuning Switch (Automatic Dial)	45-2330	1.20
37	Audio Shorting Switch (Automatic Dial)	28-4110	.15
		45-2350	.15
	Washer Insulator for above switch	27-8361	.01
38	Resistor (40,000 ohms, 1/2 watt)	33-340339	.20
39	Condenser (75 mmfd. mica)	30-1053	.20
40	Volume Control	33-5158	1.00
41	Condenser (.015 mfd. bakelite)	3793-SU	.35

Schem. No.	Description	Part No.	List Price
42	Condenser (.006 mfd. tubular)	30-4445	\$0.20
43	Resistor (1.0 megohm, 1/2 watt)	33-510339	.20
44	Resistor (1.0 megohm, 1/2 watt)	33-510339	.20
45	Condenser (110 mmfd. mica)	30-1031	.20
46	Resistor (1.0 megohm, 1/2 watt)	33-510339	.20
47	Condenser (.1 mfd. dual bakelite)	4989-DG	.40
48	2nd I. F. & Discriminator Transformer	32-2362	3.30
49	Resistor (490,000 ohms, 1/2 watt)	33-449339	.20
50	Resistor (330,000 ohms, 1/2 watt)	33-433339	.20
51	Condenser (.1 mfd. tubular)	30-4455	.25
52	Condenser (110 mmfd. dual bakelite)	8035-DG	.25
53	Resistor (490,000 ohms, 1/2 watt)	33-449339	.20
54	1st I. F. Transformer	32-2333	2.20
55	Condenser (.15 mfd. dual bakelite)	6287-DG	.40
56	Resistor (51,000 ohms, 1/2 watt)	33-351339	.20
57	Resistor (1000 ohms, 1/2 watt)	33-210339	.20
58	Condenser (.01 mfd. tubular)	30-4479	.20
59	Compensator	31-6147	.40
60	Resistor (2 megohms, 1/2 watt)	33-520339	.20
61	Resistor (2 megohms, 1/2 watt)	33-520339	.20
62	Resistor (1 megohm, 1/2 watt)	33-510339	.20
63	Condenser (110 mmfd. dual bakelite)	8035-DG	.25
64	Resistor (1 megohm, 1/2 watt)	33-510339	.20
65	Resistor (490,000 ohms, 1/2 watt)	33-449339	.20
66	Resistor (490,000 ohms, 1/2 watt)	33-449339	.20
67	Speaker Cord	41-3258	.40
68	Condenser (.003 mfd. tubular)	30-4469	.20
69	Resistor (3500 ohms, 1/2 watt)	33-235339	.20
70	Condenser (.01 mfd. tubular)	30-4169	.20
71	Resistor (99,000 ohms, 1/2 watt)	33-399339	.20
72	Resistor (Bias)	33-3280	.30
73	Condenser (.03 mfd. bakelite)	8318-SU	.35
74	Resistor (330,000 ohms, 1/2 watt)	33-433339	.20
75	Resistor (490,000 ohms, 1/2 watt)	33-449339	.20
76	Resistor (190,000 ohms, 1/2 watt)	33-419339	.20
77	Condenser (.015 mfd. dual bakelite)	3793-DG	.40
78	Condenser (.003 mfd. tubular)	30-4469	.20
79	37-10 { Power Transformer (115 V., 50 to 60 cycles) } 32-7606 6.25		
	{ Power Transformer (115 V., 25 to 40 cycles) } 32-7607 9.00		
	{ Power Transformer (115-240 V., 50 to 60 cycles) } 32-7608 8.00		

Schem. No.	Description	Part No.	List Price
79	37-11 { Power Transformer (115 V., 50 to 60 cycles) } 32-7640		
	{ Power Transformer (115 V., 25 to 40 cycles) } 32-7641		
	{ Power Transformer (115-240 V., 50 to 60 cycles) } 32-7642		
80	37-10 Resistor (10,000 ohms, 2 watt)	33-310639	\$0.30
81	Condenser (.05 mfd. bakelite) 37-10	3615-SU	.35
	Condenser (.03, .05 mfd. bakelite) 37-11	3615-YU	
82	Electrolytic Condenser (8 mfd.)	30-2024	1.10
83	Resistor (15,000 ohms, 3 watt)	33-315639	.30
84	Electrolytic Condenser (10, 20 mfd.)	30-2183	2.00
85	Bass Comp. Control & A.C. switch (37-10)	42-1267	
	Bass Comp. Control & A.C. switch (37-11)	42-1268	
86	Resistor (51,000 ohms, 1 watt)	33-351439	.20
87	Resistor (1 megohm, 1/2 watt)	33-510339	.20
88	Speaker Field Assembly (H30)	36-3687	4.00
89	Cone Voice Coil (H30)	36-3801	.20
90	Output Transformer (H30)	32-7754	1.50
91	Pilot Lamp	34-2039	.07
92	Fluorescent Assembly	38-8210	2.40
93	Tuning Condenser	31-1948	3.75
	Antenna Terminal Panel	38-7714	.15
	Automatic Dial Assembly	31-1949	25.00
	Brace (Drive Mtg.)	28-4119	.05
	Bracket (Drive Mtg. Assembly)	31-1901	1.80
	Cable & Plug (Pilot lamps)	41-3253	
	Cable & Plug (Speaker)	41-3258	
	Cable Power	L-2183	.40
	Coupling Assembly (Tuning Shaft)	31-1961	
	Set Screws Assembly	W-650	.40 C
	Set Screws Assembly	W-644	1.50 C
	Control Screws (Station Index)	31-1898	.15
	Dial	27-5271	1.00
	Dial Guide	27-8580	.03
	Dial Screen Holder	31-1968	
	Dial Escutcheon Assembly	45-2324	.40
	Gear No. 1 Front (Dial Assembly)	45-2347	.25
	Gear No. 2 Rear (Dial Assembly)	45-2348	.60
	Handle (Dial)	45-2329	.10
	Handle (Hub Assembly)	45-2344	.10
	Housing (Control Screw)	28-7196	1.00
	Mask Guide	28-4118	.25

Schem. No.	Description	Part No.	List Price
	Mask	27-5272	\$0.60
	Mask & Link Assembly	45-2367	
	Pilot Lamp Assembly	38-8407	
	Pilot Lamp Assembly (Auto Dial)	38-8210	2.40
	Ring (Retaining Handle Hub)	28-8630	.02
	Ring (Retaining Mask Assembly)	28-7195	.20
	Reflector Ring	28-4099	.35
	Range Switch Ant.	42-1200	
	Range Switch R. F.	42-1245	
	Range Switch Osc.	42-1274	
	Range Switch Index Plate & Shaft	42-1265	.50
	Range Switch Shaft Coupling	28-7198	.15
	Station Tab Kit	40-6056	
	Set Screw	W-481	2.00 C
	Socket (7 Prong)	27-6057	
	Socket (8 Prong)	27-6058	
	Socket (Rectifier)	27-6052	
	Shield (Tube) (Square)	27-2726	.10
	Shield Base	28-3898	.03
	Shield Tube (Round)	8005	.10
	Shaft (Volume Control)	38-8198	
	Paper Tube (Vol. Shaft)	27-8530	.01
	Retaining Clip (Vol. Shaft)	28-4394	.01
	Spring (Vol. Shaft)	28-4117	.40 C
	Spring (Mask retaining ring)	28-8629	.04
	Speaker (H-30)	36-1295	
	Vernier Drive	45-2342	2.40
	Washer (Dial ring contact)	27-8361	
	Washer (Dial scale)	27-8398	.01
<b>CABINET PARTS</b>			
<b>37-10</b>			
	Baffle (Wood) (Speaker)	23553	
	Baffle & Silk Assembly	40-5076	.60
<b>37-11</b>			
	Baffle & Silk Assembly	40-6015	
	Baffle (Wood) (Speaker)	24231	
<b>37-10-11</b>			
	Bezel Assembly	40-5980	1.00
	Cover (Bezel)	28-4077	.25
	Gasket (Bezel)	27-8517	.05
	Knob (Range Switch)	27-4326	.10
	Knob (Tuning)	27-4330	.10
	Knob (Tuning Vernier)	27-4331	.10
	Knob (Tone & Volume)	27-4332	.10

Prices Subject to Change Without Notice

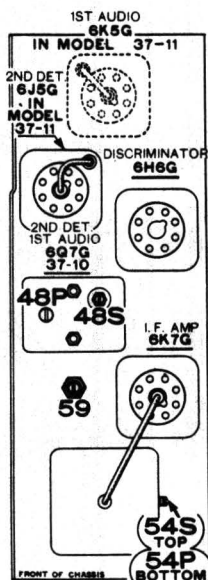

Fig. 7

### Alignment of Compensators

**EQUIPMENT REQUIRED:** (1) Signal Generator; Philco Model 088 (fundamental frequency 110 to 20,000 K. C.) is the correct instrument for this purpose; (2) Output meter; Philco Model 025 Circuit Tester incorporates a sensitive output meter and is recommended; (3) Fibre handle screw-driver (Philco Part No. 27-7059); (4) Special variable condenser (Philco Part No. 45-2325).

**OUTPUT METER:** The 025 Output Meter is connected to the plate and cathode terminals of one of the (6F6G) tubes. Adjust the meter to use the (0-30) volt scale.

#### INTERMEDIATE FREQUENCY CIRCUIT

- Set controls as follows:
  - Magnetic Tuning "off"
  - Bass compensation minimum
  - Volume control maximum
  - Receiver Dial 580 K. C.
  - Signal Generator 470 K. C.
- Adjust the I. F. compensators for maximum with signal generator output lead connected through a .1 mfd. condenser to the grid of the tubes as follows:

Input Point	Compensators in Order
6K7G—1st I. F.	(59) (48P)
6A8G—1st Det.	(54S) (54P)

#### RADIO FREQUENCY CIRCUIT

- Tuning Range 7.35 to 22 M. C.**
- Connect the signal generator output lead through a .1 mfd. condenser to terminal 1 and the generator ground to terminal 3 on aerial input panel. Terminals 2 and 3 must be connected with the shorting link provided on the aerial panel.
  - Other controls set as given under intermediate frequency circuit, with the exception of those as follow:

Range Switch	Signal Generator	Receiver Dial	Compensators in Order
3	18 M. C.	18 M. C.	(24B) See Note A
3	18 M. C.	18 M. C.	(10B) (2B) Use shunt condenser on (24B) (Note B)
3	18 M. C.	18 M. C.	(24B) (Note A)

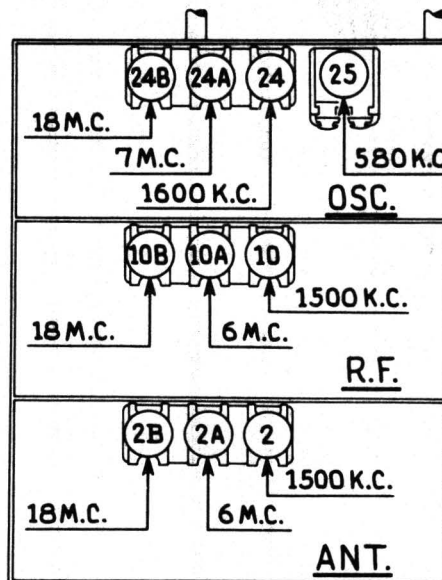

Fig. 8. R. F. Compensators, Underside of Chassis

#### Tuning Range 2.3 to 7.4 M. C.

Adjust compensators for maximum as follows:

Range Switch	Signal Generator	Receiver Dial	Compensators in Order
2	7 M. C.	7 M. C.	(24A)
2	6 M. C.	6 M. C.	(10A) (2A)

#### Tuning Range 530 to 1720 K. C.

Adjust compensators for maximum as follows:

Range Switch	Signal Generator	Receiver Dial	Compensators in Order
1	1600 K. C.	1600 K. C.	(24) (10) (2)
1	580 K. C.	580 K. C.	(25) Roll gang
1	1600 K. C.	1600 K. C.	(24)
1	1500 K. C.	1500 K. C.	(10) (2)

#### MAGNETIC TUNING ADJUSTMENT

Set the range switch in position one (530 to 1720 K. C.) and the magnetic tuning switch in the "out" position. Now turn the signal generator and receiver dial to any frequency in the Broadcast band. The receiver dial must be adjusted very accurately for maximum output.

Set the magnetic tuning control in the "on" position (clockwise). Compensator (48S) of the magnetic tuning transformer is now adjusted for maximum output.

The above adjustment is now checked for accuracy, by turning the magnetic tuning control "off" and "on". When this is done, there should be no change in the tone of the received signal. If a change of tone or hiss develops, it indicates a shift in frequency and the adjustment must be made again.

**NOTE "A"**—To accurately adjust the compensator to the fundamental and not the image signal, turn the oscillator compensator to the maximum capacity position clockwise. Then slowly turn the compensators counter-clockwise until a second maximum peak is obtained on the output meter. The first peak is the image signal and the receiver must not be adjusted to it. If the above procedure is correctly performed, the image signal will be found 940 K. C. below the frequency being used.

**NOTE "B"**—To eliminate the effect of the R. F. compensator detuning the Osc. circuit, a variable tuning condenser, Philco Part No. 45-2325 is connected from the oscillator compensator to ground when designated in the padding instruction above. Tune the added condenser until the second harmonic of the receiver oscillator beats against the signal from the generator, resulting in a maximum indication on the output meter. Then adjust compensators as noted for maximum output.

## A Necessity FOR EFFICIENT SERVICING

Here is a piece of equipment that any dealer or service station owner can use in many ways both for service and profit. Ruggedly and attractively constructed of heavy steel, cadmium plated, this rack is ideal for speedy testing and working on all standard sized radio chassis.

It is also especially suitable for arranging special window displays of chassis. Four adjustable support arms with wing nuts permit use of any size or shape chassis with equal ease.

Order one from your Philco distributor today.

### New PHILCO CHASSIS-RACK for SHOP WORK or DISPLAY USE

Dimensions overall:  
Height 11¾" Depth 14" Length 17"

PART No. 45-2310 LIST PRICE \$600

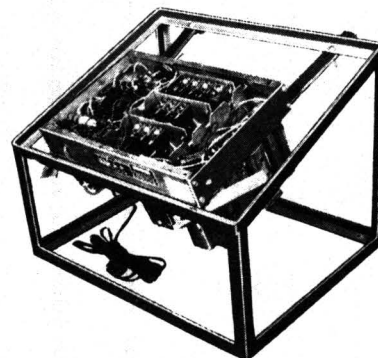

PHILCO RADIO AND TELEVISION CORPORATION  
Philadelphia, Pa.