

PHILCO



SERVICE

HOME RADIO

PHILCO RADIO-PHONOGRAPH, MODEL 46-1213

SPECIFICATIONS

CABINET	Model 46-1213: Mahogany finish console.
CIRCUIT	Eleven-tube superheterodyne
FREQUENCY RANGES	
Broadcast	540-1720 kc.
Short wave	9.3-15.5 mc.
FM	88-108 mc.
POWER OUTPUT	10 watts
PUSH BUTTONS	Ten: One for ON-OFF, five for broadcast station selection, three for band selection, and one for phono operation.
OPERATING VOLTAGE	105 to 120 volts, 60 cycles, A.C.
POWER CONSUMPTION	125 watts
AERIALS	Built-in cabinet loop, dipole, or external aerial.
INTERMEDIATE FREQUENCIES	
AM	455 kc.
FM	9.1 mc.
PHILCO TUBES USED	7AF7, 7B7, 7F8, 7H7(2), 7W7, FM1000, 6SQ7GT/G, 6V6GT/G(2), 5U4G
RECORD PLAYER	M-4 Automatic Changer—Part No. 35-1297
PANEL LAMPS	(3) 6—8-volt, Part No. 34-2040
BIN LAMP	115-volt—Part No. 34-2484



CIRCUIT DESCRIPTION

Philco Radio-Phonograph Model 46-1213 contains an eleven-tube superheterodyne radio, providing reception on the standard broadcast band, 540 to 1720 kc., the short-wave band, 9.3 to 15.5 mc., and the FM band, 88 to 108 mc.

A low-impedance loop within the cabinet provides adequate signal pickup for the broadcast and short-wave bands. In most locations, the built-in FM aerial provides satisfactory reception on the FM band. In areas where FM signals are weak, an outdoor dipole aerial (Philco Part No. 45-1462) will provide additional pickup.

The r-f stage (FM only), converter stage, and first i-f stage are mounted on a separate chassis to insure reliable performance at high frequencies. A 7W7 high-frequency pentode tube is used in the r-f stage, and a 7F8 high-frequency double-triode tube is employed as a converter. These stages provide high signal-to-noise ratio, high conversion efficiency and good image rejection. The FM tuning gang is constructed with copper plates to obtain the high Q required for proper selectivity.

Three transformer-coupled i-f stages are used. The first, third, and fourth i-f transformers have two sets of windings: one set is tuned to 455 kc. for AM operation, the other to 9.1 mc. for FM operation. The second i-f transformer, having a single primary

winding tuned to 9.1 mc., a secondary winding tuned to 9.1 mc., and another secondary tuned to 455 kc., provides untuned-primary tuned-secondary coupling on AM to prevent instability. All transformers provide tuned-primary, tuned-secondary coupling on FM to supply the additional gain needed at 9.1 mc. Switching of the windings, to attenuate undesired beat-frequencies, is necessary only in the first i-f transformer. The large difference between intermediate frequencies makes further switching unnecessary. One 7B7 and two 7H7 high-transconductance pentodes are used in the i-f stages.

The new Philco advanced FM detector circuit, employing the new FM1000 tube of special design, is used for FM reception. This circuit has excellent tuning characteristics and inherently rejects AM and noise. Very briefly, the circuit functions as follows: The first and second grids (pins No. 2 and 5) of the FM1000 tube are used as grid and anode, respectively, of a modified Colpitts oscillator which nominally operates at the intermediate frequency of 9.1 mc. The output of the i-f amplifier stages is fed into the injection grid (pin No. 6) of the FM1000 tube. The reactive coupling between the plate circuit of the FM1000 and the oscillator circuit causes the oscillator to lock in and follow the frequency variations of the i-f signal. The effect of the fore-

going combination of elements is such that as the oscillator frequency increases, the plate current through R302 decreases, and as the oscillator frequency decreases, the plate current increases. This variation is linear with respect to frequency deviation; the plate current, therefore, produces the same wave shape as the modulation of the FM carrier. This audio signal is fed to the audio amplifier through the decoupling network, C304 and R303.

The high-mu-triode section of a 6SQ7GT/G tube is used in the first audio stage and is biased from the bleeder in the negative return of the power supply. The first audio stage is resistance coupled to one triode section of a 7AF7 twin-triode tube. This section of the tube functions as a cathode-and-plate-loaded phase inverter and is resistance coupled to the audio-output stage, which employs two 6V6GT/G beam-pentodes in push-pull combination. The output tubes are transformer coupled to a twelve-inch electro-dynamic speaker, and are biased from the bleeder circuit connected across the speaker field in the negative return of the power supply. Inverse feed-back is obtained by connecting the secondary of the output transformer, through the resistor network R204 and R202, to the volume control. The second triode section of the 7AF7 tube is used as the phonograph pre-amplifier stage, and is self-biased by cathode resistor R213.

PHILCO TROUBLE-SHOOTING PROCEDURE

In this manual, the circuit is divided into five sections which are shown both in schematic and chassis-base layouts, with test points for each section. The first step in the chart makes it possible to determine whether trouble exists in the section without going through the entire test procedure. Wherever trouble is indicated (by failure to get the "NORMAL INDICATION" in a given test), it should be located by voltage, resistance, or capacity checks of the parts associated with the point under test, and remedied before testing further.

All components in the radio circuit are symbolized. The significance of these symbols in identifying the types and circuit location of parts may be understood by referring to the front page of the service manual for PHILCO RADIO, MODEL 46-350.

PRELIMINARY CHECKS

Before starting the trouble-shooting procedure, the following steps are recommended:

1. Before connecting the radio to a source of power, inspect both top and bottom of the chassis. Make sure that all tubes are secure in their proper sockets, and look for any broken or shorted connections, burned resistors, or other obvious sources of trouble.

2. Measure the resistance between B+ (pin No. 2 of 5U4G rectifier tube) and the radio chassis. When the ohmmeter test leads are connected in proper polarity, the highest resistance reading will be obtained. If this reading is lower than 50,000 ohms, check condensers C101A, C101B, C101C, C102, C103, C104 for leakage or shorts.

CALIBRATING DIAL BACKPLATE

When the radio chassis has been removed from the cabinet, dial calibration and alignment points may be marked on the dial backplate below the pointer.

The method of measuring for these points is illustrated in figure 1. Hold a rule against the dial backplate, with the start of the rule against the inside of the upturned edge of the backplate.

Mark pencil dots at the proper points for the desired frequency settings. The index mark should be located 3-1/2 inches from the inside of the upturned edge of the backplate.

With the tuning gang fully meshed, the pointer should be adjusted on the dial-drive cord to coincide with the index mark.

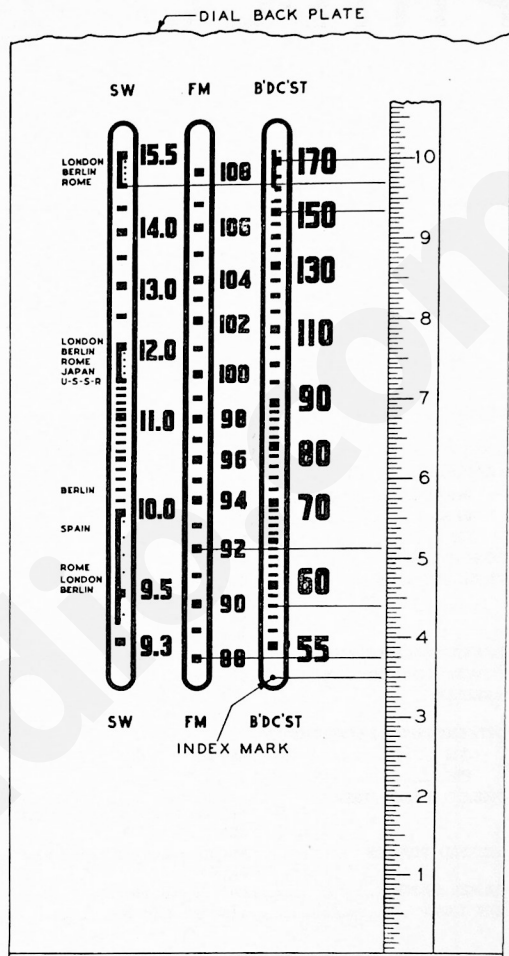

Figure 1. Dial-Backplate Calibration Measurements

AUTOMATIC RECORD CHANGER, MODEL M-4

Service data on the Model M-4 Automatic Record Changer is not included in this manual. Complete service information on this changer is contained in the service manual for Philco Automatic Record Changer, Model M-4, PR-1157.

REMOVING CHASSIS FROM CABINET

The chassis of Model 46-1213 is fastened to a wooden mounting board, which in turn is bolted to the cabinet. To remove the chassis from the cabinet, remove the four hex-head nuts that hold the mounting board to the cabinet and take out the chassis and mounting board as a unit. To service the chassis, remove the mounting board and metal cover.

To take the chassis completely from the cabinet, it is necessary to unfasten the bin light and bin-light switch. Remove the phonograph-compartment back for this operation.

Be careful when reinstalling the chassis, making certain that all leads in the phonograph compartment are arranged so as not to interfere with the operation of the mechanism.

TESTS TO ISOLATE TROUBLE WITHIN SECTION 1

CAUTION

Do not turn on radio power with speaker disconnected, as this will cause damage to the instrument.

All measurements in this section were made with a 20,000-ohms-per-volt meter. Using the applicable d-c range, connect the meter across the various test points indicated in the test chart. The voltages given in this manual are average and were measured with the radio connected to a 117-volt, 60-cycle, a-c power source, without signal input. The voltage may be considered normal if it is within $\pm 10\%$ of the indicated values.

Turn volume control and bass tone control fully counterclockwise, and treble tone control fully clockwise. Depress the BC push button. If the "NORMAL INDICATION" is obtained in the first step, proceed to the tests for Section 2; if not, isolate and remedy the trouble in this section. It will be noted that certain parts in other sections of the receiver are listed under "POSSIBLE CAUSE OF ABNORMAL INDICATION".

STEP	TEST POINTS	NORMAL INDICATION	ABNORMAL INDICATION	POSSIBLE CAUSE OF ABNORMAL INDICATION
1	B to C D to C	200 volts 220 volts		Trouble within Section 1. Isolate by following tests.
2	A to C	280 volts	No voltage Low voltage High voltage	Defective 5V4G tube or T100. Shorted C101C, C102, C103, C104, or C415. Open L100 or R105. Defective C103, or 5V4G tube. Leaky C101C, C102, C104, C415. 6V6GT/G tube, or T200. Shorted C105, C409, C414, C419, or T100. Open R102. Defective 6V6GT/G tube. Open R103 or T200.
3	B to C	200 volts	No voltage Low voltage High voltage	Open R101. Shorted C101B or C518. Leaky C101B or C518. Shorted C517. R101 changed in resistance value. Defective 6V6GT/G tube.
4	D to C	220 volts	No voltage Low voltage	Open R100. Shorted C101A. See step 3. R100 changed in resistance value. Leaky C101A.

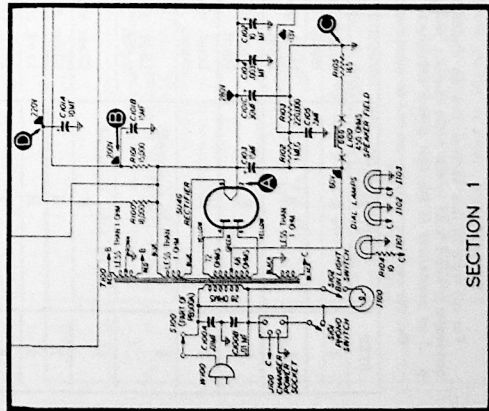

Figure 2.
Section 1 schematic.

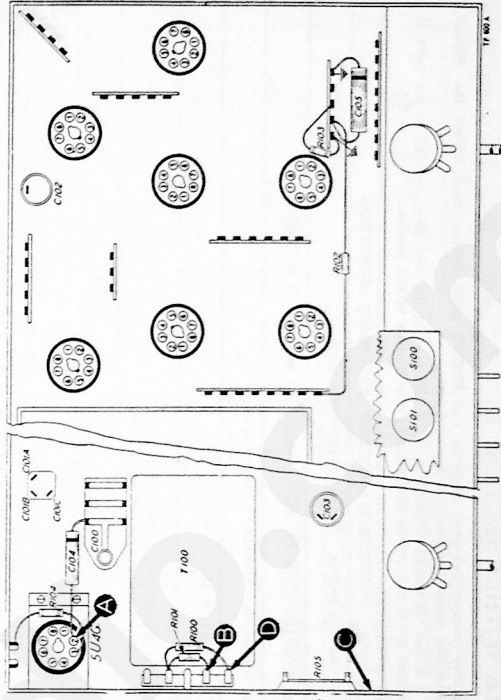

Figure 3.
Bottom view, showing
Section 1 test points.

TESTS TO ISOLATE TROUBLE WITHIN SECTION 2

For all tests in this section, use an audio-frequency signal generator. Connect the generator ground lead to the radio chassis, test point C; connect the output lead through a .1-mf condenser to the test points indicated.

Set the receiver volume control at maximum, treble tone control clockwise, b.c.s.s. tone control counterclockwise; depress the PHONO push button, and adjust the signal generator output as required for each step.

If the "NORMAL INDICATION" is obtained in the first step, proceed to the tests in Section 3. If not, isolate and remedy the trouble in this section.

STEP	TEST POINT	NORMAL INDICATION	POSSIBLE CAUSE OF ABNORMAL INDICATION
1.	L	Loud, clear signal output with weak signal input.	Trouble within this section. Isolate by following tests.
2	A	Loud, clear signal output with strong signal input.	Defective 6V6GT/G, T200, or LS200. Shorted or leaky C210 or C208.
3	B	Loud, clear signal output with strong signal input.	Defective 6V6GT/G. Shorted or leaky C206.
4	D	Loud, clear signal output with strong signal input.	Open C209, R219, R220.
5	(7AF7 tube removed) E	Loud, clear signal output with strong signal input.	Open C206 or R211.
6	(7AF7 tube replaced) F	Clear signal, louder than preceding test.	Defective 7AF7 tube. Open R219, R212, R211. Leaky C205.
7	G	Clear signal, same volume as step 6.	Open C205.
8	H	Loud, clear signal with moderate signal input.	Defective 6SQ7GT/G tube. Open R209.
9	I	Loud, clear signal with moderate signal input.	Defective R203 (rotate through entire range). Open C201.
10	K	Loud, clear signal with moderate signal input.	Open C207 or R216. Defective PB500B.
11	L	Loud, clear signal with weak signal input.	Defective 7AF7 tube. Open R214, R217, R218, or R213. Shorted C208.

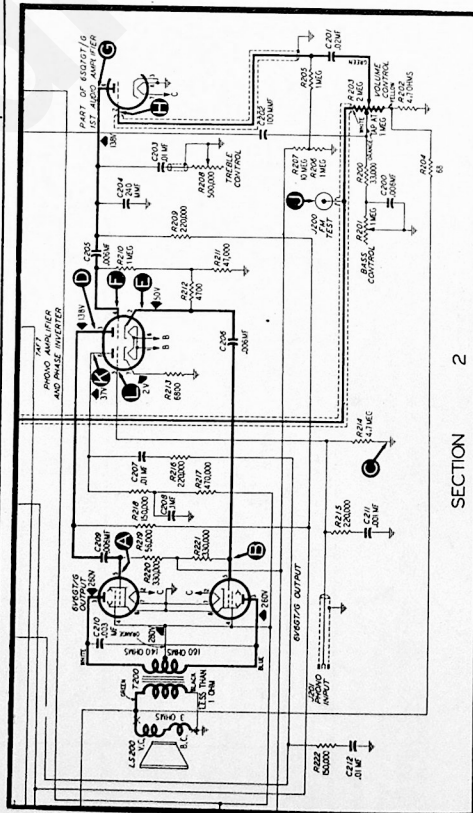

Figure 4. Section 2 schematic.

SECTION 2

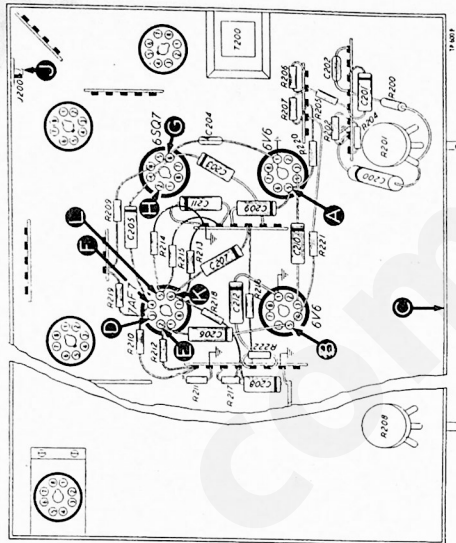

Figure 5. Bottom view, showing Section 2 test points.

1P-600G

TESTS TO ISOLATE TROUBLE WITHIN SECTION 3 (FM DETECTOR)

The tests in this section are made with an audio-frequency generator, an AM r-f signal generator, and a 20,000-ohms-per-volt voltmeter. Use a .1-mf condenser in series with the output lead of each generator.

In Step 1, unmodulated r-f signals together with d-c voltage readings are used to check the response of the detector circuit to FM by observing the voltage drops across the audio-load resistor (R302) for different input frequencies within the i-f range of the detector. In Step 3, the oscillator section of the FM detector is made inoperative, thereby converting the circuit to an AM detector and making it possible to check certain components with an AM signal. The tests in this section will not indicate the condition of alignment of the detector unless the circuit is extremely misaligned.

NOTE: In Steps 1 and 3, the AM signal-generator output must be at least .5 volt. If the output is insufficient, the generator lead may be connected to test points A or B in Section 4, depending upon the maximum output of the generator used. When using these test points, it is assumed that the last two i-f stages are trouble-free. The last two i-f stages may be at fault, however, if abnormal indications are obtained in BOTH steps. Test i-f stages as given in Section 4, FM Circuits, if doubtful.

Set the radio controls as follows: volume control at maximum; bass control fully counterclockwise; treble control fully clockwise; FM push button (PB500H) depressed. Proceed with the tests. If the "NORMAL INDICATION" is obtained in the first test, proceed to the tests for Section 4; if not, isolate and remedy trouble in this section.

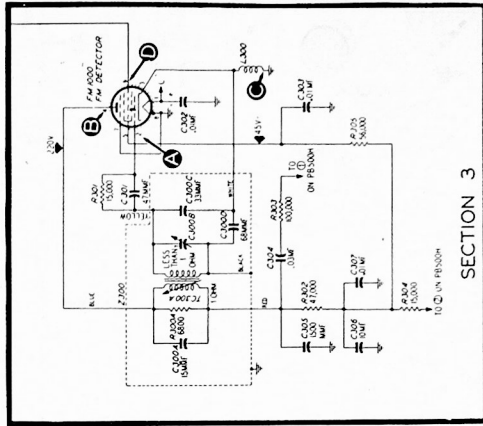

Figure 6. Section 3 schematic.

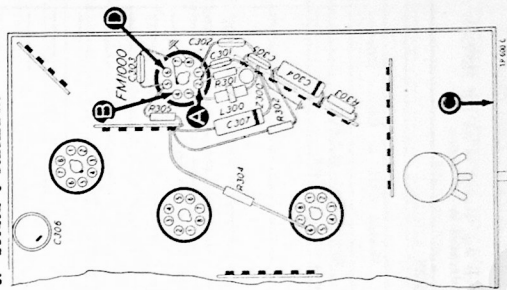

Figure 7. Bottom view, showing Section 3 test points.

STEP	PROCEDURE	NORMAL INDICATION	POSSIBLE CAUSE OF ABNORMAL INDICATION
1	Connect d-c voltmeter across resistor R302 (positive lead to junction of R302 and R304; negative lead to junction of R302 and C304), with meter on 50-volt range. Turn off modulation and adjust generator output to approximately .5 volt. Swing generator frequency from approximately 80 kc above to 80 kc below 9.1 mc.	Approximately 15 volts across R302 for 9.1-mc signal or no signal; 8 volts for 80 kc above 9.1 mc; 23 volts for 80 kc below 9.1 mc.	Trouble within this section. Isolate by following tests.
2	Connect audio-signal generator to test point D; adjust for high generator output.	Loud, clear signal output from receiver.	Defective Z300, FM1000, PB500H, Shorted C305. Open C304, R303.
3	Short test point A (pin No. 2, FM 1000) to chassis. Connect r-f generator output to test point D. Use modulated signal. Set generator to 9.1-mc and maximum output.	Loud, clear signal output from receiver.	Shorted C306, C307. Open R304, L300. Defective FM1000 tube. Open R302.
4	Remove short from test point A. Connect negative lead of d-c voltmeter to test point A through a 50,000-ohm resistor and positive lead to test point C (chassis). Set meter to 10-volt range.	Approximately 2.5 volts negative. (Osc. grid voltage.)	Defective FM1000 tube, Z300, L300, C301. Shorted C303. Open R305, R301.

TESTS TO ISOLATE TROUBLE WITHIN SECTION 4 AM CIRCUITS

For the AM circuit tests in this section, use an AM r-f signal generator with frequency set in 455 kc. Connect the signal-generator ground lead to the radio chassis, test point C; connect the output lead through a .1- μ f condenser to the test points indicated. Depress the BC push button (PB500H), set the volume control at maximum, the bass control fully counterclockwise, and the treble control fully clockwise. Adjust the signal-generator output as required for each step.

STEP	TEST POINT	NORMAL INDICATION	POSSIBLE CAUSE OF ABNORMAL INDICATION
1	E	Clear signal with weak signal input.	Trouble within this section. Isolate by following tests.
2	A	Clear signal with strong signal input.	Defective or misaligned Z403. Open R414, R416, C424. Defective 6SQ8GT/G tube. Shorted C422 or C423. Defective PB500B, 7H7. Open R410, R411, or R412. Shorted C417, C418.
3	B	Clear signal, louder than step 2.	Defective or misaligned Z402. Defective 7B7 tube. Open R406, R407, R408, or R409. Shorted C413, or C412.
4	D	Clear signal, louder than step 3.	Defective or misaligned Z401. Defective 7H7 tube. Open R402, R403, or R404. Shorted C408, or C406.
5	E	Clear signal, louder than step 4 (using weak signal input).	Defective or misaligned Z400.

FM CIRCUITS

For the FM circuit tests in this section, short test point A, in Section 3, to the radio chassis to permit use of an AM signal. Connect the AM signal-generator ground lead to the radio chassis, test point C; connect the output lead through a .1- μ f condenser to the test point indicated in the test chart. With the exceptions of the i-f switch, tubes, and transformers (all of which may function properly at 455 kc, but not at 9.1 mc) and the parts specified in the chart, the parts in Section 4 which are normal are as follows:

STEP	TEST POINT	NORMAL INDICATION	POSSIBLE CAUSE OF ABNORMAL INDICATION
1	E	Loud, clear signal with weak signal input.	Trouble within this section. Isolate by following tests.
2	A	Clear signal with strong signal input.	Defective or misaligned Z403. Defective C421, 6SQ7GT/G tube (shorted diode). Defective 7H7 tube.
3	B	Loud, clear signal with moderate signal input.	Defective or misaligned Z402. Defective 7B7 tube.
4	D	Loud, clear signal with weak signal input.	Defective or misaligned Z401. Defective 7H7 tube.
5	E	Loud, clear signal with weak signal input.	Defective or misaligned Z400.

POSSIBLE CAUSE OF ABNORMAL INDICATION

Trouble within this section. Isolate by following tests.
 Defective or misaligned Z403. Defective C421, 6SQ7GT/G tube (shorted diode). Defective 7H7 tube.
 Defective or misaligned Z402. Defective 7B7 tube.
 Defective or misaligned Z401. Defective 7H7 tube.
 Defective or misaligned Z400.

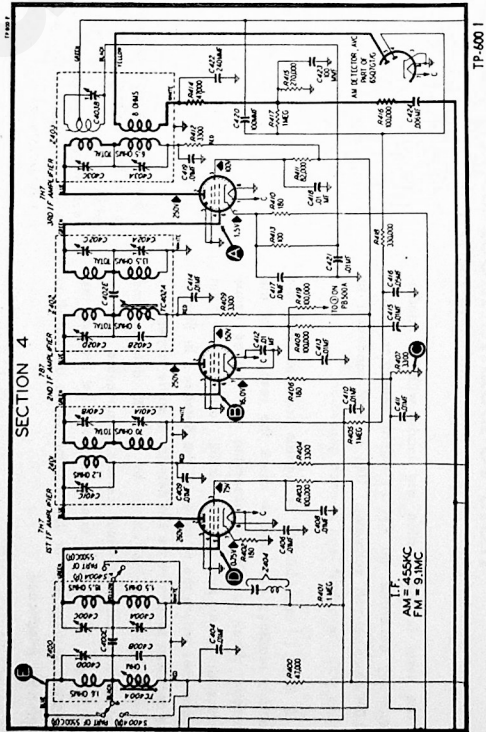

Figure 8. Section 4 schematic.

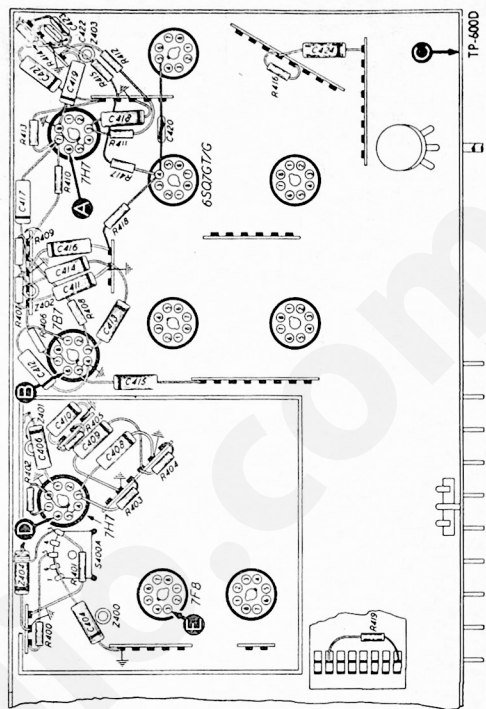

Figure 9. Base view, showing Section 4 test points.

TESTS TO ISOLATE TROUBLE WITHIN SECTION 5 AM CIRCUITS

For the signal tests, use an r-f signal generator with amplitude-modulated output. Connect the signal-generator ground lead to the radio chassis, test point C; connect the output lead through a .1-mf condenser to the test points indicated. Turn the radio volume control to maximum, the treble tone control fully clockwise, the bass tone control fully counterclockwise, and set the signal generator for weak generator output.

OSCILLATOR TESTS: For steps 5, 8 and 10, connect the positive lead of a 20,000-ohms-per-volt meter to test point E, and the prod end of the negative lead through a 100,000-ohm isolating resistor to test point D. Read the voltage on the 10-volt range. Absence of voltage at any dial or band position indicates that the oscillator is not functioning properly; check the parts listed in the chart for the oscillator tests.

STEP	TEST POINTS	SIGNAL-GEN. SETTING	PUSH BUTTON OR TUNING CONTROL	NORMAL INDICATION	POSSIBLE CAUSE OF ABNORMAL INDICATION
1	B	Vary through range of each push button.	Depress, in order, PB500C to PB500G.	Loud, clear signal when each push button is depressed.	Trouble within push-button band. Isolate by steps 4, 5, and 6.
2	B	1000 kc	Depress BC push button (PB500K). Tune receiver to signal.	Loud, clear signal.	Trouble within BC band. Isolate by steps 7 and 8.
3	F	12 mc	Depress SW push button (PB500J). Tune receiver to signal.	Loud, clear signal.	Trouble in short-wave section. Isolate by steps 9 and 10.
4	A	Adjust to frequency of push button.	Depress PB500E.	Loud, clear signal.	Defective 7F8 tube. Open R510 or C515. Defective S500A(F).
5	D to E (See OSCILLATOR TESTS)		Depress, in order, PB500C to PB500G.	Negative voltage.	No voltage for any one push button: Defective coil L500A to L500E) or push button. No voltage for all push buttons: Defective 7F8 tube, S500B, PB500J, PB500K, or C509. Open R504, R505, C516, R508, C508, C508, L506, R507, L505, L501C, or C514. Shorted C502B or C501.
6	B	Vary through range of each push button.	Depress, in order, PB500C to PB500G.	Loud, clear signal.	Defective TB500, L502, C502A, C500A to C500E. Open C505, R509, or R511.
7	B	1000 kc	Depress BC push button (PB500K). Tune to signal from generator.	Loud, clear signal.	Defective C501, PB500K.
8	D to E (See OSCILLATOR TESTS)		Depress BC push button (PB500K). Rotate radio tuning control through entire range.	Negative voltage over entire tuning range.	Defective L505.
9	F	12 mc	Depress SW push button. Tune to signal from generator.	Loud, clear signal.	Defective J500, L503, L507, C503, or C504.
10	D to E (See OSCILLATOR TESTS)		Depress SW push button. Rotate tuning control through entire range.	Negative voltage over entire tuning range.	Defective 7F8 tube, L504, C502C or C507. Open C508.

FM CIRCUITS

Before proceeding with the FM circuit tests, connect test point A, in Section 3, to the radio chassis. Follow the same general procedure as given under AM TESTS.

STEP	TEST POINTS	SIGNAL-GEN. SETTING	PUSH BUTTON OR TUNING CONTROL	NORMAL INDICATION	POSSIBLE CAUSE OF ABNORMAL INDICATION
1	H	100 mc	Depress FM push button (PB500H). Tune to signal.	Loud, clear signal.	Trouble in FM band. Isolate by following tests.
2	D to E (See OSCILLATOR TESTS in AM TESTS).		Depress FM push button (PB500H). Rotate tuning control through entire range.	Negative voltage over entire range.	Defective 7F8 tube, S500B(F), L501C, C501, C501C, PB500H. Open R506. Shorted C517.
3	G	100 mc	Depress FM push button (PB500H). Tune to signal.	Loud, clear signal.	Defective C513, L501B, C501, C501B, or S500A(F).
4	H	Same	Same	Loud, clear signal.	Defective J500, L501A, C501, C501A, 7W7 tube, Open C510, R500, R501, R502, R503. Shorted C511, C512, or C519.

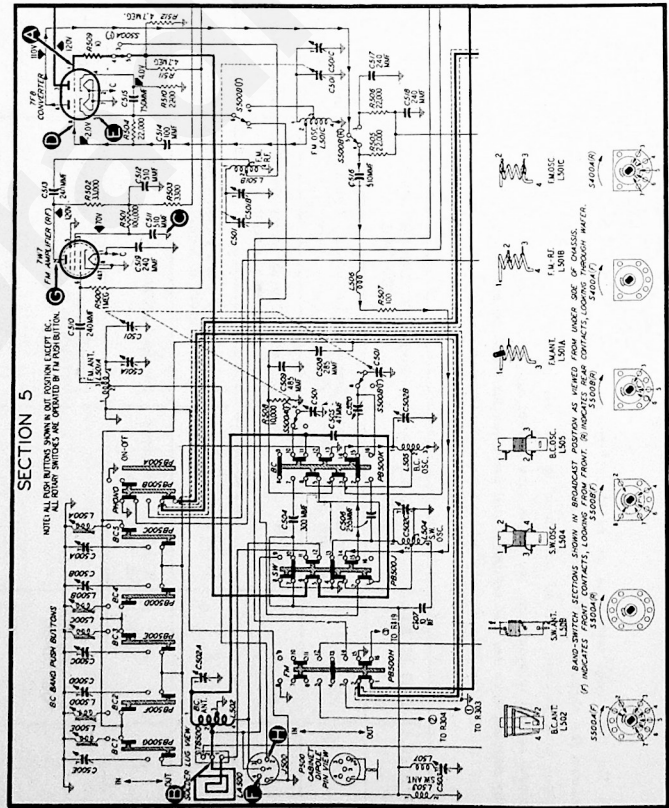

Figure 10. Section 5 schematic.

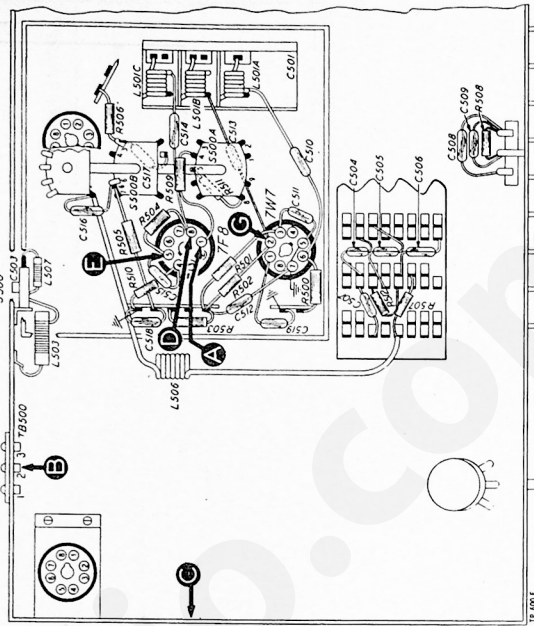

Figure 11. Base view, showing Section 5 test points.

ALIGNMENT PROCEDURE

CAUTION: Do not turn on radio power with speaker disconnected, as this will cause damage to the instrument.

ALIGNMENT OF AM CIRCUITS

When the complete AM and FM alignment is to be made, the AM alignment should be made **FIRST**; however, if FM alignment is not required, the AM alignment alone may be made. **OUTPUT METER:** Connect between No. 3 terminal (voice-coil connection) of aerial terminal panel and chassis. **AM SIGNAL GENERATOR:** Connect the ground lead to radio chassis, and the output lead as indicated in chart. **OUTPUT LEVEL:** During the alignment, the signal-generator output must be attenuated to maintain the radio output below 1.5 volts, as read on the output meter.

CONTROLS: Set volume control at maximum, bass tone control in counterclockwise position, treble tone control in clockwise position, and the signal-generator dial, radio dial, and radio band switch as indicated in the chart. **DIAL POINTER:** With tuning condenser fully closed, the dial pointer must coincide with reference mark at low-frequency end of scale.

SIGNAL GENERATOR (AM)			RADIO			
STEP	CONNECTIONS TO RADIO	DIAL SETTING	BAND SWITCH	DIAL SETTING	SPECIAL INSTRUCTIONS	ADJUST TRIMMER
1	Through .1-mf condenser to stator of tuning gang.	455 kc	BC	1700 kc	Adjust each trimmer, in order, for maximum output. Do not repeat adjustments.	C403A C402A TC402A C401A C400A TC400A
2	Loosely coupled with loop. See Note below.	15 mc	SW	15 mc	Adjust for maximum output. Check for image at 14.1 mc.	C502C
3	Same as Step 2.	15 mc	SW	15 mc	Adjust for maximum output (rock tuning control).	C503
4	Same as Step 2.	1700 kc	BC	1700 kc	Adjust for maximum output.	C502B
5	Same as Step 2.	1500 kc	BC	1200 kc	Adjust for maximum output.	C502A
6	Same as Step 2.	580 kc	BC	580 kc	Adjust for maximum output (rock tuning control).	C520
7	Repeat steps 4, 5, and 6 in order until no further increase in output is noted. Then repeat Step 4.					

Note: Make up a six-to-eight-turn, 6-inch-diameter loop using insulated wire; connect to the signal-generator leads and place near the radio loop.

Figure 12. Chassis view, showing trimmer locations.

FM ALIGNMENT CHART

SIGNAL GENERATOR			RADIO		
Step	Connections To Radio	Dial Setting	Dial Setting	Special Instructions	Adjust Trimmer
1	To terminal 3 of L501B (Figure 10).	9.1 mc (Mod. on).	Gang fully closed.	Connect jumper between pin No. 2 of FM1000 tube and chassis (Note 1). Connect loading network (Note 2) between top of paddler C403B and chassis (Note 3).	C403C
2	Same	Same	Same	Connect loading network between pin No. 2 (blue lead) of third 1:1 tube and chassis.	C403B
3	Same	Same	Same	Connect loading network between pin No. 6 (green lead) of third 1:1 tube and chassis.	C402D
4	Same	Same	Same	Connect loading network between pin No. 2 (blue lead) of second 1:1 tube and chassis.	C402C
5	Same	Same	Same	Connect loading network between pin No. 6 (green lead) of second 1:1 tube and chassis.	C401C
6	Same	Same	Same	Connect loading network between pin No. 2 (blue lead) of first 1:1 tube and chassis.	C401B
7	Same	Same	Same	Leave loading network connected as in step 6.	C400C C400D
8	To grid (pin No. 6) of third 1:1 amplifier tube.	9.1 mc (Mod. off).	Same	Remove loading network, and remove jumper from pin No. 2 of FM1000 tube and chassis. Connect jumper between pin No. 4 (blue lead) of FM1000 tube and junction of R302 and red lead of Z300. Adjust trimmer for zero beat.	C300B
9	Same as step 8.	9.1 mc (Mod. off).	Same	Remove jumper used in step 8. Adjust trimmer for zero beat (SEE NOTE 4).	TC300A
10	To terminal No. 2 of J500 (see Note 5).	105 mc	105 mc	Connect jumper between pin No. 2 of FM1000 tube and chassis. Adjust for maximum output.	C501C
11	Same as step 10.	88 mc	88 mc	Adjust coil L501C for maximum output (Note 6).	C501A
12	Repeat steps 10 and 11 until no further improvement is noted.				
13	Same as step 10.	105 mc	105 mc	Adjust for maximum output (rock tuning control).	C501B
14	See Note 7.	105 mc	105 mc	Adjust for maximum output.	C501A
15	Same as step 14.	92 mc	92 mc	Adjust coil L501B, then L501A, for maximum output.	C501A
16	Repeat steps 13, 14, and 15 until no further improvement in sensitivity can be obtained.				

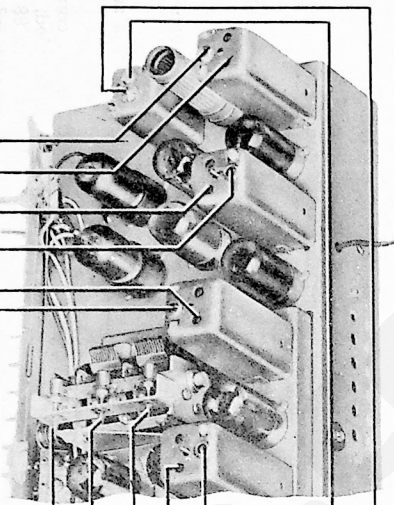

Figure 13. Chassis view, showing FM trimmer locations.

ALIGNMENT OF FM CIRCUITS

Align the AM circuits first.

AM SIGNAL GENERATOR: Connect generator ground lead to radio chassis; connect output lead through a .1-mf condenser to the points specified in the chart.

OUTPUT METER: Connect output meter between terminal No. 3 of the aerial terminal panel and the radio chassis.

CONTROLS: Set treble tone control and volume control fully clockwise; bass tone control fully counterclockwise. Depress FM push button.

LOCATION OF COILS L501A, L501B, L501C: For the location of coils L501A, L501B, L501C, (steps 11 and 15), refer to the base layout of Section 5, figure 11.

ALIGNMENT NOTES

1. When pin No. 2 of the FM1000 tube is connected to the chassis, the detector-oscillator is made inoperative, thereby converting the circuit from an FM to an AM detector.
2. Make the loading network by connecting a 4700-ohm resistor and a .1-mf condenser in series. Attach an alligator clip to each free end of the network. When this network is connected across the primary or secondary winding of an over-coupled i-f transformer, the network loads the circuit so that the transformer is effectively below critical coupling; the unloaded winding may then be correctly peaked at the intermediate frequency.
3. The top of padder C403B can be reached only from the top of the shield can. Slide a length of flattened solder or wire down between the ceramic form and the edge of the trimmer plate. Attach the loading network between this connection and the chassis.
4. It is essential that the output from the generator be kept below the point where the detector-oscillator locks in, otherwise an erroneous zero-beat will be obtained. When a single very sharp zero-beat point is obtained, the adjustment is correct.
5. The adjustments given in steps 10 to 16 are recommended only if the available signal generator is sufficiently accurate to insure correct frequency settings. Otherwise, an alternate procedure employing FM broadcast station signals in place of a signal generator is recommended. For adjustment at the high-frequency end of the band, use the station nearest 105 mc; for the low-frequency adjustments, use the stations nearest 88 mc and 92 mc. If the radio is greatly misaligned, it may be necessary to adjust the padders and coils for maximum noise at each end of the band before station signals can be heard. The FM detector must be made inoperative as given in step 10 of FM circuit alignment.
6. Check all coil adjustments with a tuning wand. If inserting the brass end in or near the coil increases the output-meter reading, spread the turns; if the powdered-iron end increases the output reading, compress the turns. If both ends cause a decrease in output, the coil is correctly tuned. Do not change the coils excessively since only a small adjustment is required at these frequencies.
7. Make two simple dipole aerials to feed signals from the signal generator to the radio. Each dipole aerial may consist of two 30-inch lengths of rubber-covered wire. Connect one dipole aerial to terminals 1 and 2 on the radio FM aerial socket. Connect the other dipole aerial to the output of the signal generator.

SETTING PUSH BUTTONS

1. Connect the output meter between terminal No. 3 on aerial terminal panel and radio chassis.
2. Turn the radio volume control to maximum, and the tone control to its clockwise position.
3. Couple the signal generator loosely through a coil of wire to the radio loop aerial (see Note under ALIGNMENT OF AM CIRCUITS).
4. Turn on the power, and allow the radio to warm up for 15 minutes before starting the adjustments.
5. Starting with the lowest frequency desired, set the signal generator to the desired frequency (modulation on), push the station selector button and adjust the associated oscillator tuning core and aerial trimmer condenser (marked on rear of chassis) for maximum indication on the output meter. Reset the signal-generator frequency, and repeat the procedure for each remaining station selector push button.
6. Turn off the signal generator and make a final adjustment of all tuning cores and trimmer condensers while listening to the stations for which the adjustments are being made.

SECTION 5

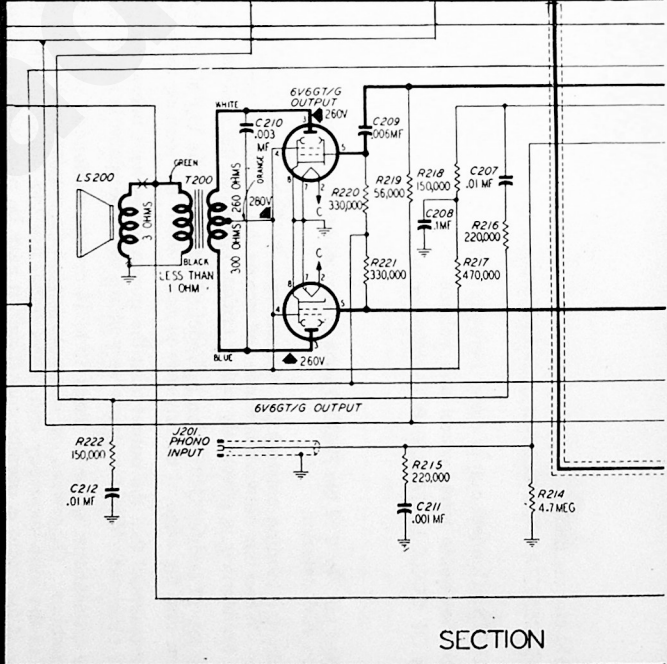
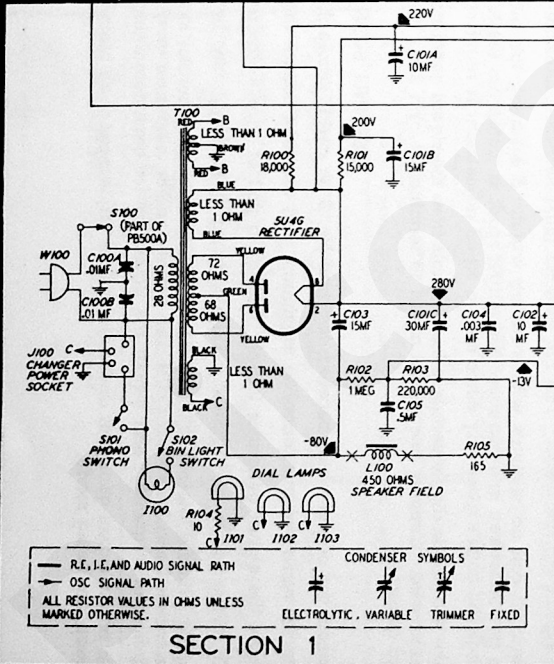
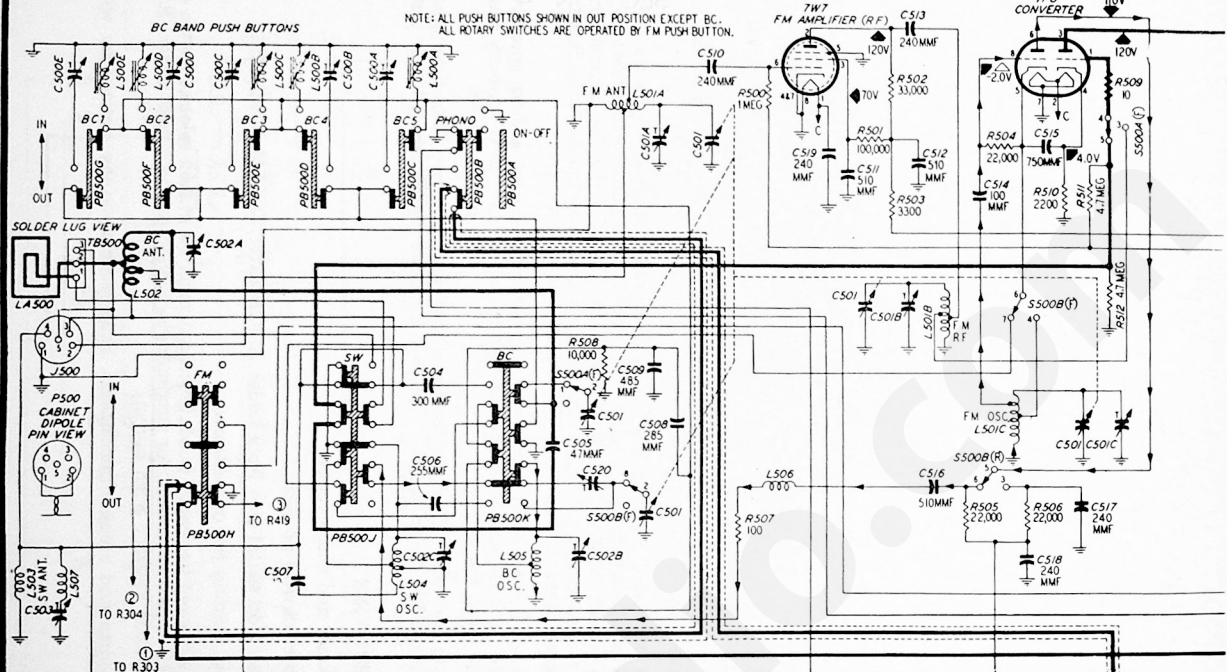

— R.F., I.C., AND AUDIO SIGNAL PATH
 - - - - - OSC. SIGNAL PATH
 ALL RESISTOR VALUES IN OHMS UNLESS MARKED OTHERWISE.

CONDENSER SYMBOLS

ELECTROLYTIC	VARIABLE	TRIMMER	FIXED

Figure 14

NOTE: All voltage, capacity, and resistance values shown are average. The voltages were measured with 117-volt, 60 cycle input

SECTION 4

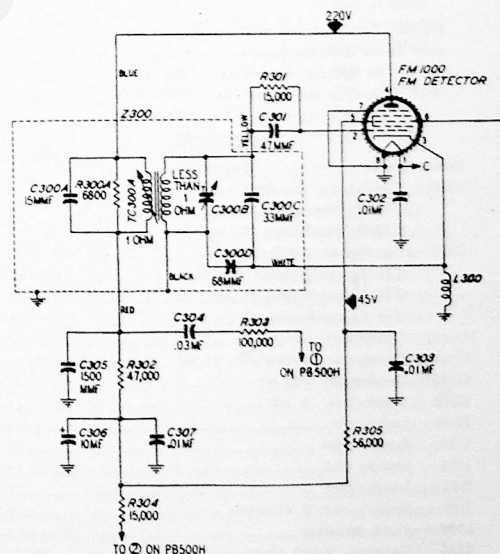
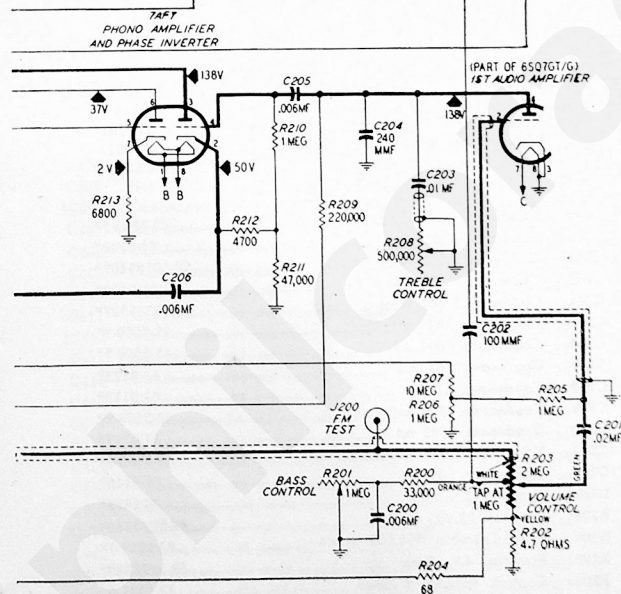
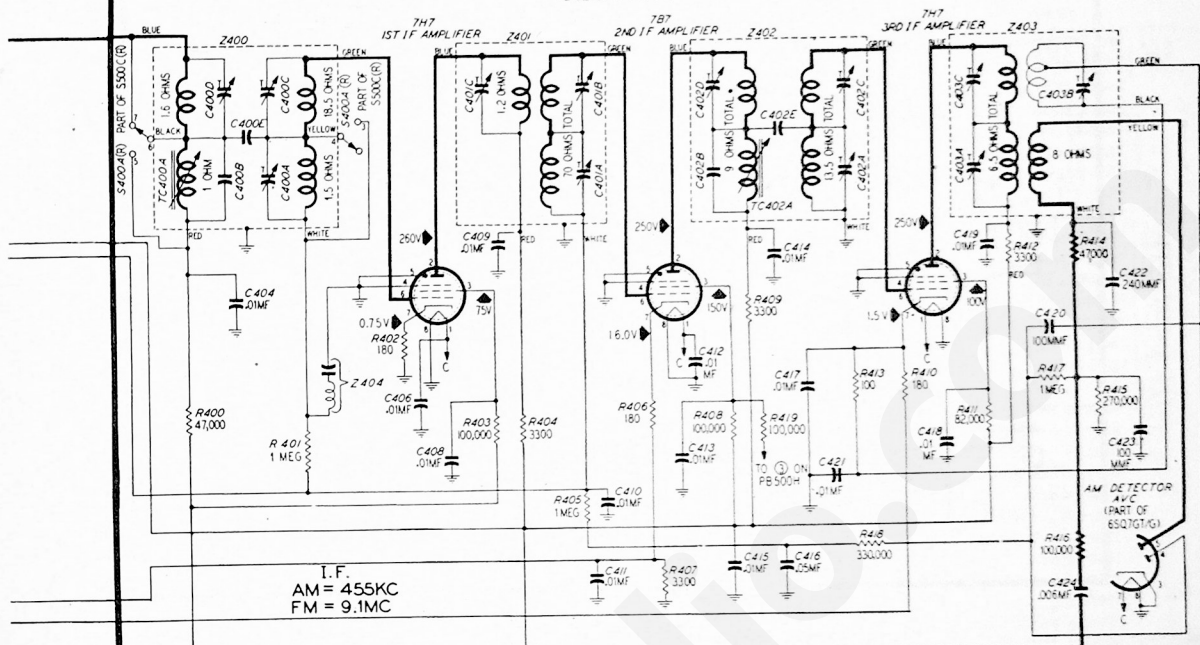

SECTION 3

Complete Schematic.

between the points indicated and the receiver chassis (C), using a 20,000-ohms-per-volt meter, to the receiver power supply.

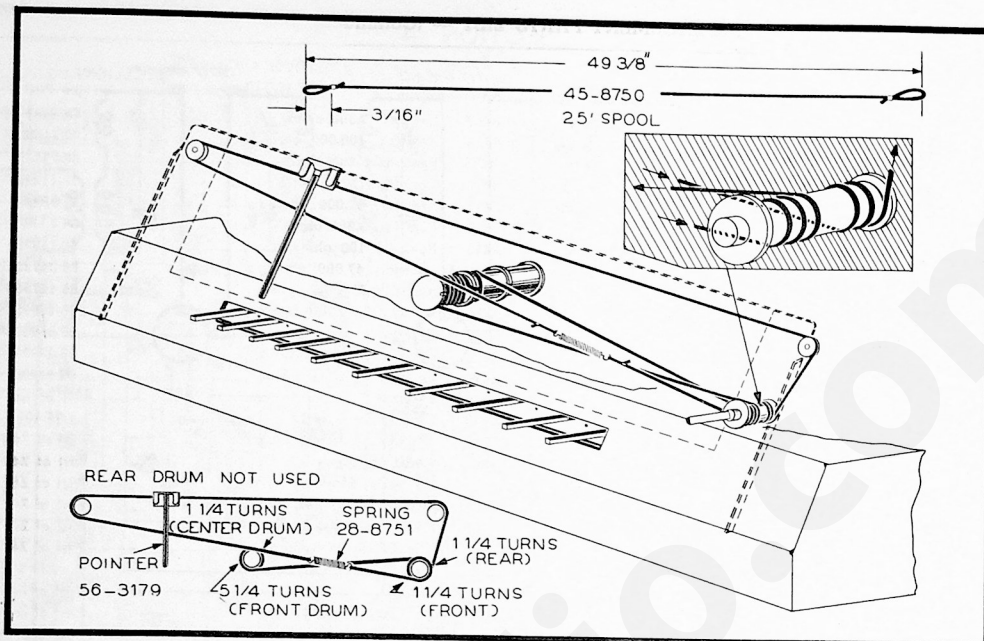

Figure 15. Pointer Drive-Cord Installation Details.

TP-1645

REPLACEMENT PARTS LIST — MODEL 46-1213

NOTE: Parts marked with an asterisk (*) are general replacement items and the numbers may not be identical with those shown on factory assemblies. Use only the "Service Part No." shown in the parts list when ordering replacements.

SECTION 1 (Continued)

Reference No.	Description	Service Part No.
S102	Mercury switch, bin lamp	76-2140-2*
†T100	Transformer, power	32-8282*
T100	Transformer, power, 50 cycles	32-8317
W100	Cord, line	L3199

SECTION 1

Reference No.	Description	Service Part No.
C100	Condenser, line-filter	3903-ODG
	C100A: condenser, .01 mf	Part of C100
	C100B: condenser, .01 mf	Part of C100
C101	Condenser, electrolytic	30-2570-1*
	C101A: condenser, 10 mf	Part of C101
	C101B: condenser, 15 mf	Part of C101
	C101C: condenser, 30 mf	Part of C101
†C102	Condenser, electrolytic, 10 mf	30-2570-2*
C103	Condenser, electrolytic, 15 mf	30-2568-1*
C104	Condenser, .003 mf	61-0117*
C105	Condenser, .5 mf	61-0133*
I100	Lamp, bin	34-2484*
I101	Lamp, pilot	34-2040*
I102	Lamp, dial	34-2040*
I103	Lamp, dial	34-2040*
J100	Socket, record changer	27-6182*
L100	Field, speaker	Part of LS400
R100	Resistor, 18,000 ohms	66-3184340*
R101	Resistor, 15,000 ohms	66-3153340*
R102	Resistor, 1 meg.	66-5103340*
R103	Resistor, 220,000 ohms	66-4223340*
R104	Resistor, 10 ohms	66-0104340*
†R105	Resistor, 185 ohms	33-3435-1*
S100	Switch, ON-OFF	Part of PB500A
S101	Switch, phono	Part of PB500B

SECTION 2

C200	Condenser, .006 mf	45-3500-7*
C201	Condenser, .02 mf	61-0108*
C202	Condenser, 100 mmf	60-10105407*
C203	Condenser, .01 mf	61-0120*
C204	Condenser, 240 mmf	60-10245307*
C205	Condenser, .006 mf	45-3500-7*
C206	Condenser, .006 mf	45-3500-7*
†C207	Condenser, .01 mf	61-0120*
C208	Condenser, .1 mf	61-0113*
C209	Condenser, .006 mf	45-3500-7*
C210	Condenser, .003 mf	61-0117*
C211	Condenser, .001 mf	45-3500-5*
†C212	Condenser, .01 mf	61-0120*
LS200	Speaker	36-1606*
R200	Resistor, 33,000 ohms	66-3333340*
R201	Control, treble, 500,000 ohms	33-5539-7*
R202	Resistor, 4.7 ohms	66-9473340*
R203	Control, volume, 2 megs.	33-5535-5
R204	Resistor, 68 ohms	66-0683340*
R205	Resistor, 1 meg.	66-5103340*
R206	Resistor, 1 meg.	66-5103340*
R207	Resistor, 10 megs.	66-6103340*
R208	Control, bass, 1 megohm	33-5539-8*
R209	Resistor, 220,000 ohms	66-4223340*
R210	Resistor, 1 meg.	66-5103340*

REPLACEMENT PARTS LIST — (Continued)

SECTION 2 (Continued)		
Reference No.	Description	Service Part No.
R211	Resistor, 47,000 ohms	66-3473340*
R212	Resistor, 4,700 ohms	66-2473340*
R213	Resistor, 6,800 ohms	66-2683340*
R214	Resistor, 4.7 megs.	66-9473340*
R215	Resistor, 220,000 ohms	66-4223340*
R216	Resistor, 220,000 ohms	66-4223340*
R217	Resistor, 470,000 ohms	66-4473340*
R218	Resistor, 150,000 ohms	66-4153340*
R219	Resistor, 56,000 ohms	66-3563340*
R220	Resistor, 330,000 ohms	66-4333340*
R221	Resistor, 330,000 ohms	66-4333340*
R222	Resistor, 150,000 ohms	66-4153340*
T200	Transformer, output	32-8274*

SECTION 3

†C301	Condenser, 47 mmf	60-00515307*
†C302	Condenser, .01 mf	61-0120*
C303	Condenser, .01 mf	61-0120*
C304	Condenser, .03 mf	45-3500-1*
C305	Condenser, 1500 mmf	60-20155404*
C306	Condenser, 10 mf	Part of C102
C307	Condenser, .01 mf	61-0120*
L300	Choke	32-3352
R301	Resistor, 15,000 ohms	66-3153340*
R302	Resistor, 47,000 ohms	66-3473340*
R303	Resistor, 100,000 ohms	66-4103340*
R304	Resistor, 15,000 ohms	66-3153340*
R305	Resistor, 56,000 ohms	66-3563340*
Z300	Transformer, FM detector	32-4004
C300A:	condenser, 15 mmf	Part of Z300
C300B:	condenser, trimmer	Part of Z300
C300C:	condenser, 33 mmf	Part of Z300
C300D:	condenser, 68 mmf	Part of Z300
R300A:	resistor, 6.80 ohms	Part of Z300

SECTION 4

C404	Condenser, .01 mf	61-0120*
C405	Not used	
†C406	Condenser, .01 mf	61-0120*
C407	Not used	
C408	Condenser, .01 mf	61-0120*
C409	Condenser, .01 mf	61-0120*
C410	Condenser, .01 mf	61-0120*
C411	Condenser, .01 mf	61-0120*
†C412	Condenser, .01 mf	61-0120*
C413	Condenser, .01 mf	61-0120*
C414	Condenser, .01 mf	61-0120*
C415	Condenser, .01 mf	61-0120*
C416	Condenser, .05 mf	61-0122*
C417	Condenser, .01 mf	61-0120*
C418	Condenser, .01 mf	61-0120*
C419	Condenser, .01 mf	61-0120*
C420	Condenser, 100 mmf	60-10105407*
C421	Condenser, .01 mf	61-0120*
C422	Condenser, 240 mmf	60-10245307*
C423	Condenser, 100 mmf	60-10105407*
C424	Condenser, .006 mf	45-3500-7*
R400	Resistor, 47,000 ohms	66-3473340*
R401	Resistor, 1 meg.	66-5103340*
R402	Resistor, 180 ohms	66-1183340*
R403	Resistor, 100,000 ohms	66-4103340*
R404	Resistor, 3,300 ohms	66-2333340*
R405	Resistor, 1 meg.	66-5103340*
R406	Resistor, 180 ohms	66-1183340*

SECTION 4 (Continued)		
Reference No.	Description	Service Part No.
R407	Resistor, 3,300 ohms	66-2333340*
R408	Resistor, 100,000 ohms	66-4103340*
†R409	Resistor, 3,300 ohms	66-2333340*
R410	Resistor, 180 ohms	66-1183340*
R411	Resistor, 82,000 ohms	66-3823340*
R412	Resistor, 3,300 ohms	66-2333340*
R413	Resistor, 100 ohms	66-1103340*
R414	Resistor, 47,000 ohms	66-3473340*
R415	Resistor, 270,000 ohms	66-4273340*
R416	Resistor, 100,000 ohms	66-4103340*
R417	Resistor, 1 meg.	66-5103340*
R418	Resistor, 330,000 ohms	66-4333340*
R419	Resistor, 100,000 ohms	66-4103340*
S400A(R)	Switch	Part of S500
Z400	Transformer, 1st i-f	32-4020-1*
C400A:	condenser, trimmer	Part of Z400
C400B:	condenser	Part of Z400
C400C:	condenser, trimmer	Part of Z400
C400D:	condenser, trimmer	Part of Z400
C400E:	condenser	Part of Z400
TC400A:	core, tuning	Part of Z400
Z401	Transformer, 2nd i-f	32-4001*
C401A:	condenser, trimmer	Part of Z401
C401B:	condenser, trimmer	Part of Z401
C401C:	condenser, trimmer	Part of Z401
Z402	Transformer, 3rd i-f	32-4002
C402A:	condenser, trimmer	Part of Z402
C402B:	condenser	Part of Z402
C402C:	condenser, trimmer	Part of Z402
C402D:	condenser, trimmer	Part of Z402
†C402E:	condenser, 3.3 mmf	Part of Z402
TC402A:	core, tuning	Part of Z402
†Z403	Transformer, 4th i-f	32-4003-2*
C403A:	condenser, trimmer	Part of Z403
C403B:	condenser, trimmer	Part of Z403
C403C:	condenser, trimmer	Part of Z403
C403D:	condenser, 270 mmf	Part of Z403
Z404	Condenser and choke	38-9851-3

SECTION 5

C501	Condenser, tuning	31-2694-1
C501A:	condenser, FM aerial trimmer	Part of C501
C501B:	condenser, FM converter trimmer	Part of C501
C501C:	condenser, FM oscillator trimmer	Part of C501
C502	Condenser, trimmer assembly	31-6477
C502A:	condenser, shunt trimmer, bc aerial	Part of C502
C502B:	condenser, shunt trimmer, bc osc.	Part of C502
C502C:	condenser, shunt trimmer, s-w osc.	Part of C502
C503	Condenser, shunt trimmer, s-w aerial	31-6473-2
C504	Condenser, 300 mmf	30-1220-10*
†C505	Condenser, 47 mmf	60-00515307*
C506	Condenser, 255 mmf	60-10255237*
C507	Condenser, 10 mmf	60-00105407*
C508	Condenser, 285 mmf	30-1220-9*
C509	Condenser, 485 mmf	30-1220-23*
†C510	Condenser, 240 mmf	60-10245307*
C511	Condenser, 510 mmf	60-10515307*
C512	Condenser, 510 mmf	60-10515307*
†C513	Condenser, 240 mmf	60-10245307*
†C514	Condenser, 100 mmf	60-10105407*
C515	Condenser, 750 mmf	60-10755301*
C516	Condenser, 510 mmf	60-10515307*
†C517	Condenser, 240 mmf	60-10245307*
C518	Condenser, 240 mmf	60-10245307*
†C519	Condenser, 240 mmf	60-10245307*
C520	Condenser, series trimmer, bc osc.	31-6473-3

REPLACEMENT PARTS LIST — (Continued)

SECTION 5 (Continued)

MISCELLANEOUS (Continued)

Reference No.	Description	Service Part No.
J500	Socket, s-w and FM aerial	27-6214*
L501A	Coil, FM aerial	32-3993
L501B	Coil, FM converter grid	32-3992
L501C	Coil, FM oscillator	32-3994
L502	Coil, bc aerial	32-4049-1
L503	Coil, s-w aerial	32-4050-2
L504	Coil, s-w oscillator	32-3996
L505	Coil, bc oscillator	32-4019-1
L506	Choke, r-f	32-4089
L507	Choke, r-f	32-4111
LA500	Loop, bc	76-2262
PB500	Push-button switch, coil, and padder assembly	
	C500: Push-button padder-strip assembly	31-6479
	C500A: condenser	Part of C500
	C500B: condenser	Part of C500
	C500C: condenser	Part of C500
	C500D: condenser	Part of C500
	C500E: condenser	Part of C500
	L500: Push-button coil assembly	
	L500A: coil, push-button (Part of L500)	32-4059
	L500B: coil, push-button (Part of L500)	32-4059
	L500C: coil, push-button (Part of L500)	32-4059-1
	L500D: coil, push-button (Part of L500)	32-4059-1
	L500E: coil, push-button (Part of L500)	32-4059-1
	Switch, push-button assembly	42-1777
R500	Resistor, 1 meg.	66-5103340*
R501	Resistor, 100,000 ohms	66-4103340*
R502	Resistor, 33,000 ohms	66-3333340*
R503	Resistor, 3,300 ohms	66-2333340*
R504	Resistor, 22,000 ohms	66-3223340*
R505	Resistor, 22,000 ohms	66-3223340*
R506	Resistor, 22,000 ohms	66-3223340*
R507	Resistor, 100 ohms	66-1103340*
R508	Resistor, 10,000 ohms	66-3103340*
R509	Resistor, 10 ohms	66-0103340*
R510	Resistor, 2,200 ohms	66-2223340*
R511	Resistor, 4.7 megs.	66-5473340*
R512	Resistor, 4.7 megs.	66-5473340*
S500	Rotary switch, wave (3-section)	76-2211
	S500A: switch section	Part of S500
	S500B: switch section	Part of S500
	S400A: switch section	Part of S500

MISCELLANEOUS

	Description	Service Part No.
Band-Switch Hardware		
	Fulcrum assembly	76-2206
	Fasteners, mounting switch to fulcrum	28-4279FA1
	Link, switch to fulcrum	54-7169
	Screw	1W19644FA3
	Bin-light socket assembly	41-3742-3
	Cabinet 46-1213 M	10656M
	Cabinet 46-1213 L	10656A
	Cabinet 46-1213 W	10656B
Cabinet Parts and Hardware		
	Cabinet top 46-1213W	45-6401
	Baffle and cloth assembly (R.H.) 46-1213 L	40-6795
	Baffle and cloth assembly (L.H.) 46-1213M	40-6784
	Baffle and cloth assembly (L.H.) 46-1213L	40-6796
	Baffle and cloth assembly (R.H.) 46-1213M	40-6785
	Brass pulls 46-1213 L	56-3408
	Baffle, wood	219047
	Bolts, speaker	W1587
	Bullet strike	45-6216
	Bracket and cradle	76-2200
	Bullet catch	45-6215
	Bracket, lamp	56-2332
	Continuous hinge	56-3627
	Dial-scale and backplate assembly	76-2324
	Bin mechanism (L.H.)	76-2368
	Bin Mechanism (R.H.)	76-2174-J
	Doors (set) 46-1213W	45-1555
	Doors (set) 46-1213M	45-1556
	Doors (set) 46-1213L	45-1557
	Nut, speaker	1W19988FA3

	Description	Service Part No.
	Tell-tale jewel	54-4304
	Wire-mesh grille	56-3250
	Brass pulls 46-1213M, 46-1213W	56-3249
	Plastic door pulls, 3/2" mtg. centers 46-1213 M, 46-1213 W	AD-1026
	Domes	45-6042
	Knife hinge	56-4066
	Instrument panel (bezel) 46-1213L	45-6381
	Instrument panel (bezel) 46-1213M	45-6382
	Instrument panel (bezel) 46-1213W	45-6383
	Cable and plug, speaker	41-3734-3
	Speaker-cable plug	27-4419-2*
	Cable assembly, shielded, length 10 5/8"	41-3754-1
	Cable assembly, shielded, length 5 3/4"	41-3754-2
	Cable assembly, shielded, length 8 1/4"	41-3754-3
	Cable assembly, shielded, length 18"	41-3754-4
	Cable and plug, shielded, phono (J201)	41-3735
Chassis Mounting Hardware		
	Bracket support	56-3616FA3
	Lock washer	1W24260FA3
	Nut	1W19994FA3
	Screw, wood	1W25036FA9
	Grommet	54-4122
	Screw, 1/4 x 20 x 7/4	1W17327FA3
	Washer	1W52538FA3
	Clip, bc aerial coil	28-5002FA1
	Clip, bc osc., s-w osc. coils	28-2927FA1
Dial Scale Hardware		
	Backplate assembly	76-2106
	Pulleys	11W29741
	Drive-cord assembly	45-8750
	Studs	1W29824FA5
	Pointer	56-3179
	Shaft, tuning drive	76-2107
	"C" washer, drive-shaft	1W42536FA3
	Spring, drive-cord	28-8751
	Screw, backplate-mounting	1W19670FA3
	Knob, push buttons	54-4292
	Knob, controls	54-4227
	Loop, FM	76-2381-1
Loop Mounting Hardware (Broadcast)		
	Spacer	1W-29184FA3
	Washer, spring	28-4186
	Washer	1W52540FA3
Push-Button-Assembly Hardware		
	A-C switch, cover assembly	76-1343
	Switch, a-c (ON-OFF)	42-1717
	Switch, PHONO	42-1714
	Cap, push-button	54-4294
	Cup, tuning-core	28-6996
	Grommet, rubber, mounting	27-4596
	Screw, mounting	1W19674FA3
	Screw, tuning-core	56-2249
	Tab, off	54-4317
	Tab, phono	54-4321
	Tab, broadcast	54-4318
	Tab, shortwave	54-4319
	Tab, FM	54-4320
	Tuning core	56-6100
	Terminal strip, coils	56-2250FA3
	Plug, FM loop	54-4346
R-F Unit Mounting Hardware		
	Grommet	54-4295
	Screw	1W-19674FA3
	Spacer	1W29155FA3
	Washer	1W52224FA3
	Socket assembly, dial-light	76-2109
	Socket assembly, dial-light (7" lead)	76-2109-2
	Socket assembly, pilot	41-3737
	Socket, 5-prong, external aerial	27-6214*
	Socket, Loktal, r-f unit	27-6213*
	Socket, Loktal, main chassis	27-6138*
	Socket, octal	27-6199*
	Socket, phono-power	27-6182*
	Socket, single-prong (FM test)	27-6180*
	Tube shield (FM1000)	56-2731
Changer Mounting Hardware		
	Spring	56-3043
	Bolt	56-3295
	Grommet	54-4313
	"T" Nut	1W56643FA3
	Palnut	1W29061FA3
	Input transformer	32-8256
	FM loop assembly, cabinet	76-2391-1
	Back assembly, cabinet	40-6840
	Fasteners, back-assembly	W2235FA9
	Drive-cord kit	45-1459*

PRODUCTION CHANGES FOR MODEL 46-1213

CODE 121 (MAIN CHASSIS)

RUN 2

- a. Physical wiring changes were made.
- b. Condenser C207, .01 mf., 600v, Part No. 30-4501, was changed to .003 mf., 100v, Part No. 61-0117*.
- c. Condenser C212 was removed.
- d. Resistor R222, 150,000 ohms, Part No. 66-4153340*, was changed to 470,000 ohms, Part No. 66-4473340*.

RUN 3

Condenser C505, 47mmf., Part No. 60-00515307*, was changed to 22mmf., Part No. 60-00205307*.

RUN 4

Condenser C207 (changed to .003 mf., Part No. 61-0117*, in Run 2) was changed to .006 mf., Part No. 45-3500-7*.

RUN 5

- a. The 4th i-f transformer, Z403, Part No. 32-4003, was replaced by Part No. 32-4003-2.
- b. Resistor R409, 3300 ohms, Part No. 66-2333340*, was changed to 1500 ohms, Part No. 66-2153340*.

RUN 6

A few sets were produced using Part No. 32-4003 4th i-f transformer and 3300-ohm R409 resistor, as used before the changes described for Run 5. After the production of these few sets, the above parts were again replaced by those used in Run 5.

RUN 7

- a. In the sets produced at the start of this run, a 22-ohm resistor, Part No. 66-0223340*, was added, in series with the control grid of the FM1000 tube.
- b. The 22-ohm resistor added in a. (above) was replaced by a 27-ohm resistor, Part No. 66-0273340*.
- c. A 240-mmf. condenser, Part No. 60-10245307*, was added, between contact No. 10 and contact No. 8 (ground) on the FM push-button switch.
- d. A 22-mmf. condenser, Part No. 60-00205307*, was added, between contact No. 8 of the PHONO push button and ground.
- e. Physical wiring changes were made.

RUN 8

- a. A .01-mf., 600v condenser, Part No. 61-0120*, was added, from the junction of R406 and R407 to ground.

RUN 9

A 220-mmf. condenser, Part No. 60-10225307*, was added, between contact No. 14 of the FM push-button switch and ground.

RUN 10

Resistor R105, 165 ohms, Part No. 33-3435-1*, was removed.

NOTE: All sets up to, and including, Run 9 used power transformer Part No. 32-8282 with the yellow dab, and the 165-ohm resistor (R105) for additional power-tube bias, as described under GENERAL INFORMATION.

RUN 11

- a. The 110-volt bin lamp, Part No. 34-2484*, was replaced by a 6-volt lamp, Part No. 34-2039*.
- b. The bin-lamp cable-and-switch assembly, Part No. 41-3742-3, was changed to Part No. 76-2746.

RUN 12

Condenser C301, 47 mmf., Part No. 60-00515307*, was changed to 33mmf., Part No. 60-00305307*.

RUN 13

Electrolytic condenser C102, 10—10mf., 450v, Part No. 30-2570-2*, was changed to 10—15 mf., 450v, Part No. 30-2552*.

RUN 14

The power transformer (T100), Part No. 32-8282*, was changed to Part No. 32-8286*.

NOTE: In the sets using this transformer, a 200-ohm, 25-watt resistor, Part No. 45-4000-8, is connected between the filament of the rectifier tube (5U4G) and the first electrolytic condenser, C103. If the transformer is replaced by Part No. 32-8282, the 200-ohm resistor should be removed, and a jumper connected in its place. If the Part No. 32-8282 transformer is marked with a yellow dab, a 165-ohm resistor should be connected in series with the speaker field, as described under GENERAL INFORMATION.

CODE 121 (R-F CHASSIS)

NOTE: All details of Section 5 (r-f circuits) in the original manual apply to Run 6.

RUN 2

- a. Resistor R506 used in this run was 4700 ohms, Part No. 66-2473340*.
- b. Condenser C519, 240 mmf., Part No. 60-10245307*, shown in the schematic between pin 1 of the 7W7 r-f tube and ground, was not used in this run.

RUN 3

Physical wiring changes were made.

RUN 4

Condenser C514 used in this run was 240 mmf., Part No. 60-10245307*.

RUN 5

Physical wiring changes were made.

RUN 6

The .01-mf. condenser, Part No. 61-0120*, at the grid return lead of the 1st i-f transformer, was replaced by the condenser-and-choke assembly, Z404, Part No. 38-9851-3.

NOTE: All details of Section 5 (r-f circuits) in the original manual apply to this run.

RUN 7

a. Condenser C510 was replaced by a 10-mmf. condenser, Part No. 60-00105407*, which was connected to the high-potential end of L501A (at the point where C501A is connected) instead of the tap.

b. Condenser C513 was replaced by a 47-mmf. condenser, Part No. 66-00515307*, which was connected to the high-potential end of L501B (at the point where C501C is connected) instead of the tap.

RUN 8

a. The condenser-and-choke assembly, Z404, was replaced by a .01-mf. condenser, Part No. 61-0120*.

b. The following changes, shown in the accompanying schematic, were also made:

The grounded end of condenser C517 was removed and connected to the high-potential tap on L501C.

The terminal of condenser C514 which was connected to the high-potential tap on L501C was removed and connected to ground.

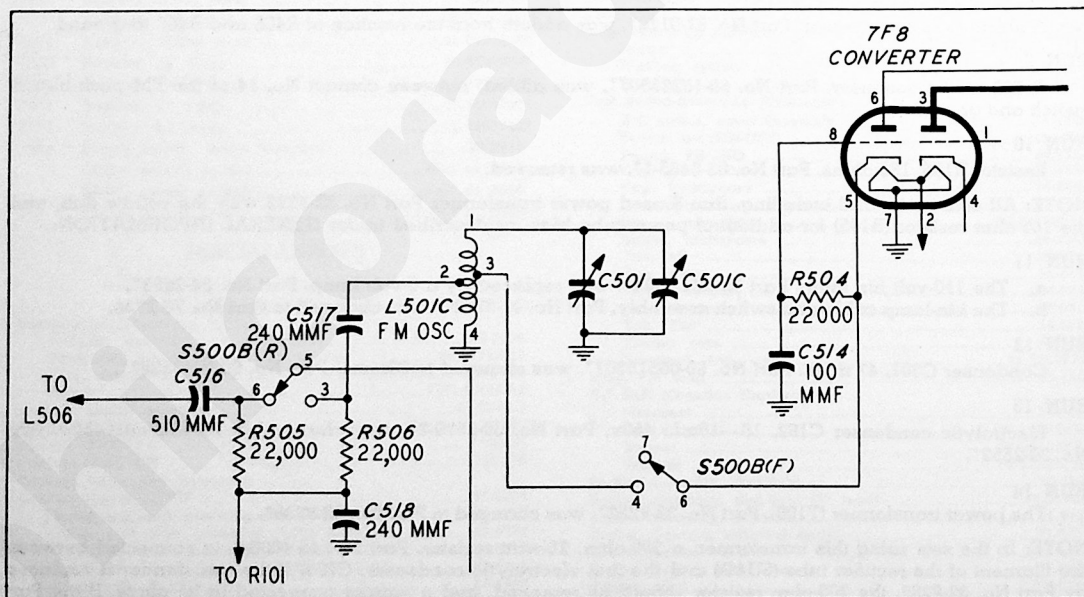

Changes in Section 5, Model 46-1213.

RUN 9

A 220-mmf. condenser, Part No. 60-10225307*, was connected in parallel with condenser C518.

RUN 10

In this run, the .01-mf. condenser, Part No. 61-0120*, was used instead of the condenser-and-choke assembly, Z404.

RUNS 11 and 12

The .01-mf. condenser referred to in Run 10 (above) was replaced by the condenser-and-choke assembly, Z404.

RUN 13

The following heater by-pass changes were made:

- a. Condenser C406 (7H7 1st i.f.), .01 mf., Part No. 61-0120*, was changed to .006mf., Part No. 45-3500-7*.
- b. Condenser C412 (7B7 2nd i.f.), .01 mf., Part No. 61-0120*, was changed to .006 mf., Part No. 45-3500-7*.
- c. A .006-mf. condenser, Part No. 45-3500-7*, was added, between pin 1 of the 7H7 3rd i-f tube and ground.
- d. Condenser C302 (FM1000 det.), .01 mf., Part No. 61-0120*, was changed to .006 mf., Part No. 45-3500-7*.

GENERAL INFORMATION ON MODEL 46-1213

HETERODYNE WHISTLES

In sets using Part No. 32-4003 for the 4th i-f transformer, whistles may occur at the second and third harmonics of the AM i.f. (910 kc. and 1365 kc.). If troublesome, the interference can be eliminated by removing this transformer and replacing it with Part No. 32-4003-2.

POOR SENSITIVITY, EXCESSIVE NOISE, DEAD SET

A leakage or short in the 3.3-mmf. ceramic coupling condenser, C402E, in the 3rd i-f transformer, may cause poor sensitivity, excessive noise, or complete loss of reception. The condenser may be replaced by a 3.3-mmf. condenser, Part No. 30-1224-30.

POWER TRANSFORMERS

1. PART No. 32-8282

Some of the Part No. 32-8282 power transformers have a dab of yellow paint on the side. Those transformers so identified have higher voltage output from the high-voltage winding. Sets using these transformers have a 165-ohm resistor (R105) in series with the speaker field, to provide additional bias voltage for the output tubes. This type of transformer was used in all sets up to, and including, Run 9. When replacing a transformer of this type with a regular Part No. 32-8282 transformer (without the yellow dab), short out the 165-ohm resistor.

2. PART No. 32-8286

A limited number of sets in Run 14 used a Part No. 32-8286 power transformer in place of Part No. 32-8282. In these sets, a 200-ohm, 25-watt resistor (Part No. 45-4000-8*) is connected between the filament of the rectifier tube (5U4G) and the first electrolytic condenser. If this transformer is replaced with Part No. 32-8282, the resistor should be removed and a jumper wire connected in its place.

ROTARY-SWITCH LINK

If the fibre driving link, between the FM push button and the rotary switch, becomes disconnected because the snap fastener falls out, the trouble may be corrected by inserting a taper-pointed tool through the fastener and spreading the prongs.

CRITICAL LEAD DRESS AND PARTS PLACEMENT FOR MODEL 46-1213

1. Choke L506 should be dressed under the filament lead of the r-f unit.
2. The leads of the 1st i-f transformer, Z400, should be dressed away from the 7F8 socket.
3. All leads and lugs of the push-button assembly, PB500, should be dressed under the assembly, to prevent the push buttons from sticking.
4. The leads of i-f transformers Z401, Z402, and Z403 should be dressed along the chassis.