

# PHILCO SERVICEMAN

Copyright 1937 By Philco Radio & Television Corporation



RADIO · MANUFACTURERS · SERVICE · NEWS



AUGUST, 1937

## EDITORIAL

### Correct Installations Pay Dealer Profits

IN past years there has been a tendency on the part of many radio dealers to make customer installations in a hasty, slipshod manner, presumably to "cut down overhead." Once the radio set sale was made, all subsequent expense was to be avoided.

We have always insisted that such a policy is short-sighted, because slipshod installations usually cause unsatisfactory performance, a dissatisfied customer and loss of possible additional sales.

This season you have a plan, all prepared and ready to use. The PHILCO Guarantee Plan, available to all approved and equipped PHILCO dealer-members, costs the customer only \$7.50. When you show him the many benefits he derives from the plan in ADDITION to a high-class aerial installation, few if any customers will hesitate to accept it.

The Guarantee Plan assures the customer of a careful installation, instruction and follow-ups to insure satisfaction. And it assures you of (1) Correct performance, (2) A satisfied customer, (3) Repeat sales to the satisfied customer's friends and neighbors.

If you have not as yet done so, be sure to see your distributor at once about the plan. His service manager or salesman will gladly go over the details with you.

## NEW PHILCO POWER OUTPUT CIRCUIT DESCRIBED

### Degeneration Feature Balances Out Distortion

ONE of the new developments to be found in the new 1938 PHILCO line is the use of degenerative circuits in the output system. These circuits are used to minimize distortion in high-power output stages and also to stabilize the output system.

The circuit diagram of the audio amplifier of the new 38-116 is shown in the figure below. Many of the elements not essential to the functioning of the degenerative circuits have been omitted. For simplicity, batteries have been shown instead of the actual power supply and filter circuits employed in the receiver. While, of course, the circuits differ between different models, this particular one may be considered typical of degenerative circuits in general as applied to PHILCO radio receivers.

#### Distortion Signal Reversed

As distinguished from conventional radio practice, degenerative circuits can best be understood by considering, first, the output signal of the degenerated amplifier and then figuring back to determine the input signal required to produce such an output signal.

This, of course, is the opposite of the customary practice of determining what the output signal will be by consideration of the form of the input signal. Hence, starting with the output transformer, we may assume that there is in the output circuit a signal made up of a desired part and a small distortion signal. Going back to the input of the tube, we find that in order to obtain such an output signal it is necessary to provide the desired signal reduced in size by the amplification of the stage and also some reversed distortion signal. The distortion signal must be reversed because the actual amount of distortion found in the output is considerably less than that which would be present if the amplifier were not degenerated. The reduction in distortion, of course, is the primary purpose of the degenerative circuit.

#### Distortion Bucked Out

A reversed distortion signal is obtained by providing a circuit which compares a portion of the output signal with the input signal. Referring to the diagram, there is a voltage-dividing resistance network connected between the plate of the output tube and the grounded bias point, and the grid or input element of the tube is

(Continued on Page 4)

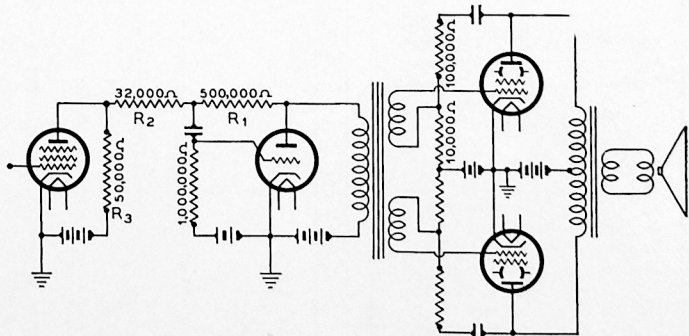

Essential Audio Circuit, PHILCO 38-116X

## SPEEDING UP STATION SETTING

A FAST method for setting up stations on cone-centric tuning models has been suggested to us by W. B. Jones, Service Manager for Columbia Wholesalers, PHILCO distributors in Washington, D. C.

After connecting the 077 Station Setter to the radio set and placing both the set and the signal generator in operation at the correct frequencies, Mr. Jones then proceeds to bring around the cones, starting with the highest frequency first, to the approximate position for the station. After rapidly swinging all cones to their approximate position in this manner, he then tunes back to the highest frequency station and makes his careful adjustments of the vernier tuning to obtain the zero beat from the signal generator, and then tightens up the cones at this final accurately tuned position.

This method of adjusting the cones for the various stations is no different from the standard except that all stations are first set approximately, and then the careful tuning through the aid of the signal generator follows. Mr. Jones claims that he can set up the stations in this manner in about half the time because it is much easier and faster to locate the cones initially.

### 109 PAGES!

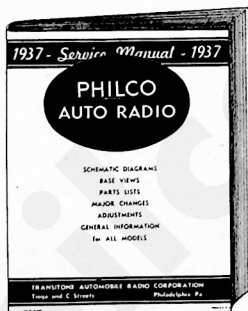

THE new 109-page Transistor Wiring Diagram Book has just come off the press. This manual contains wiring diagrams, parts layouts and adjusting instructions for every model PHILCO automobile radio which has been built to date. Every serviceman who has occasion to work on automobile radios will want to get a copy of this helpful new book at once.

See your PHILCO distributor for your copy.

## Metal "Strong Box" for Radio Parts

AN ATTRACTIVE and sturdy new metal parts cabinet has been made available by PHILCO for PHILCO dealers and servicemen.

This cabinet, designed primarily to hold small parts, contains two drawers, in each of which are separators and adjustable slots. As many as twenty-five individual compartments can be made in each drawer.



These compartments can be adjusted to any desired size up to a maximum of 11½ inches, the depth of the drawer. The overall dimensions of the cabinet are 7½ inches high, 11½ inches deep and 19 inches wide. The cabinet is finished in blue crackle with the wording "Genuine PHILCO Parts" in yellow. The construction is of heavy sheet steel, strongly welded at all joints. On the top of the cabinet, near the front, is a small depression in the metal. The bottom of the cabinet has a similar depression, making it possible to stack two cabinet sections together to form one sturdy group of four drawers. As many additional sections of two drawers each can be stacked in this manner as desired.

Your PHILCO distributor has a special on these cabinets, and we suggest that you make inquiries at once while the supply lasts.

## DOUBLE CHECK FOR POWER OUTPUT TUBES

WHEN testing power output tubes, a supplementary test for emission is sometimes of value in checking certain types of defects. Because of its inherent flexibility, the PHILCO 066 Tube Tester is adapted for an emission test of power output tubes in addition to the usual tests listed in the charts accompanying the tester. These emission tests can be made by using the control settings listed in the following tabulation.

TYPE	FIL. V.	TOGGLE SWITCH	CONTROL 2	SOCKET	SELECTOR
1E7G	2	R	70 0	H	10
1J6G	2	R	28 0	H	10
2A3	2.5	R	80 20	D	4
2A5	2.5	R	84 0	F	8
6A3	6.3	R	79 0	D	4
6A5G	6.3	R	79 0	H	8
6B1G	6.3	R	75 30	H	8
6P6	6.3	R	70 30	H	8
6P6G	6.3	R	70 30	H	8
6L6	6.3	R	75 0	H	8
6L6G	6.3	R	75 0	H	8
'10	7.5	R	58 30	D	4
'12A	5	R	70 0	D	4
19	2	R	70 35	F	10
25A6	25	R	50 20	F	10
25A6G	25	R	20 0	H	13
25B6	25	R	82 0	H	13
25B6G	25	R	82 0	H	8
25L6	25	R	80 0	H	8
25L6G	25	R	80 0	H	8
33	2	R	80 0	H	8
41	6.3	R	70 35	F	12
42	6.3	R	70 5	F	12
43	25	R	80 30	F	12
45	2.5	R	75 30	F	4
46	2.5	R	70 10	E	4
47	2.5	R	70 10	E	4
48	25	R	80 60	F	12
49	2	R	70 40	E	4
50	7.5	R	70 60	D	4
53	2.5	R	20 0	G	12
59	2.5	R	72 20	G	4
71A	5	R	75 60	D	4
1A2B	5	R	70 40	D	2
183	5	R	80 0	D	8

# NEW PARTS ITEMS ANNOUNCED

## Serviceman and Dealer Specialties

A NUMBER of new specialty items will be of great interest to every PHILCO dealer and serviceman.

The first of these is the new PHILCO Speaker-Phone Control Unit. When connected to any radio this new adaptor device permits the use of headphones or extension speaker, either independently of or along with the speaker in the radio. A four-position switch on the unit allows the selection of phones, extension speaker or set speaker or any desired combination of



PHILCO Speaker-Phone Control Unit

these. An extremely desirable feature of the unit is the controllable head-phone volume—an ideal arrangement where one member of the household is hard-of-hearing or for late DXing without disturbing the family. The extension speaker connection is suitable for any standard extension speaker. It is highly desirable for summer use—on the porch, in the garden, in the playground or in the sickroom; especially desirable for hotels, restaurants, cafes and institutions. The part number of the PHILCO Speaker-Phone Control is No. 45-2483, list price \$6.00, subject to regular parts discount.

A new special screw driver is now available for use on the new screws with the cross-type slot. The part number is No. 45-2522, and the list price is \$—, subject to regular parts discount.



Special Screw Driver

An extremely handy device for the serviceman is the new PHILCO Inspection Mirror, which is used for inspecting the chassis in comparatively inaccessible places. This handy item is known as Part No. 45-2474 and sells at a list price of 60 cents, subject to regular parts discount.

The PHILCO Furniture Polish Display Merchandiser will be a highly desirable item for every PHILCO dealer's counter. This display contains six bottles of the famous PHILCO Furniture Polish designed especially for radio cabinets. The list price of the display complete with six bottles of polish is \$3.60, subject to regular parts discount. The part number is No. 45-1321.



PHILCO Furniture Polish Display Merchandiser

Similar to its popular predecessor, the PHILCO Home Radio Pilot Lamp Display, is the new PHILCO Auto Radio Pilot Lamp Display Merchandiser. This new display unit contains eighty-four auto radio pilot lights with an adequate assortment to take care of all types of auto radio requirements. The part number is No. 45-1322. The list price is \$8, subject to regular parts discount.



Inspection Mirror

## Operating Hints for Sky-charger Power Supply

THERE are several precautions which should be observed in the operation of battery receivers equipped with the sky charger power supply. Although most of these points are covered in the instructions accompanying the chargers, we take this opportunity of again calling attention to certain important features.

When a radio set with non-heater type tubes is being operated, the sky charger must positively be disconnected from the receiver. If this point is not carefully observed, the tubes in the radio set will either be burned out or paralyzed because of the extremely high voltage which is delivered by the charger. On a 6-volt output, for example, the line voltage when the charger is running is approximately 8 volts, and this, of course, is sufficient to burn out the tubes within a short time. On receivers equipped with heater-type tube, such as PHILCO Models 38-35 and 38-40, the sky charger may be connected to the battery while receiver is being operated.

Another point which should be carefully observed when operating the radio is to make sure that the charger is turned up so that the edge of the propeller is against the wind and the generator is not running. Connections should also be made through a switch so that the generator can be grounded when not in use, and thus prevent any possibility of high voltage building up and causing tube burnout.

On the 6-volt sets equipped with vibrator it is not practical to operate the radio at a great distance from the batteries. In fact, the practical limit of the "A" battery cable length is that supplied with the radio set. In some installations of the sky charger the power from a bank of batteries is used for lights as well as for radio. Usually in such cases the batteries are installed in an upper floor of the building near the charger. For radio operation, a separate battery should be located at the radio set.

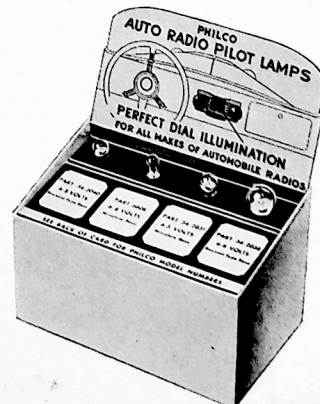

Auto Radio Pilot Lamp Display Merchandiser

## Questions & Answers

1. Q. How can a more pronounced middle point or manual tuning position be obtained on the tuning plunger of the new cone-centric tuning models?

A. On these new models, when it is desired to operate with manual tuning, it is only necessary to depress the tuning plunger slightly until a slight click is heard, at which point the set can be tuned in the usual manner. A more definite and a more pronounced point at which this click is felt can be obtained simply by turning in the adjusting screw on the back of the plunger assembly. The end of this screw bears against a spiral spring on the inside of the assembly, and the spring regulates the pressure against the side of the plunger shaft.

2. Q. When using the Model 077 All-Wave Signal Generator, why is the output meter reading comparatively lower?

A. The Model 077 has a lower percentage of modulation than the average signal generator on the market. By decreasing the percentage of modulation in this way and by increasing the overall R.F. output, far greater stability is obtained. The Model 077 has considerably more R.F. output than other service signal generators. This fact can readily be demonstrated by connecting the 077 to a radio set with shadow tuning and comparing the width of shadow when the set is tuned to the 077 signal with the shadow width when the set is tuned to some other signal generator. It will be noted in each case that the 077 output is considerably higher as indicated by the narrow shadow on the shadowmeter. When the signal is measured on an output meter, however, the meter reading will be slightly lower than it would be on other signal generators having an extremely high percentage of modulation. Of course, it is the R.F. output that is important, and the 077 has about three times as much as most other signal generators.

3. Q. When using the 077 on A.C.-D.C. sets what can be done to eliminate the hum which is sometimes set up?

A. This can be done by disconnecting the line filter condenser across the power line in the 077.

4. Q. What is the cause of concentric dials being off calibration in one direction over the entire dial?

A. This is usually caused by a slightly oversized slot at the top of the dial and the dial, when installed, being turned all the way over to one side of the slot. Care should be observed when installing the dial to make sure that the slot is properly centered.

## New Philco Power Output Circuit

(Continued From Page 1)

connected to this voltage-dividing network through the secondary of the interstage coupling transformer. Between ground and the tapped point of the voltage divider there will be built up a signal proportional to the output signal, but, of course, smaller in magnitude. This signal will include the desired signal and also the distortion signal, and it is reversed with respect to the input signal, due to the operation of the tube. To this signal is added the signal normally supplied to the tube input. The signal on the grid of the tube will then be the signal from the transformer, to the extent that it exceeds the signal fed back, plus the reversed distortion signal, and this signal, as it proceeds through the amplifier, is, of course, distorted by the amplifier, but the distortion is in such a direction as to buck out the distortion fed back to the input circuit, thus producing a less distorted output signal.

In the design of such circuits the usual practice is to set the limits as to the amount of distortion which can be tolerated, select a sufficient portion of reversed distortion signal in the feedback circuit so as not to exceed this distortion level and then add a sufficient amount of the input signal to give the desired amount of output. In this way the circuit operates to overcome the inherent distortion in the amplifier itself.

### Output Impedance Lowered

It is interesting to consider also what would happen if there were a signal in the output circuit, but no input signal. In this case the feedback circuit would again supply a reversed signal, but there being no input signal, this portion of the output signal would be supplied to the grid of the circuit in such a direction as to cause the amplifier to form another signal in the output circuit which would oppose the first signal. As will be apparent, this effect is much the same as providing a load on the output circuit, and the signal is rapidly suppressed, as it would be if the impedance of the tube were lower. This is a very desirable

effect, as it reduces the impedance into which the loud speaker works and thus tends to prevent the loud speaker from continuing to produce sounds after the input signal is cut off.

### Driver Stage Similar

In the output stage the signal fed back and the incoming signal have been directly superimposed. In the driver stage similar results are obtained by a slightly different voltage-combining network. If the tube on the left of the figure is considered to be a resistance, it will be seen that the feedback circuit is made up of resistances  $R_1$ ,  $R_2$  and  $R_3$  in shunt with the tube, and hence there will be impressed upon the grid of the tube, due to this network, a portion of the reversed output signal, including whatever distortion may be present in it. Likewise, considering the driver tube as a resistance and the first tube as a voltage source, there will be supplied to the grid of the tube a desired signal obtained across part of the voltage divider, including the resistance  $R_2$  in series with the combined resistance of the grid leak  $R_1$  and the tube. Due to the relative magnitudes of the several resistors in this latter case, substantially all of the signal from the voltage amplifier tube will be supplied to the grid of the driver tube, hence this circuit will operate in the same manner as that described above.

### Gain Lowered

It will be observed that whenever degeneration is employed the gain of the stage is reduced, and this sacrifice must be made in order to minimize distortion. In fact, roughly speaking, the decrease in distortion is about inversely proportional to the decrease in stage gain. For example, if a stage has a gain of 20 with 10 per cent distortion, this distortion may be reduced to 2 per cent for the same output power by reducing the gain to 4. While this, of course, is a disadvantage, it is more than compensated for by the improved performance and freedom from distortion which obtains as a result of the use of these circuits.