

THE SUPER
HIGH FIDELITY

PHILCO



*P*HILCO announces the 680X

—latest and greatest addition to the musical instruments of quality for which it has become nationally and internationally famous. Simultaneously, Philco takes another step forward in broadening its service to the public by placing the facilities of The Radio Institute of the Audible Arts at the command of every 680X owner.

- The Radio Institute of the Audible Arts, which was founded by Philco as a public service contribution to the radio listeners of America is under the direction of Pitts Sanborn, noted music critic and program annotator, together with an Advisory Committee of leaders in the fields of music, education, entertainment and the dissemination of public opinion.
- Through correspondence with thousands of educators, music groups, rural leaders, other individuals and organizations, the Institute has become a clearing house for information and is stimulating the appreciation of better programs.
- It has inaugurated a monthly bulletin service of recommended radio programs such as music, informative talks and entertainment. In addition, booklets, manuals and lectures, covering many subjects allied to radio, including music, listening groups and children's programs, have been written by leading authorities, many of them members of the Institute's Advisory Committee.
- These publications, together with the monthly program bulletin service, are available to 680X owners and may be obtained by writing to The Radio Institute of the Audible Arts, 80 Broadway, New York City. Purchasers of the 680X are particularly invited to utilize the Institute's facilities for supplying information on any phase of the broad field of radio, so that they may enjoy to the fullest degree the many splendid programs on the air.

Philco 680X

THE SUPER HIGH-FIDELITY RADIO

*F*or those discriminating listeners who demand the utmost in radio performance and tonal fidelity, the Philco Engineering Laboratories have designed and perfected Philco 680X . . . the finest radio in all the world today.

- Drawing upon the store of scientific knowledge derived from their experience in building over six million radios, Philco engineers designed the 680X without the slightest regard to ordinary commercial limitations. Their only objective was to produce a radio incorporating every advance in the twin sciences of radio reception and acoustic fidelity.

- This booklet tells the story of the 680X as completely yet as concisely as type and illustrations will permit. But to arrive at a true appraisal of the outstanding quality of the 680X, may we suggest that you visit your Philco dealer and spend some delightful moments listening to this superb musical instrument.

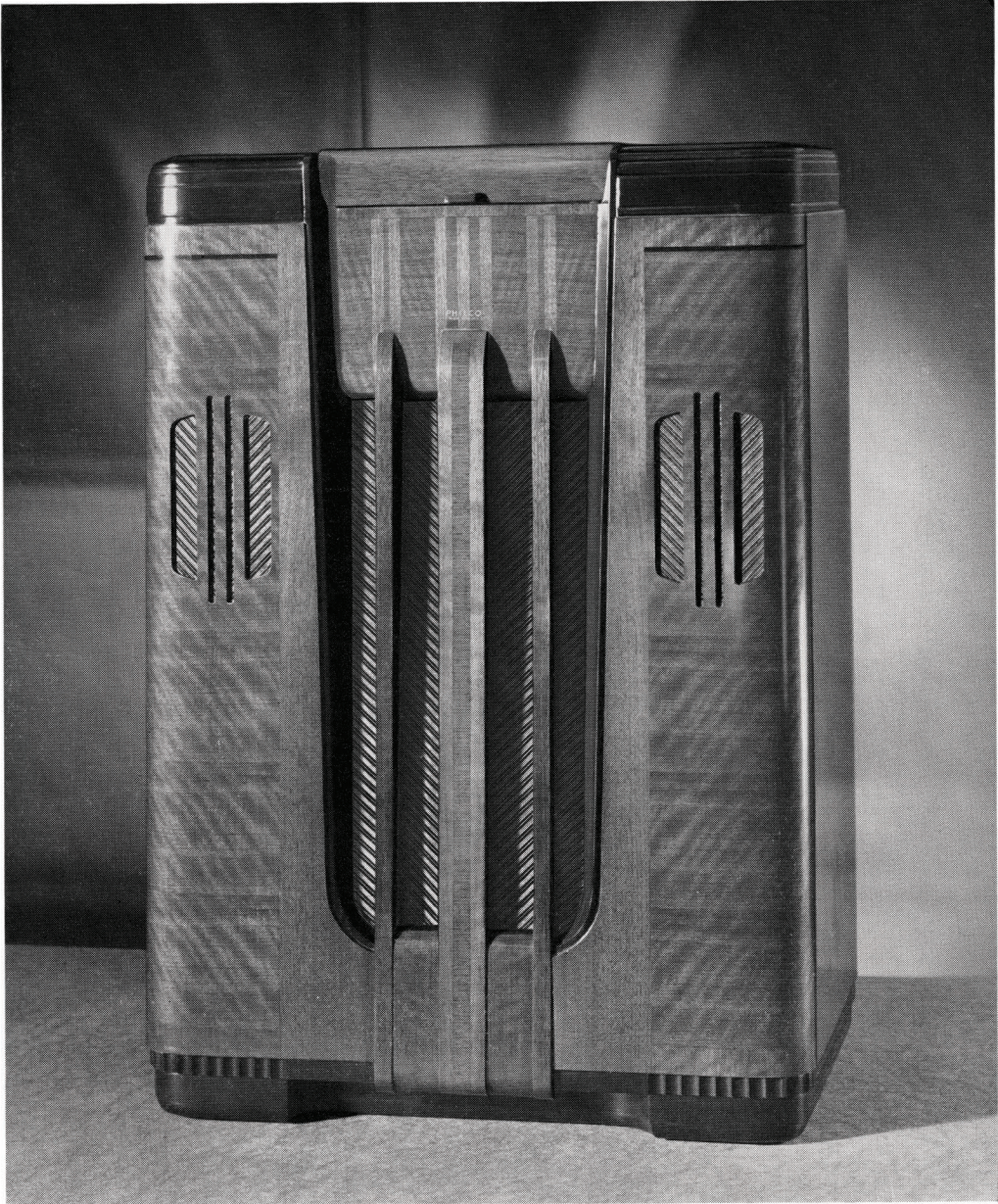

Philco 680X

A Super High-Fidelity Radio deliberately designed to outperform
any radio at any price.

. . . page three

Philco 680X

SUPREME PRODUCT OF THE WORLD'S
GREATEST RADIO LABORATORIES

- In the great Philco experimental and engineering laboratories, a corps of distinguished radio engineers constantly conducts researches into every branch of radio reception . . . striving in every possible way to improve the performance of radios already generally admitted to be entitled to unquestioned leadership.
- Because of this unceasing experimentation, Philco Radios today incorporate every worthwhile advance in radio science and invention. From the smallest Philco to the largest, the regular 1936 models were designed to provide the finest performance and tone quality in their respective price ranges.
- But when all plans had been completed for the regular 1936 line, a direct challenge was issued to the inventive ability and resourcefulness of the greatest radio laboratories in the world:

“Build the finest radio ever designed . . . a radio that will give better performance than any radio at any price . . . the radio you have always dreamed about having for your own home.”

- Philco engineers accepted the challenge . . . figured, planned, experimented, tested and re-tested. After months of concentrated efforts

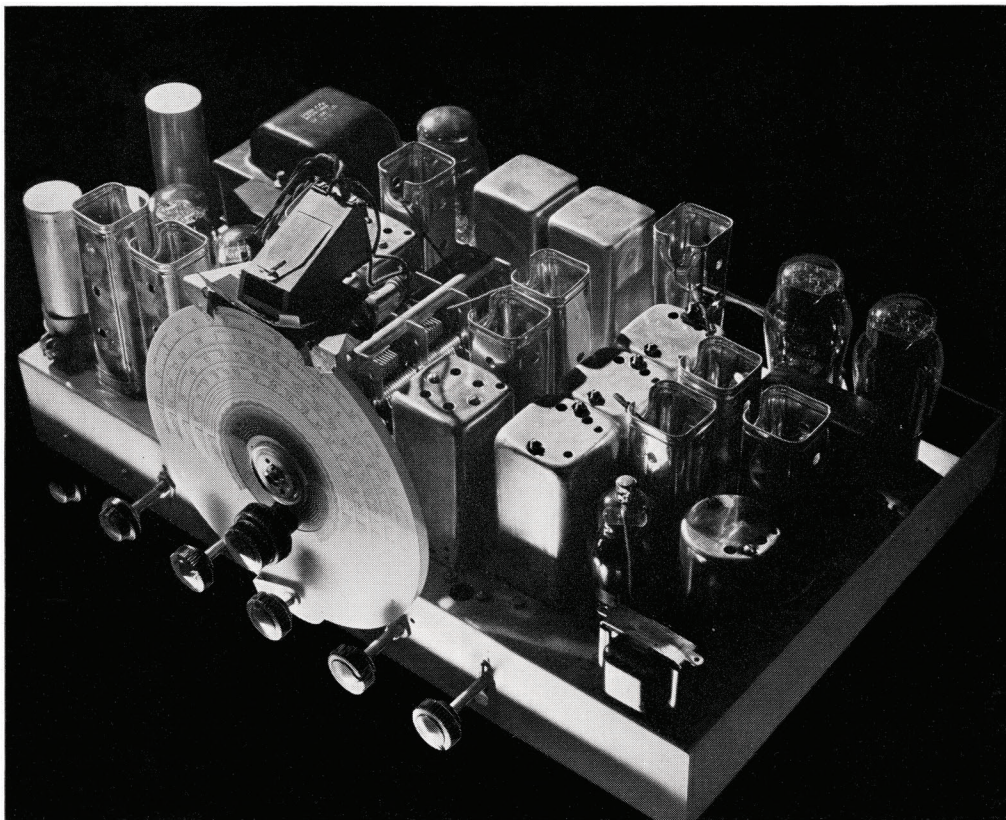

680X chassis, showing massive construction and precision craftsmanship

. . . after experimental models by the score had been subjected to the most searching tests . . . success crowned their efforts . . . success as exemplified by the 680X . . . the Super High-Fidelity Philco!

WHAT IS "SUPER HIGH-FIDELITY"?

- All music is composed of complex notes, which are a combination of a basic tone and higher tones definitely related to the basic tone. These higher tones are the overtones which give timbre and naturalness to vocal and instrumental music and lend individuality to the tone of the many and varied musical instruments.

. . . page five

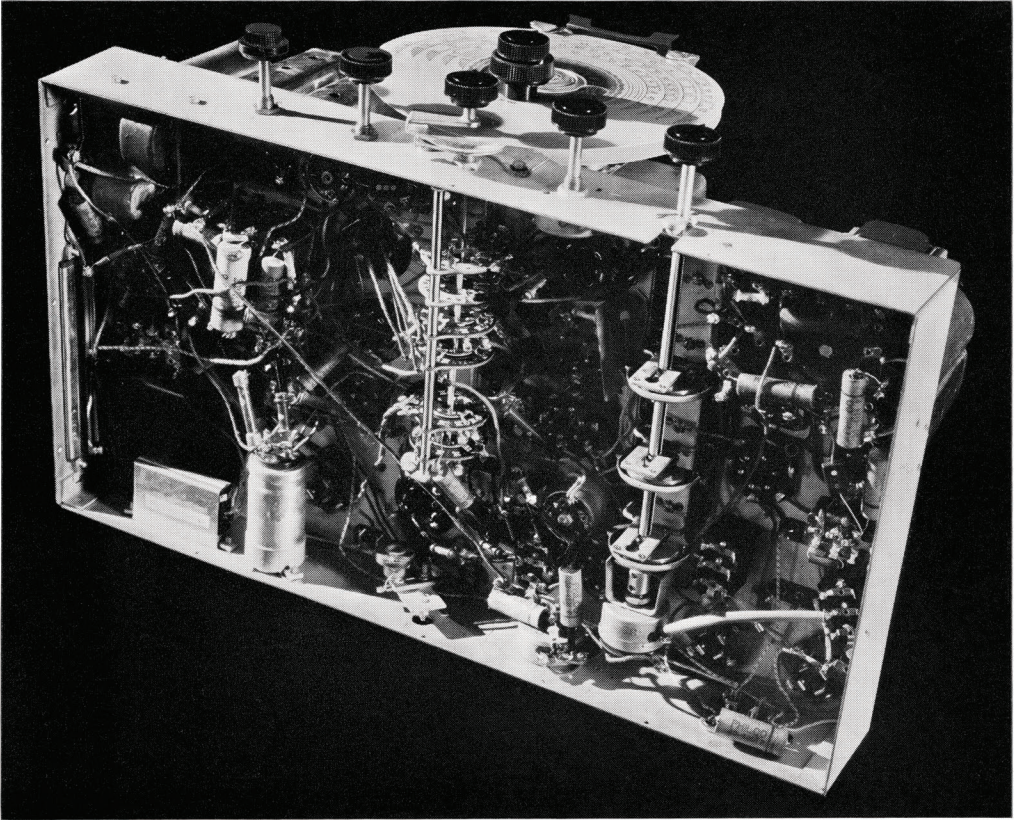

Every part engineered for maximum performance and years of service

- A radio which does not reproduce these overtones sounds unnatural even to the untrained ear. And it sounds woefully deficient in tonal quality to the musically educated.
- Philco pioneered with High-Fidelity Radio. Before the introduction of Philco High-Fidelity, the best radios offered for general sale had a tonal range not exceeding 3000 cycles and could reproduce only a portion of music's important overtones.
- Through Philco research and experimentation a radio was produced in 1934 with a tonal range extending to 7500 cycles. True High-Fi-

delity reception was made practical for public use and enjoyment by several highly important Philco engineering achievements.

- Now in Philco 680X, another noteworthy step forward has been taken. The Super High-Fidelity Audio System of the 680X gives *the widest tonal range, with the most faithful reproduction ever achieved in radio*. All musical instruments, from the deep-toned bass viol to the topmost note of the piccolo, and all voices, are reproduced *with the characteristic overtones* that identify and distinguish them one from another.
- The power output of the 680X assures pure, undistorted tone over the full range of broadcasting, from the faintest whisper in a mystery drama to the thunderous finale of the greatest symphony orchestra.

MUSIC INTERPRETATION CONTROLS

- With Philco 680X, you may interpret any musical selection, played by any orchestra, in the way that expresses your own musical taste. You become the director of the orchestra . . . bend it to your will by adjusting the Treble Fidelity Control to widen the treble range . . . and by using the Bass Fidelity Control to adjust the bass. As you turn these control knobs . . . the orchestra follows your invisible baton. Treble and bass are blended together just as you desire . . . perfectly balanced in accordance with your personal interpretation of the musical selection . . . at any volume . . . on any program.

FOREIGN SHORT-WAVE RECEPTION AT ITS BEST!

- With affairs overseas becoming of greater interest to well-informed Americans each passing day, the ability of any radio to receive Euro-

pean and other foreign short-wave stations with dependable regularity becomes of paramount importance. In this fascinating field, Philco 680X provides performance as outstanding as is its High-Fidelity reception of American broadcasting stations.

- While the news bulletins and expressions of nationalistic opinion probably hold the greatest interest for many short-wave listeners at the present time . . . the musical and dramatic offerings of overseas stations provide many a pleasant hour to the owner of a Philco 680X. So marvelously does this radio perform on distant stations that ordinary barriers of distance vanish . . . and announcers and artists of foreign stations seem actually present in your home.
- With Philco 680X, the great British and Continental short-wave transmitters are received with surprising regularity . . . and unless atmospheric conditions are exceptionally bad, with far greater volume than you will ever require.
- To double the number of foreign stations you can get and enjoy, the 680X is equipped with a built-in Philco All-wave Aerial System. An Aerial Selector which is a component part of the 680X operates in connection with the All-wave Aerial, automatically switching-in the exact electrical values needed to provide maximum power with minimum interference noise on each wave-band. In effect, this provides a separate aerial for each wave-band . . . greatly increasing the clarity and power of both short-wave and standard broadcast reception.



ENGINEERING SPECIFICATIONS

Philco 680X

MAJOR TONE FEATURES

Super High-Fidelity Audio System—15 Watts

The widest tonal range, with the most faithful, life-like reproduction ever achieved in radio! A new audio circuit uses four tubes, two new Philco-engineered type 6A3 High-Fidelity Tubes in the output stage, a type 42 driver tube, and a type 80 tube to supply fixed bias to all audio tubes. Distortion at 15 watts output is negligible—less than one and one-quarter per cent . . . at 30 watts output less than eight per cent. An entirely new system of fixed bias produces amazing fidelity of audio response over the entire fidelity range broadcast by the most modern stations.

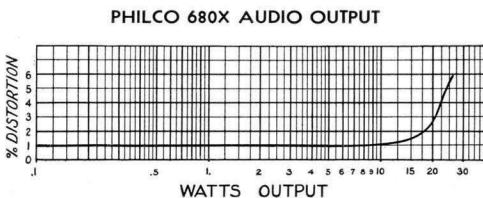

The Philco Super High-Fidelity Audio System has more than 15 watts undistorted output

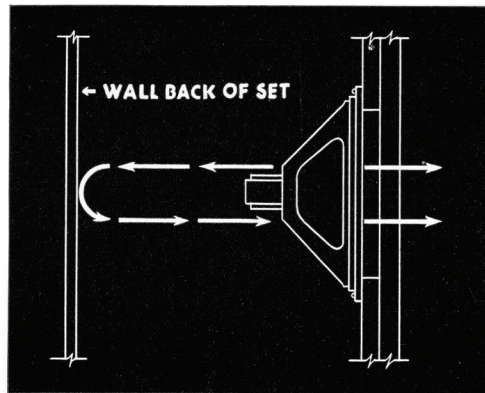

Bass notes rebound from wall and cause distortion in ordinary radios

Acoustic Clarifiers

New and exclusive Philco features which absorb bass notes rebounding from the wall back of the receiver or from the cabinet sides. The clarifiers resemble speaker diaphragms but are connected to resilient material. Interfering echoes which would distort the purity of tone are tuned out and completely absorbed by these Acoustic Clarifiers . . . resulting in clarity and freedom from barrel-like boom beyond all previous radio experience. No

EFFECT OF ACOUSTIC CLARIFIERS IN PHILCO 680-X

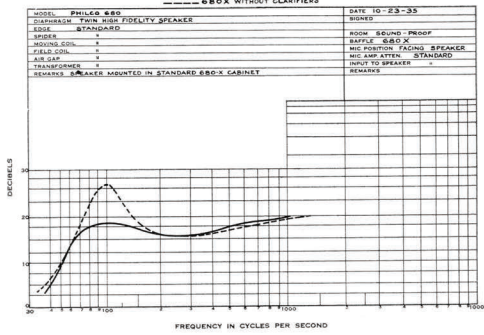

Philco Acoustic Clarifiers prevent cabinet resonance

musically trained ear is needed to detect the relief from “boominess” these Acoustic Clarifiers produce. They effectively absorb the unnatural resonance ordinary radio cabinets inevitably impart . . . and add greatly to your enjoyment of music in which deep, rich tones predominate.

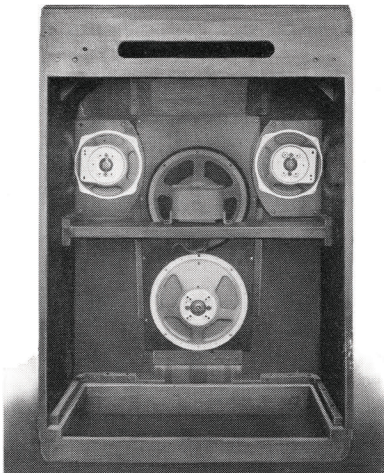

Philco Acoustic Clarifiers are accurately tuned for the 680X cabinet

New High-Fidelity Tubes— Exclusive with Philco

The new Philco-designed type 6A3 High-Fidelity audio tubes overcome the disadvantages of ordinary output tubes. The new low-impedance characteristics lend themselves admirably to the reproduction of both high and

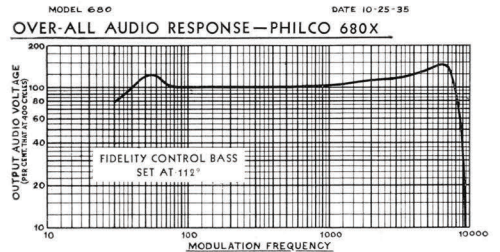

The 680X reproduces low and high notes in correct proportion

low notes. These inherent characteristics are in no small way responsible for the excellence of performance attained in the Super High-Fidelity System of the 680X. The knowledge and experience gained in the production of over six million receivers are combined in

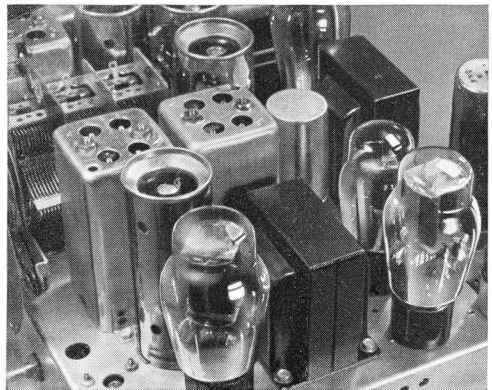

Philco Super High-Fidelity Audio System

the design and manufacture of these new type tubes — pioneered by Philco.

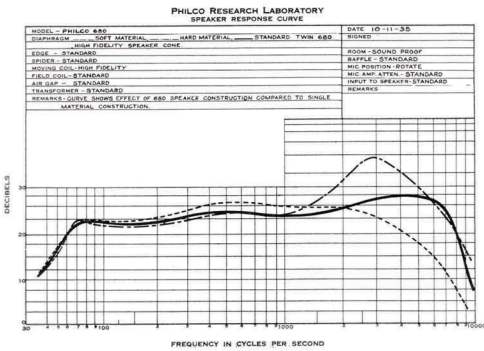

- Curve showing speaker response with hard cone material.
- Curve showing speaker response with soft cone material.
- Curve showing how 680 Twin High-Fidelity Speaker reproduces low and high notes uniformly.

Two-in-One High-Fidelity Speaker

Philco engineers perfected this twin High-Fidelity Speaker to reproduce all the frequency range produced by the Philco High-Fidelity Audio System. The dual cone has a stiff center especially adapted for the reproduc-

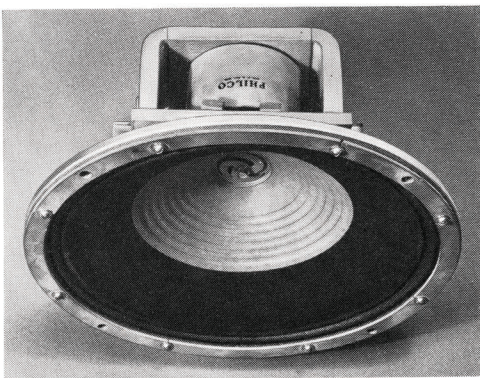

Two-in-one High-Fidelity Speaker. Auditorium volume without distortion

tion of high notes, and a flexible outer cone for the reproduction of the low notes. The combination of these two cones results in a speaker capable of full auditorium volume and complete frequency response without distortion.

Music Interpretation Controls

Two controls on the 680X instrument panel enable the discriminating listener to interpret any selection to suit his own individual taste . . . in other words, to become his own orchestra conductor!

1. FIDELITY CONTROL—TREBLE

This control varies the coupling of six of the seven intermediate fre-

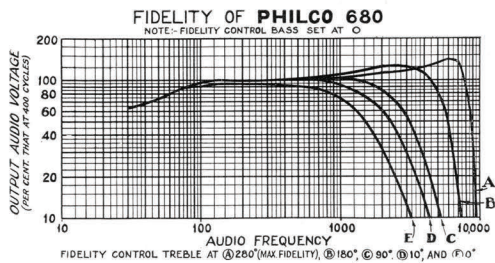

The Fidelity Control Treble permits maximum high note response for any broadcasting condition

quency amplifier circuits. As this control changes the coupling of the tuned I. F. circuits, the overall bandwidth is extended to fit any given broadcast condition. The R. F., detector, and oscillator produce a High-Fidelity signal which is regulated by the Fidelity Control Treble to produce either wide-range, Super High-Fidelity or a narrow-band, highly-selective signal for use in crowded

portions of the standard or short-wave bands. Through this control you can get all the treble possible . . . hear all the high notes broadcast . . . widen the frequency response to the maximum usable under any given broadcast condition.

2. FIDELITY CONTROL — BASS

This control regulates a new type bass note amplifier stage which permits perfect adjustment of the low-

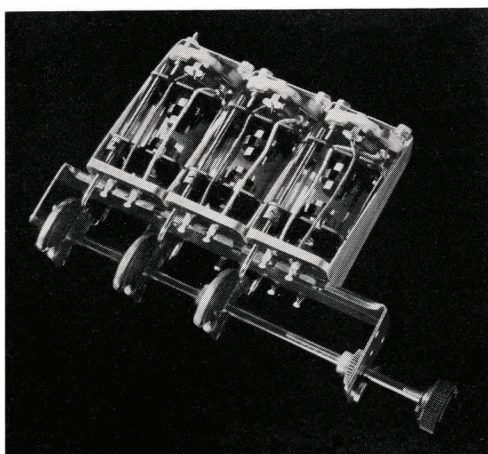

Philco Fidelity Control Treble

note volume to the sound level of the selection being played. At ordinary room volume a certain amount of bass amplification adds greatly to the reality of the reproduced selection. At high volume this compensation is unnecessary since then the ear hears the bass notes in their proper proportion. At low volume, accurate reproduction demands the full range of compensation provided in 680X. Through proper use of this control, the audio

bass response of the 680X is uniform regardless of volume level. When desired . . . especially in the case of speech . . . bass may be reduced to the point at which the greatest clarity is attained.

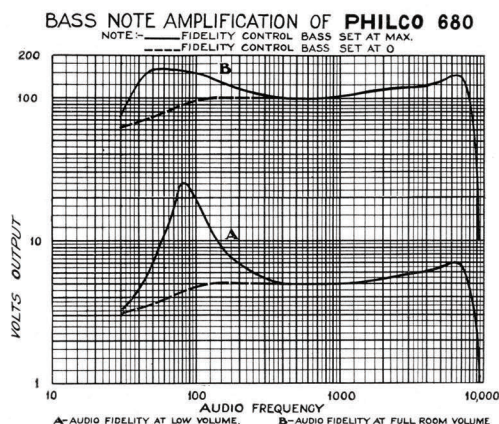

Amplified Bass Compensation provides bass emphasis at low volume. Automatic Resonance Governor prevents overloading during loud passages

Automatic Resonance Governor

A special circuit regulates the bass amplifiers and automatically limits distortion which would otherwise occur during loud passages.

BUILT-IN SOUND DIFFUSERS

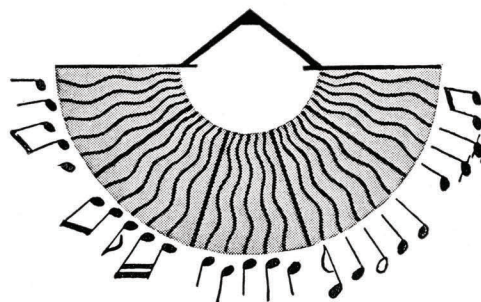
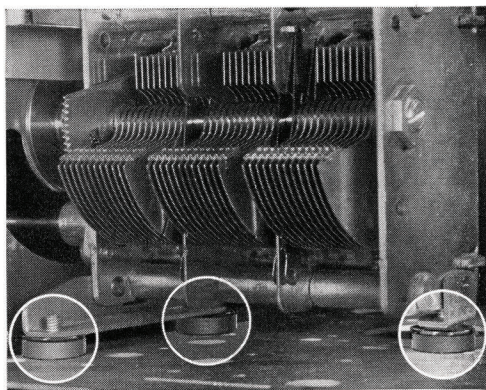

Diagram shows how Philco Sound Diffusers spread high notes

Wide Angle Sound Diffusion

The 680X is housed in a special sound-diffusing cabinet which spreads all sound evenly throughout the room. High notes in particular tend to concentrate in a beam in front of the speaker, but through Philco Wide Angle Sound Diffusion they are so deflected that the correct proportions of all frequencies are heard in all parts of the room.



Master Tuning Condenser mounted on live rubber

Live Rubber Condenser Mounting

A patented Philco feature, the mounting of the tuning circuit on live gum rubber, prevents the transmission of speaker vibration to the delicate tuning circuit, thus eliminating microphonic noise. In ordinary radios, microphonic trouble is avoided by omitting important audio frequencies, leaving gaps in the musical scale readily detected by the musical ear. In Philco receivers the use of live gum

rubber mounting makes it possible to reproduce all audio frequencies over the entire range of the instrument. This is especially important in a radio with the wide musical range of the 680X.

Amplified Shadow Tuning

For perfect tone you must have perfect tuning. So Philco provides in the 680X a separate tube amplifier operating a visual "Shadow Tuning" meter. Quickly, accurately, visually — as you turn from station to station — the shadow on the Philco dial automatically narrows to a minimum width for each station and at that point the set is tuned so perfectly that not a single overtone is lost.



Philco Shadow Tuning proved by years of use in millions of Philcos

PHILCO INCLINED SOUNDING BOARD

All of the features previously described, important as they are, would fall short of delivering to your ear perfect, well-rounded, High-Fidelity tone without the Inclined Sounding Board . . . one of the most famous and most vital of exclusive Philco developments.

All the purity of tone produced by the carefully engineered circuits of the 680X, all the full range of frequencies reproduced by the speaker,

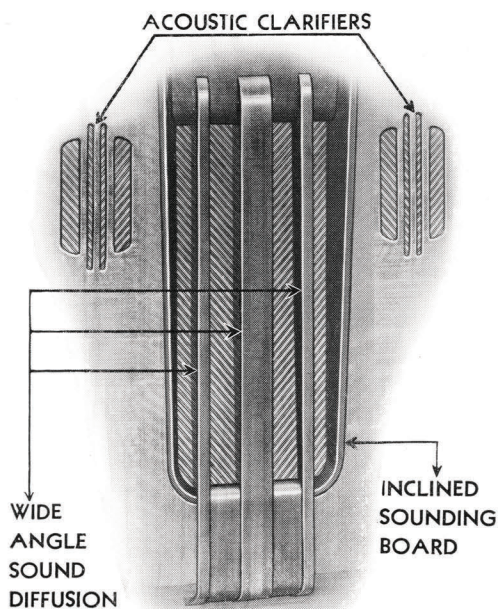

Built-in Sound Diffusers spread high notes throughout the room

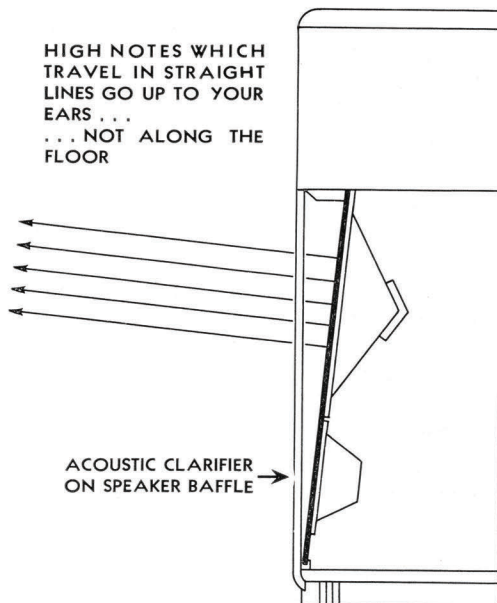

would be sacrificed to a considerable extent if not directed up to ear-level by the famous Philco Inclined Sounding Board.

The high notes which tend to travel in a straight line are projected along the floor from an ordinary type cabinet. The Philco Inclined Sounding Board directs them up to the ear-level of a seated listener—thus preserving all the extended musical range and clarity of tone created by the Philco Super High-Fidelity Audio System and Philco Acoustic Clarifiers.

Philco 680X

MAJOR ELECTRICAL FEATURES

Philco Balanced Superheterodyne Circuit

The Philco 680X is in every sense a custom-built radio. Its design is so advanced . . . the standards of workmanship set by the engineers are so high—that only the most skilled radio craftsmen in Philco's employ are entrusted with the construction. These highly skilled technicians achieve an exact matching of component parts through exhaustive selection. Precision matching, followed by the progressive alignment of succeeding stages in the custom adjusting of the superheterodyne circuit, result in new high standards of overall performance.

a. OVERALL SENSITIVITY

Comparative sensitivity measurements alone do not express the real performance ability of a radio, as beyond a certain point sensitivity tends to become unmanageable and worse than useless. Unless properly harnessed and controlled, extreme sensitivity makes a set noisy and regenerative.

In the 680X great sensitivity is provided, but every precaution has been taken in design and construction to keep this sensitivity under control at all times. The graph reproduced below shows the available sensitivity on all wave bands of the 680X . . . sensitivity fully controlled and extremely useful. The technically minded can readily understand from this graph the tremendous power available in the 680X. And it should be borne in mind that this power is properly harnessed, controlled and directed so that this extremely powerful radio is extremely quiet while being tuned.

The 680X attains maximum sensitivity on the important 6 megacycle (49 meter) night-time, Foreign and American band.

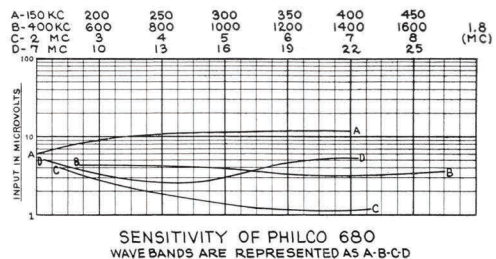

b. HIGH-FIDELITY OSCILLATOR

The new High-Fidelity Oscillator stage is designed to give absolute stability, freedom from drift, constant signal output and exact permanent alignment with the R. F. signal over the entire range from 145 K.C. to 22.5 megacycles. The exclusive new 680X precision oscillator, designed by Philco engineers, overcomes the limitations which an ordinary oscillator stage imposes on reception of the highest quality. Super High-Fidelity is achieved on *every* channel of the *broad-cast band*. Tracking of every band is assured through custom adjustment of padding condensers which independently compensate the tuning of each wave-band. Heat and moisture-proof materials are used in all aligning condensers to resist temperature and humidity.

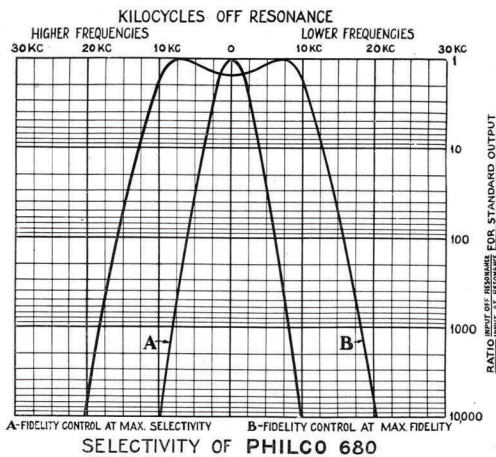

Points 10 KC, 20KC and 30 KC are stations on adjacent broadcast channels. When these stations are weak, position "B" of the Fidelity Control Treble is desirable. When strong, position "A" may be used.

c. HIGH-FIDELITY DETECTOR CIRCUIT

An individual detector circuit makes possible freedom from drift, the complete mixing of R. F. and oscillator signals, and assures more effective automatic volume control, constant full-range sensitivity and increased amplification in the detector circuit.

d. HIGH GAIN RADIO FREQUENCY CIRCUIT

The custom-built 680X Radio Frequency circuit amplifies station signals more than twice as much as the R. F. amplifier in the ordinary set. This extra amplification eliminates background noise in the 680X.

Non-Radiating

The complete shielding of circuits and tubes prevents any radiation from the 680X chassis, protecting other sets in the vicinity from any interference from the powerful oscillator in this Philco.

Power Line Noise Rejectors

A built-in filter prevents interference noises from entering the chassis through the A.C. cord. Double protection against interference noise is afforded by the Built-in All-wave Aerial System which completely shields the incoming radio program — from the aerial to the terminals of the antenna coils.

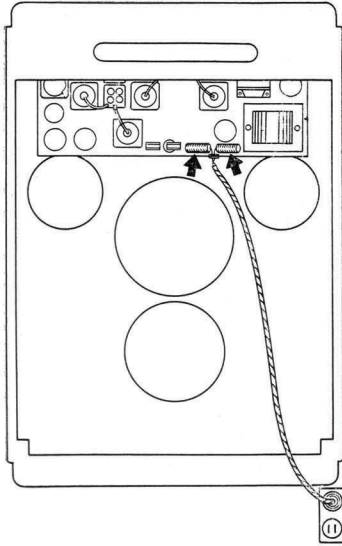

Power Line Noise Rejectors

Fifteen Philco High-Efficiency Tubes

This mighty combination of powerful tubes, matched and balanced each with the other, actually gives the power and selectivity of twenty or more less-efficient tubes. The choice of the types used was dictated by experience and was not limited by cost. The ideal tube for each function of the chassis has been selected. The use of Philco High-Efficiency Tubes permits extremely short leads in R. F.

and I. F. amplifier circuits resulting in low loss and higher amplification. The world's most efficient I. F. amplifiers are used, the world's most stable oscillator tube is utilized, and the most rugged rectifier tube supplies the current. Wherever possible multiple-function tubes are used and the new high-fidelity 6A3 audio tubes produce more than twice the undistorted output of ordinary audio tubes.

Rigid Chassis Base

Permanent alignment of every custom-adjusted stage in the chassis is guaranteed by the assembly of the completed 680X on rigid rust-proofed steel.

Completely Shielded

Radio circuits and tubes are metal shielded throughout to attain maximum amplification and additional protection from radio interference.

Safe from Fire and Shock

Philco 680X is built to conform in every respect to the Underwriters' Safety Standards.



Philco 680X

MAJOR ALL-WAVE FEATURES

Broadcast Band Coverage

The tuning range of the 680X is widely spaced over four wave bands to attain maximum performance on each broadcast service. The band coverages are:

- (A) United States Government Weather Reports—148-406 K.C.
- (B) Standard American and Police Call Band—525-1750 K.C.
- (C) Police Call, Aircraft, Ship, Amateur, and Night-time Foreign and American Short-Wave Broadcast Band—2.27-7.3 Meg.
- (D) Daylight and Night-time Foreign and American Short-Wave Band—7.17-22.2 Meg.

An important feature of the band coverage is the wide spreading of stations in the crowded short-wave bands. The tuning circuit is amazingly sen-

sitive on the important 6-megacycle band, thus achieving finer performance than previously possible on this popular night-time short-wave band.

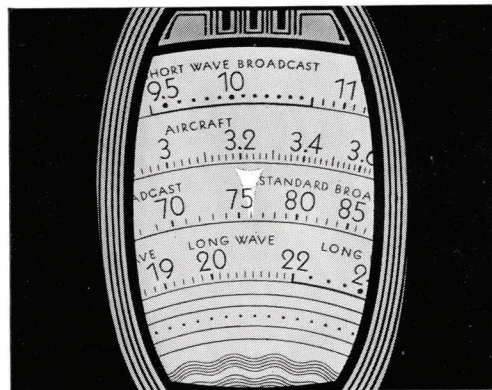

Glowing Arrow Wave-Band Indicator shows wave band in use

Glowing Arrow Wave-Band Indicator

A special shifting mechanism directly coupled to the wave-band switch shifts a glowing arrow to the band selected. This glowing arrow not only indicates the wave-band in use, but acts as a station finder of great accuracy.

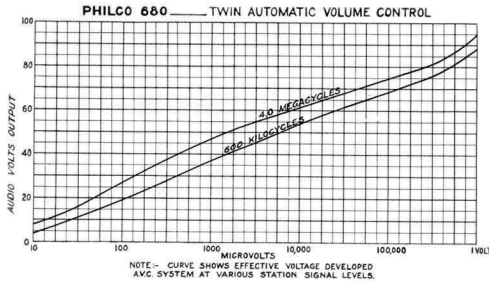

Radio Frequency and Diode Automatic Volume Control Circuits prevent fading or blasting of stations

Twin Automatic Volume Control

Fading of distant stations and blasting of powerful nearby local broadcasters is doubly counteracted in the Philco 680X. The first automatic volume control circuit is applied to the “noise excluding signal amplifier” and is used to overcome interference from powerful local stations. The second automatic volume control circuit is incorporated in the second detector stage and controls the fading of distant stations. The overall automatic volume control thus obtained results in better regulation of fading stations plus the elimination of powerful local station interference, greater stability and better performance on all wave bands.



- SHADOW TUNING
- D. FOREIGN BROADCAST
- C. POLICE, AIRCRAFT, AMATEUR, FOREIGN
- B. STANDARD AMERICAN
- A. U. S. GOVERNMENT WEATHER REPORTS

Precision Radio Dial

The widely spread station settings make this the easiest radio dial to use whether tuning distant or nearby stations. The extreme clarity of the numbers, the marking of the various broadcast services at the proper points and center-line tuning result in the easiest, most precise, tuning in all radio.

Even the more crowded short-wave bands are so arranged as to simplify greatly the accurate tuning of foreign stations.

Two-Speed Planetary Drive Station Selector

A newly designed two-speed control provides a fast speed for swift turning to the portion of the scale desired and a slow speed for precision tuning of short-wave stations. This easily oper-

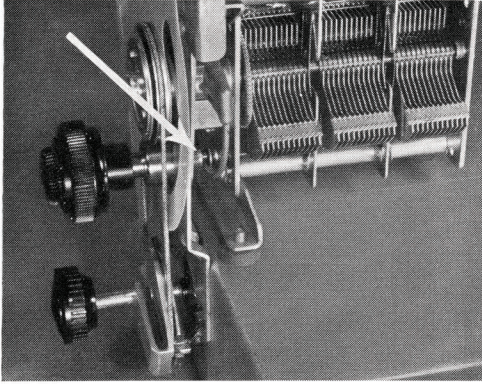

Two-speed Planetary Drive Station Selector

ated slow speed is available at all times without shifting of levers or resetting of control knobs. By simply changing from the large knob to the smaller one, the precision tuning required for High-Fidelity reception as well as for short-wave stations is instantly available.

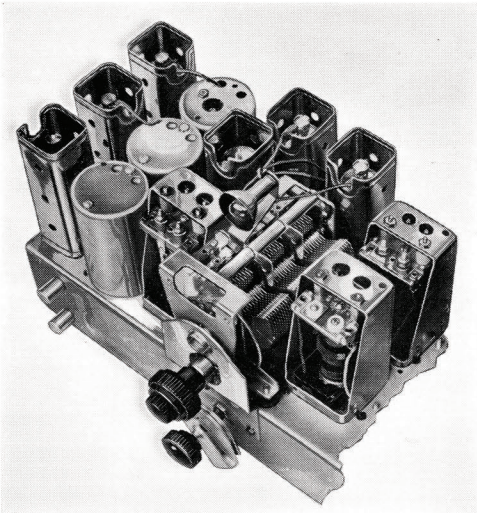

Quiet Signal Amplifier

Quiet Signal Amplifier

An automatic pre-selector R. F. amplifier stage tunes and amplifies broadcast band and short-wave stations. This also increases sensitivity and reduces background noise and interference from other broadcast signals. The Quiet Signal Amplifier operates mechanically and automatically as the tuning knob is turned.

Triple Selector System

(a) WIDE RESPONSE R. F. AMPLIFIER STAGE:

A newly perfected wide response R. F. amplifier stage extends beyond single channel width and amplifies a band equal to 13,000 cycles on both sides of the station carrier. This new high-fidelity R. F. circuit produces an amazing degree of signal amplification and at the same time rejects interference from other broadcast signals.

(b) QUIET SIGNAL AMPLIFIER:

In addition to its function of amplifying station signal strength, this amplifier adds tuned R. F. circuits in advance of the first detector tube, contributing in a marked degree to the over-all performance of the receiver.

(c) SEVEN TUNED I. F. CIRCUITS:

Variable coupling of the I. F. amplifiers gives a range of selectivity never before available in a radio set. With control in the maximum selectivity position an adjacent channel rejection of 1800 to 1 is attained as

The Acoustic Chart portion of the diagram below, which shows the fundamental frequencies and overtones of most musical instruments and voices, was compiled by and is used through the courtesy of The Franklin Institute, Philadelphia, Pa.

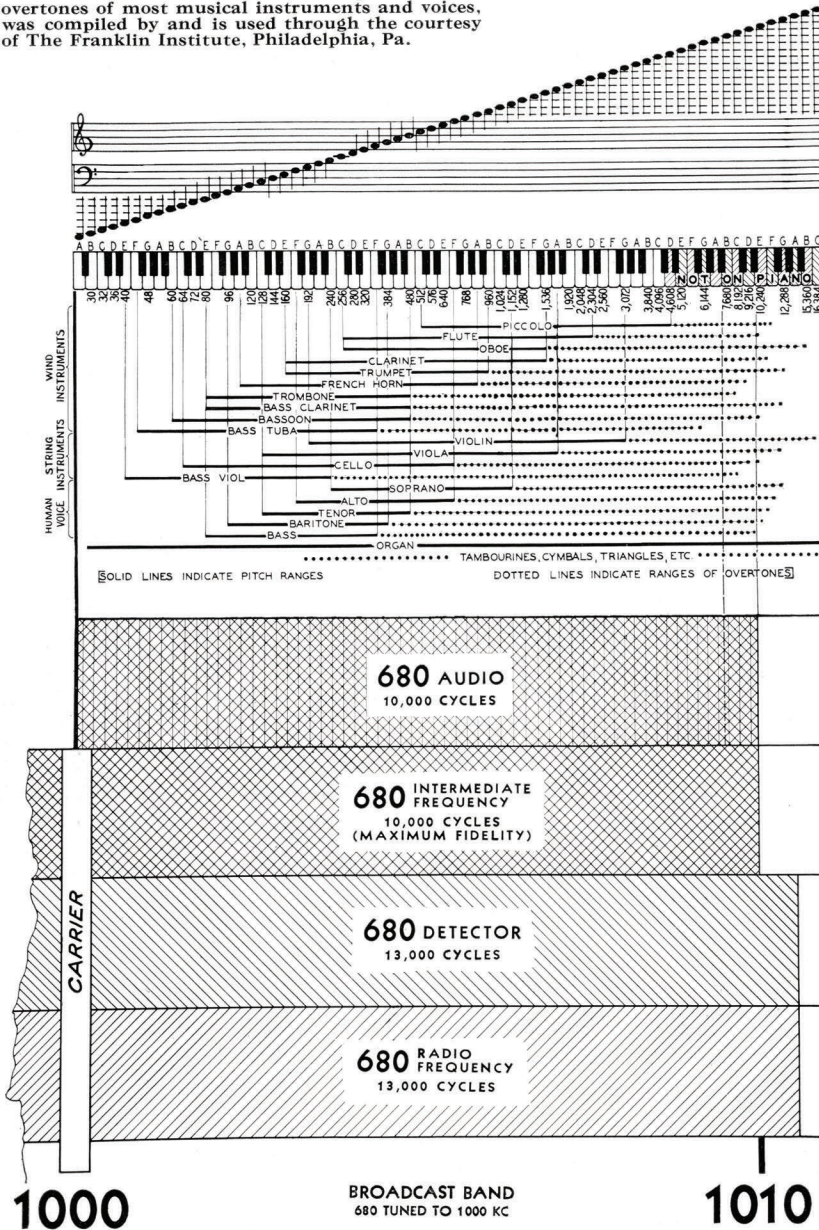

This chart shows that the Philco 680X reproduces all musical instruments and all voices with the overtones which identify and distinguish them one from another. Overall response of Philco 680X is as shown. A filter in the Audio System prevents interference from adjacent channels. This 10,000-cycle filter decreases response above 7500 cycles, the point indicated by vertical dotted line in the diagram.

compared to rejections of 100 or 150 to 1 in ordinary first quality receivers. This selectivity is especially valuable when tuning distant stations while powerful close-by American transmitters are on the air.

Cabinetry

In the 680X the same care has been given to appearance as to perform-

ance. The masterfully engineered chassis is housed in a cabinet that is a triumph of the furniture designer's art. The finest of cross-fire striped walnut, in matched panels with marquetry and gracefully curved pilasters, is used in a cabinet of such distinction that it will enhance the appearance of the most beautifully furnished room.

EXCLUSIVE PHILCO BUILT-IN ALL-WAVE AERIAL SYSTEM

To span oceans and pick up short-wave broadcasts from thousands of miles away, a scientifically designed aerial system is absolutely essential.

Noise from man-made static and local electrical interference, which is annoying enough on standard American broadcasts, may make overseas short-wave reception impossible unless proper scientific steps are taken to overcome these disturbances.

To assure the finest reception and complete utilization of the full powers of the 680X, a built-in All-wave Aerial System is made an integral part of the set.

The Aerial Selector automatically balances the built-in transformers of the All-wave Aerial System to maintain maximum sensitivity on each wave-band. These special matching transformers eliminate interference . . . give higher efficiency . . . and overcome losses which would other-

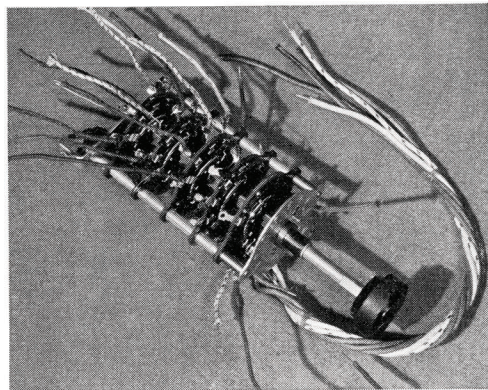

Built-in Automatic Aerial Selector matches radio frequency circuits to Philco All-wave Aerial System

wise occur in the wide range of frequencies covered by the 680X.

The Philco All-wave Aerial System is completely automatic in its action. Turning one knob not only shifts the wave bands but also selects and connects the proper aerial for that band.

Through this exclusive Philco built-in All-wave Aerial System you actually get and enjoy more than double the number of foreign stations!

HEAR THE WORLD'S FINEST RADIO
WHERE YOU CAN JUDGE IT BEST
. . . IN YOUR OWN HOME!

*W*ithout charge or obligation the Philco dealer in your community will install a 680X for a suitable demonstration period right in your own home. There, in the comfort of your living room, put this finest of radios to any test your imagination may suggest!

- Thrill to programs from London . . . Berlin . . . Paris . . . and other foreign cities. Keep in touch with the onward sweep of world events through the news bulletins . . . broadcast in English . . . from European capitals. Such clarity . . . such volume . . . such surprising regularity of reception from overseas is possible only with a Philco 680X with its Built-in All-wave Aerial System.
- When you listen to a favorite American program, the 680X quickly reveals the meaning of Super High-Fidelity reception. You hear the overtones which give natural, lifelike quality to the human voice. Each instrument in an orchestra is readily identifiable . . . as clearly distinguishable from all other instruments as if you were right in the concert hall!
- Your Philco dealer will gladly arrange a home demonstration of the 680X . . . and if you so desire, will arrange for its purchase on the Philco Commercial Credit Time Payment Plan.

PHILCO RADIO & TELEVISION CORPORATION
PHILADELPHIA, PA.

