

PHILCO TRANSITONE SERVICE BROADCAST

APRIL, 1934

MODEL 11 RECEIVER

THE PHILCO auto radio Model 11 is a new Philco development in single-unit automobile radio. It is compact, easy to install and will give exceptional performance.

A superheterodyne, using six of the latest tubes designed for automobile radio, it has a genuine Philco electro-dynamic speaker, the same type that is used in many of the larger home radio Receivers. A three-section tuning condenser giving improved selectivity, remarkable sensitivity and tone, inherently quiet circuits and other improvements make this model one of the outstanding and most popular automobile radios.

Added to this, the ease of installation characteristic of this model (only one unit to install, one lead to the antenna and one lead to the ammeter) and the handy, attractive steering-column control which makes this model universal in its use are additional features which make the Model 11 a very desirable one for the dealer and for the owner.

I. F. TRANSFORMER AND PADDERS

The new style I. F. transformer complete with padders is used in the Model 11.

The padders are placed in the top of the shield can one above the other.

The primary padder is adjusted by means of the screw slot, accessible through the hole in the top of the shield can. The secondary padder is adjusted by means of the small hex nut, also accessible through the hole in the top of the shield. (See Figs. 1 and 2.)

The coil windings terminate in leads instead of terminals or lugs. The color scheme of the leads is given in Fig. 1.

If replacements are ever necessary, replace the entire coil assembly 32-1329 for the first I. F. stage and 32-1237 for the second I. F. stage. Neither the coil nor the padders will be furnished separately. Order only by the above numbers.

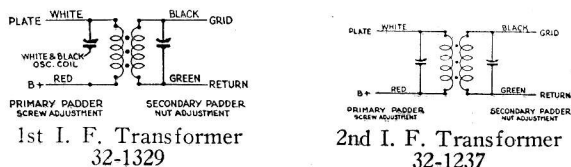

FIG. 1

MODEL 11 ADJUSTMENTS

All adjustments have been carefully checked at the factory. If, however, it is found necessary to readjust the padding condensers, this procedure must be followed carefully. Do not attempt to make any adjustments until the procedure is clearly understood or without the use of a good oscillator or signal generator and output meter. The Philco Set Tester 048 is highly recommended for this procedure and for all service work.

The Receiver must be connected to a six-volt storage battery and turned on for operation. It is assumed that tubes have been checked and that the Receiver is in good condition except for the padding adjustments.

Remove the speaker lid from the Receiver. Remove the grid cap terminal from the 77 tube (for location see Fig. 2).

Set up the signal generator and adjust it to exactly 260 K. C. Connect the generator lead to the grid cap of

the 77 tube. (See Fig. 2.) The output meter must be connected.

The Receiver volume control must be turned on to approximately full volume and the attenuator in the generator set for a half-scale reading of the output meter.

The padders ② and ④ are adjusted first (Figs. 2 and 3). Turn the adjusting screw ② all the way in. A metal screwdriver can be used for this. Then, with generator attenuator set so there is approximately half-scale reading, adjust the nut ④ with a fibre wrench for the maximum reading on the output meter.

Then adjust the screw ② for maximum reading on the meter. This adjustment is critical. Note the maximum reading obtainable and then turn the screw in again and readjust, just bringing the adjustment up to the maximum reading. Do not pass it and then back off.

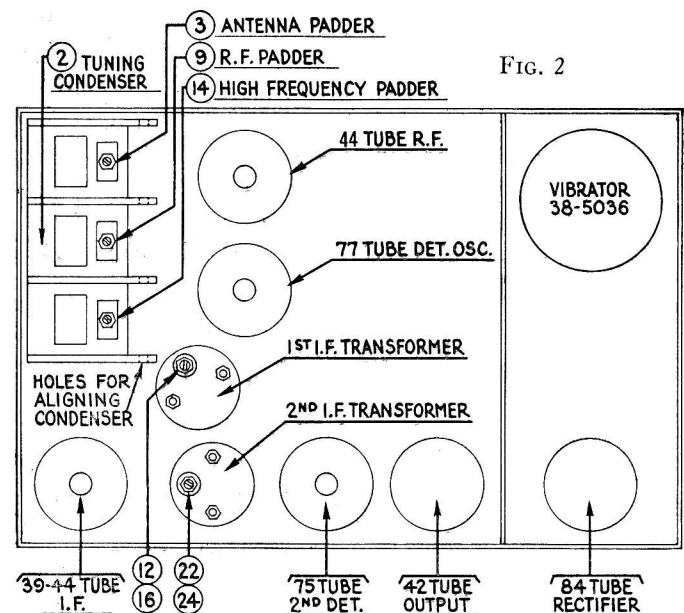

FIG. 2

Repeat the above procedure with the condensers ⑫ and ⑩.

After padding the first I. F. stage, remove the generator lead from the 77 tube and reconnect the grid lead to the 77 tube. Set the generator to 1500 K. C. and then connect the generator lead to the antenna lead.

There are four holes in line, one in each of the sections

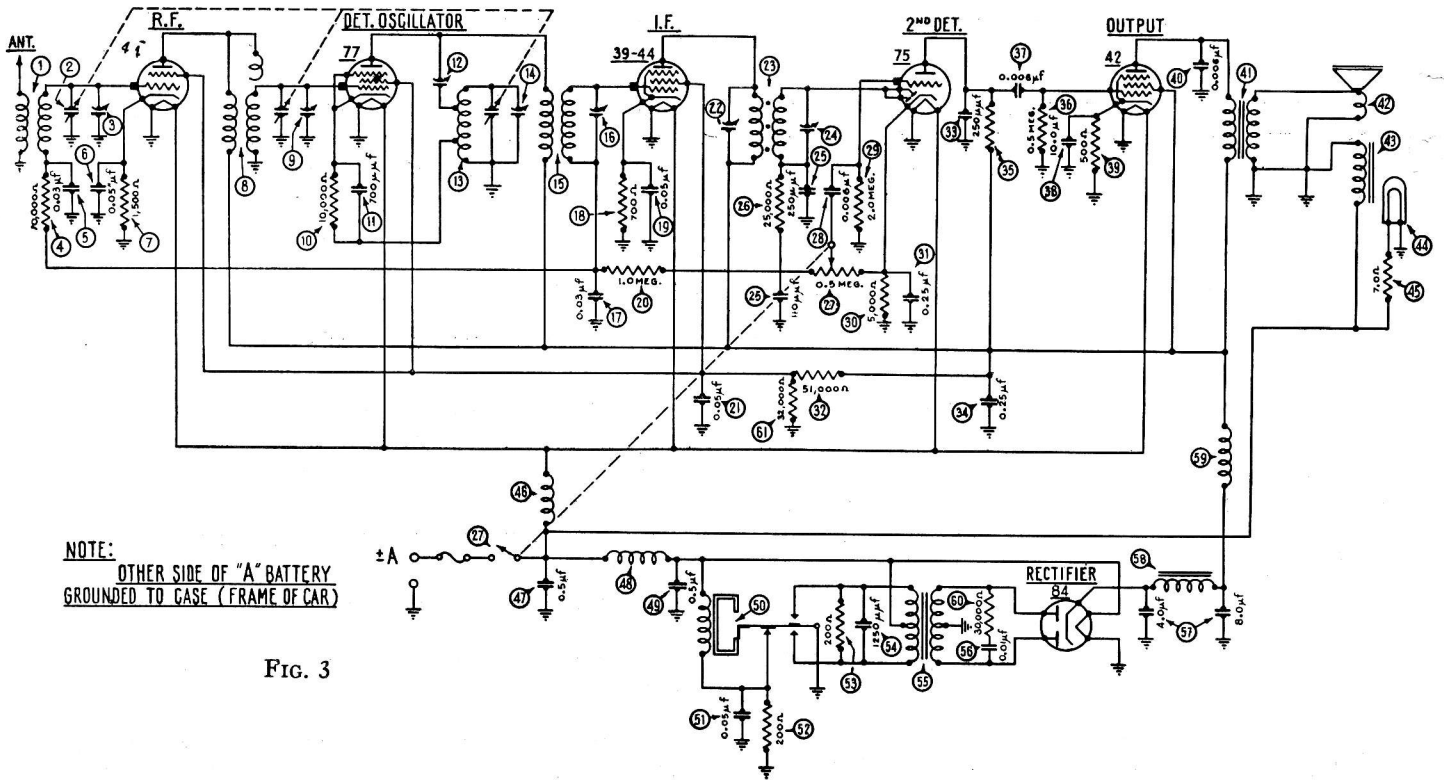

FIG. 3

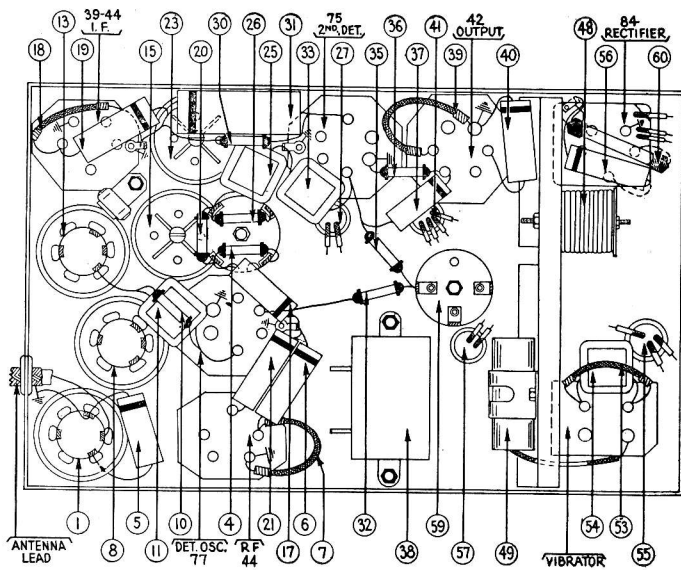

FIG. 4

of the tuning condenser housing. (See Fig. 2.) Place a nail of the size that fits snugly through the holes and then turn the condenser plates out of mesh until they strike against the nail.

With the tuning condenser in this position adjust the high-frequency padder (14) until the maximum reading is obtained in the output meter. This is the true setting for 1500 K. C., 150 on the dial scale.

Next turn the condenser plates in mesh to 140 on the scale, 1400 K. C., and set the signal generator for 1400 K. C. The R. F. padder (9) and the antenna padder (3) are next adjusted for the maximum reading on the output meter.

Recheck the adjustments and then remove all test leads. If this procedure has been carefully followed and an accurately calibrated oscillator or signal generator used, the Receiver is adjusted properly.

MODEL 11 PARTS LIST

① Antenna Transformer.....	32-1331	④⑨ Field Coil Assembly.....	36-3097
② Tuning Condenser.....	31-1149	④④ Pilot Light.....	6608
③ 1st Padder (on tun. cond.).....		④⑤ Resistor (7 ohms).....	33-3035
④ Resistor (70,000 ohms).....	33-1115	④⑥ "A" Choke.....	32-1268
⑤ Condenser (.03 mfd.).....	30-4025	④⑦ Condenser (.5 mfd.).....	30-4047
⑥ Condenser (.05 mfd.).....	30-4020	④⑧ Vibrator Choke.....	32-1235
⑦ Resistor (1500 ohms).....	33-3047	④⑨ Condenser (.5 mfd.).....	30-4147
⑧ R. F. Transformer.....	32-1332	⑤⑩ Vibrator Unit.....	38-5036
⑨ 2nd Padder (on tun. cond.).....		⑤① Condenser (.05 mfd.).....	30-4039
⑩ Resistor (10,000 ohms).....	33-1000	⑤② Resistor (200 ohms).....	7217
⑪ Condenser (.0007 mfd.).....	5863	⑤③ Resistor (200 ohms).....	7217
⑫ Padder (Prim. 1st I. F. Tran.).....		⑤④ Condenser (.00125 mfd.).....	5886
⑬ Oscillator Transformer.....	32-1333	⑤⑤ Power Transformer.....	32-7216
⑭ 3rd Padder (on tun. cond.).....		⑤⑥ Condenser (.01 mfd.).....	30-4051
⑮ 1st I. F. Transformer.....	32-1329	⑤⑦ Condenser (4-.8. mfd.).....	30-2072
⑯ Padder (Sec. 1st I. F. Tran.).....		⑤⑧ "B" Choke.....	32-7215
⑰ Condenser (.03 mfd.).....	30-4025	⑤⑨ R. F. Choke.....	32-1281
⑱ Resistor (700 ohms).....	6443	⑤⑩ Resistor (30,000 ohms).....	7836
⑲ Condenser (.05 mfd.).....	30-4020	⑤⑪ Resistor (32,000 ohms).....	3525
⑳ Resistor (1,000,000 ohms).....	33-1096	Spark Plug Resistor.....	33-1015
㉑ Condenser (.05 mfd.).....	30-4020	Distributor Resistor.....	4546
㉒ Padders (Prim. 2nd I. F.).....		Screw Type Resistor.....	4851
㉓ 2nd I. F. Transformer.....	32-1237	Interference Condenser.....	30-4007
㉔ Padder (Sec. 2nd I. F. Tran.).....		Dial.....	27-5038
㉕ Cond. (.00011-.00025 mfd.).....	30-1020	Studs.....	28-6036
㉖ Resistor (25,000 ohms).....	33-1013	Nuts (mounting).....	W55A
㉗ Vol. Con. and Switch Assm.....	33-5058	Knobs (tuning).....	03334
㉘ Condenser (.006 mfd.).....	30-4125	Knobs (volume).....	06886
㉙ Resistor (2,000,000 ohms).....	33-1025	Battery Cable.....	38-5296
㉚ Resistor (5000 ohms).....	33-1001	Acorn Nut.....	W821
㉛ Condenser (.25 mfd.).....	30-4146	Key.....	6091
㉜ Resistor (51,000 ohms).....	5868	Fuse.....	7227
㉝ Condenser (.00025 mfd.).....	3082	Fuse Insulator.....	27-7131
㉞ Condenser (.25 mfd.).....	04360	4-Prong Socket.....	27-6006
㉟ Resistor (100,000 ohms).....	6099	5-Prong Socket.....	27-6014
㊱ Resistor (500,000 ohms).....	6097	6-Prong Socket.....	6417
㊲ Condenser (.006 mfd.).....	30-4125	Cont. Unit Assm. (Dir. Dr.).....	42-5150
㊳ Condenser (10 mfd.).....	7440	Shafts—Tuning.....	28-8139
㊴ Resistor (500 ohms).....	33-3031	Volume.....	28-8141
㊵ Condenser (.006 mfd.).....	30-4024	Cont. Unit Assm. (Gr. Dr.).....	42-5157
㊶ Output Transformer.....	32-7214	Shafts—Tuning.....	28-8217
㊷ Cone and Voice Coil.....	02861	Volume.....	28-8217