

INCORPORATING THE PHILCO SERVICEMAN



post

PHILCO SERVICE TECHNICIAN

VOL. 2

No. 5

JUNE, 1958

OFFICIAL PUBLICATION OF THE WORLD-WIDE PHILCO FACTORY-SUPERVISED SERVICE ORGANIZATION



Service Award

Mike Viall, factory rep. (l.), presents Philco Service Achievement Award to Bill D. Reed, owner of Seattle Bendix Service, 1417 E. Pine St., Seattle, Wash., while Mrs. Margaret Reed looks on. At right is George Elliott, distributor products service mgr., Graybar Electric Co., Inc., Seattle.

For other "Field News" see . . . Page 3

PHILCO SERVICE TECHNICIAN

JUNE, 1958

VOLUME 2

NUMBER 5

Official Monthly Publication of, by,
and for the world-wide Philco Factory-
Supervised Service Organization.

RICHARD A. PHILLIPS Editor

Philco Service Technician is published
by Philco Corporation. Material con-
tained herein cannot be reproduced
without written consent of the pub-
lisher.

Address Correspondence to:
"PHILCO SERVICE TECHNICIAN"
PFSS Headquarters
2nd and Westmoreland Sts.
Philadelphia 40, Pa.

POLICY . . .

Philco Service Technician will strive to
"mirror" the activities of the thou-
sands of PFSS members and to
provide them with useful and helpful
information.

GOING THE ROUNDS WITH UNCLE PHIL

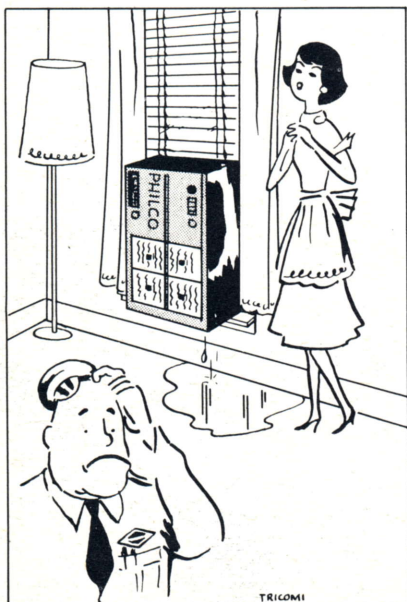

"My husband installed it, but there
seems to be something wrong."

THE Editor's WORKSHOP

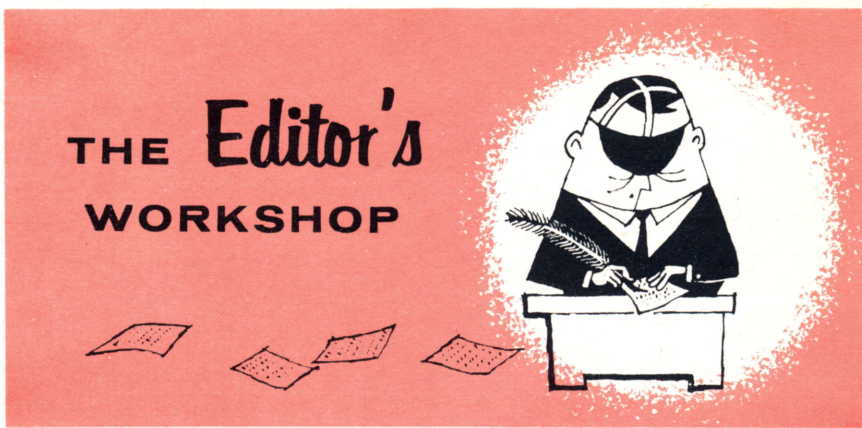

Hi fellas! As individuals, it may sometimes seem that our personal opinions don't count. This is not so.

It's true that a lot of individual opinions that are the same can be a greater force than a single one, but *each one counts!* For instance, you may feel that income taxes are too high and that there's nothing you can do about it. Actually, if you were to write your Congressman to express your opinion, it could make a difference . . . because enough individual opinions like that would be a *powerful influence*.

Sometimes a thought expressed by *one person* can be such a good idea that it is all that is necessary to start action. This is another reason why an individual opinion counts.

There are examples of opinions in letters written to Philco having an effect on how things are done. One such example recently resulted in a change being made in *Philco Appliance Supervisor* magazine. A number of letters were received that suggested it would be helpful if the "other side" of a page on "Refrigeration" contained the same subject,—rather than the beginning of another subject. Evidently, a number of service technicians file these articles by product category, and this was not possible when two products were on the same sheet of paper.

As a result, the matter was discussed at a meeting and a plan was designed to correct the problem.

Another example was "fold-out" schematics. There are usually advantages and disadvantages to every system, and because of certain advantages, a number of schematics were produced in the "fold-out" style. Once again, your letters said this form was not as easy to use and that you preferred the regular "page" style. As a result, another change was made due to your comments.

It is not possible, of course, to follow every suggestion received. Many times there are reasons not known to an individual why certain things cannot be done, but this fact should not deter anyone from expressing an opinion. This situation sometimes applies to the Monthly Award letters. There might be a case of a servicing idea that has merit . . . however, if there is a standard recommended procedure already in existence, the idea cannot be given an award. Other examples of this may involve one specific brand name servicing tool, for instance—and one specific brand cannot be featured without casting a reflection on other brands. So, you can see there are many factors that must be considered.

Business, government, or any organization will almost always consider suggestions or criticism. And opinions can be expressed on things you favor . . . it's like casting a vote. So, when you have a definite opinion about anything that affects you, remember to write about it—it makes a difference.

Field News

NEWS ABOUT
PEOPLE AND EVENTS
IN THE SERVICE WORLD



EAST HARTFORD, CONN.

Roskin Distributors Inc. held an electronics service training meeting Feb. 5, as reported by factory rep. Ed Burke. Approximately 230 service technicians attended the meeting (see picture on this page). Distributor general service mgr. Max G. Frankel and factory rep. Burke conducted the meeting.

Following is a list of those who attended the meeting:

Bill Krisnow, Tom Cullen, Frank Silverman, Bill Hodgins, David Pacholski, Roland J. D'Amato, John J. D'Amato, T. W. Allaire, Joseph Diprete, George Panucci, Richard W. King, EZ Television, Angelo Sabini, Leo Demorad, Ted Patterson, Edward Woodruff, Nick Barraco, Howard Loeffler, Gerald Miller, B. Rubin, Eldon P. Adair, Howard Keller, Donald Pickrell, Arthur Cicerchia, Stanley Waluk, Royce Whitcomb, Redford L. King, Bruno Chiarella, Gregory Chiarella, Robert Gordon, Robert Bellemare, A. Borer, Emil R. Blau, Bob Werfelman, Richard Grossi, Brad Hurlburt, Fred Simboski, Winston Robertson, Charles Murkovicz, William Wityok, Arthur Van Sicklin, Henry Rossi, Bill Eckert, Morris Polansky, Edward Beaudin, Al Rosenfield, Charles Blake, H. D. Kimball, Ralph W. Cote, Max Blumenthal, Joseph Liyana, Fred Semolic, John Urban, Jerry Beccia, Karol Bulat, Edward Kuhn, Edmund Rogers, W. Scapini, W. R. Shook, Lou Strong, Don Klanko, Lionel Gadoury, C. Zarco, John Mikotkowski, Henry L. Robert, Stanley Wilk, Carl Carlson, Edward Ostrowski, Robert Shaw, Joe Scialla, P. E. Cummings, Kenneth Anderson, Ed Belcher, Wm. Middlemass Jr., and . . .

Frank Bendzinski, Wm. Ousterhout, Gail Margle, A. Imperete, Peter Zuk, W. T. Edmonds, Norman Smith, Jack Jenkin, Paul Cardalico, Howard Schortman, Bob Bousquet, Frank Kli-siewics, Edward Kuhn, Joseph Ford, Edwin Cohen, Bill Cotner, Emil Blau, George Routhier, Richard Hatt, Joseph Bitondi, Wilbur Hills, Joseph Chicoine, George Diegel, John Malone, Robert Snow, Eddie Bagot, Poreus Jardo, C. J. Killemanx, Albert Jordan, Goucher, Daniel Springel, Jerry Martin, Norman Preuss, Louis Grasco, Robert McMahan, Milardo's Radio TV, Ed Sendek, Michael Wowk, W. Lamoureux. G.

B. Clarke, Andrew Kuctimtis, W. Bullard, Stanley Backus, John Koanz, Richard Whalen, Herman Kuklinsky, Sidney Starr, Garfield Johnson, D. Gormley, E. Rietz, David Angell, Walter Bayer, R. Davich, Anthony Roscello, Stephen Dzwonchyk, Rubin Greenbaum, George Kravac, Tony Mica, Albert Morelli, Henry Gonder, Mike Garcia, John Swenson, E. W. Long Inc., James Hagopian, Al Groce, H. S. Roosevelt, D. Belmonte, Nick Buonocore, Anthony DeLorso, Edw. Kruzel, Wm. Kowalczyk, A. Cook, Valentino Pattavina, H. F. Taylor, John Almeida, J. L. LaHattino, Jack Nidriger, B. J. Fisherman, M. Garber, Eugene O'Brien, Henry Cook, Luth Rose, Chester Slepiski Jr., and . . .

Hugo Gerber, Marvin Baltimore, Sal D'Addio, Sam Guccavidi, Read's Radio & TV, Phil Gottoranto, Carl Clarkson, Tom Moran, George Hatch, John Kiese, Michael Melchan, Benjamin Monstrunt, Ed Wakelee, Thaddeus Gryvace, Robert Shavor, John Jaceiuz, Edward Michaluk, Peter Miscils, S. R. Parker, Henry Russell Jr., Jos. Dito-maso, Walter Lankowski, W. E. Bushnell Jr., Samuel Kohn, Frank Adams, Basiel Electronics, Edmund Sweeney, Bill Emery, Walter Hendrick, Leonard Androphy, Wm. Zurick, Edw. Truelove, George Knowlton, Pat DiGiro, Robert Keller, E. Rogers, John Colello, Robert Salisbury, Donald Dunn, R. F. Bonney, Frank Carpenter, Al Androphy, Robert Avakian, Silas Hill, B. Maliga, Sam Rosen, Bill Sokol, Bill Cardell, and Art Hill.

ATLANTA, GA.

A series of electronics service train-



General view of the electronics service training meeting held by Roskin Distributors Inc. on Feb. 5. Distributor general service mgr. Max Frankel conducts training. (See story on this page.)

ing meetings was held by Brown Distributing Co. in Feb., as reported by factory rep. L. P. Kull. Following are lists of those attending:

(Feb. 13—Macon) T. E. Elliott, J. Earl Thompson, Allen J. Gibson, Emmitt Deal, John Smith, H. L. Anderson, Bob Free, Neal Kitchings, Curtis Hitchcock, C. E. Causey, W. D. Best, H. R. Gordon, Richard Knight, Robert Johnson, Jas. Prevatt, Ralph W. Carr Sr., Grady Mask, R. O. Hattaway, Richard Ganet, Emmett T. Bragg, Harris Bragg, Eugene O. Raynor, Hugh Banks-ton, M. Scarborough, H. J. Howard, Oscar L. McDuffie, Curtis Nibbert, J. J. Higgison, John Dixon, Joe King, H. L. Brown, William Brown, and H. L. Wynne.

(Feb. 17—Augusta) James E. Snider, J. Clair Day, Allen Wren, H. H. Parker, G. W. Johnson, J. W. Minchew, M. E. Miller, T. Wendt, C. W. Burrum, Ronald Whitlaw, Ben R. Whitlaw, W. C. Johnston, Marvin Holley, Smitty, Ed. Anthony, Ed McCoy, Bill Gammon, Ed Lee, Bill Oxner, J. W. Spratlin, Joe Scott, Mr. Cason, Bill McClearn, Jay Calliham, and Jack Rogers.

(Feb. 18—Anderson, S. C.) Calvin Cannon, Leon Suttles, O. A. Madden, Hubert Allen, Ray Whitworth, W. G. Cromer, Joe B. Higginbotham Jr., Thomas Carey, I. N. Ray, J. B. Hilley, Dunn TV Service, Olin T. Jaynes, Howard Carroll, Mack Brown, Paul Brown, Joe R. Fortion, Frank Threlkeld, and J. B. Martin.

(Feb. 20—Columbus, Ga.) Herbert J. Bagley, Seth Poole, Normand Shropshire, Herschel Melvin, Russell Thornton, Ruel Waldrop, J. A. Eady, H. C. Hogencamp, W. H. Hogencamp, Ted Inyrom, and Clarence R. Wilkerson.

BURLINGTON, VT.

Vermont Appliance Co. held two electronics service training meetings, as reported by factory rep. Ed Burke. Following is a list of attendance of each meeting and the dates on which they were held:

(Feb. 25—Windsor) Albert A. Prevo, C. Thurlow, George Pringle, Paul Blanchard, L. J. Moore,

(Continued next page)

Field News

(CONTINUED)



W. E. Bloomfield, Roy Hastings, Aaro Kashi, Clarence Prevo, Sidney Lane, Edwin E. Maynard, Ralph W. Jefes, William Copeland, and Paul Revere.

(Feb. 26—Burlington) A. P. Mason, Arthur Stewart, J. L. Ploof, Paul Diette, George Guillet, Richard S. Egan, Harold L. Coan, David E. Bonnette, Calvin Morgan, John L. Bartlett, Lewis A. Williams, Clyde Stannard, Gerald W. Gallison, E. J. Callette, Byron G. Gallison, Charles J. Sanders, Gerald Jourdan, George D. Ward Jr., Earl Gove, Wendall Walker, M. L. Gilbert, Maurice Bell, Reginald Libbey, Paul Wagner, Carl E. Paquette, Vincent Bell, Henry R. Fogg, Lucian J. Goulett, Harvey B. Clark, Jerry's Appliance, Conrad Alarie, Milo Nelson, Winston Munson, and Lionel Lavalley.

PORTLAND, ORE.

Graybar Electric Co. held a series of home laundry service training meetings in Feb., as reported by Philco factory rep. Mike Viall. Following are lists of service technicians in attendance, and the dates of each meeting:

(Feb. 24—Portland) Raymond Sullivan, Bob Proffitt, Lawrence Beedlong, Norman Dyck, Victor Dyck, Frank Snider, Dave Neururer, Dick Leuy, H. Jones, R. A. Freitag.

(Feb. 25—Portland) Irving Besserman, Max W. Winder, Ken Wingard, G. E. Jolma, James Crockett, Harvey Ran, Bill Jones, Jack Spellmeyer, Joe Baker, Shorty Taulbee, Ralph Stinson, and Sam Stinson.

(Feb. 26—Hood River) W. C. Ogden, Marty Ekker, Eugene Harvey, Laren Culp, Craig Mayfield, Everett Davis, Mark Hilton, Bob Kennedy, W. F. Larson, and Ted Hackett.

(Feb. 27—Prineville) Hal Flora, M. L. Janes,

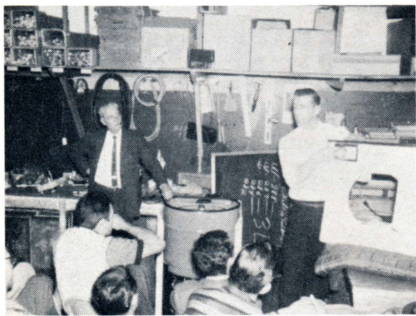

Ole Olson and Herman Wagner of California Electric Supply Co., San Francisco, conducting home laundry service training meeting in Sacramento on Feb. 20. (Story begins on next page.)

Dan H. Heierman, Dick Vian, Art Labrousse, Al Alderson, Jack Kaines, Jack Donnelly, W. E. Johnson, and C. S. Trout.

CHARLESTON, S. C.

Brown Rogers Dixson Co. of Columbia held an electronics service training meeting Feb. 27, as reported by factory rep. Len Hardin. 21 service technicians attended the meeting. Following is the list of attendance:

John H. Langston, Ernest Deery, Ray J. Hill, James C. Teston, Claude Esting, Cecil Carr, B. R. Dickens, John Wheeler, Abram O. Cinechy, Jerry Smighton, George Marlowe, M. D. Smith, M. Arthur, Robert Kleinkopf, F. C. Walker, C. B. Inahett, P. E. Waldridge, Lynn R. Shutt, Al Gobel, E. P. Chiola, and L. A. Wirth.

BOSTON, MASS.

L. B. Lind, service mgr. of J. H. Burke Co. announced a series of Philco-Bendix service "clinics" to be held, the first one being scheduled for Feb. 25 and covering Duomatics. Refreshments and door prizes were planned as added attractions.

SALT LAKE CITY, UTAH

Strevell-Paterson Hardware Co. held a series of electronics service training meetings and school as reported by Philco factory rep. Walter Kembel. Following are the dates and descriptions of the various meetings:

(Jan. 14—Delta) Electronics service training meeting with 6 men in attendance.

(Jan. 15—Filmore) Electronics service training meeting at dealer Kimballs Inc. with 3 service technicians in attendance.

(Jan. 16—Cedar City) Electronics service training meeting held at dealer Northeast Furniture with 8 technicians in attendance.

(Jan. 17—St. George) Electronics service training meeting held at dealer Pickett Lumber with 5 service technicians in attendance.

(Jan. 29—Evanston, Wyo.) Electronics service training meeting held at dealer Emerson Bros. with 7 men in attendance.

(Feb. 5—Salt Lake City) Electronics service training meeting held at dealer Z.C.M.I. Radio Shop, well attended.

Philco Speakers at NARDA

Two representatives of Philco Corp. were speakers at the School of Service Management held Mar. 26-28, by NARDA (National Appliance and Radio-TV Dealers Association). They were John Bennett, mgr. of Philco Factory-Supervised Service, and William J. Nagy, general sales mgr., Accessory Division.

The school was held at Northwestern University, Chicago, Ill., and those attending came from 50 cities and 27 states. One of the aims of the program was to provide possible answers "to the criticisms that have been leveled at service in the Nation's consumer press in recent months."

(Feb. 11—Salt Lake City) Electronics service training meeting held at dealer Boyers Radio & TV, well attended.

(Feb. 24 to 28, and Mar. 3 to 7—Salt Lake City) Electronics service school on black and white television. This was an 80-hour course attended by 5 service technicians. These technicians were from Utah, Wyoming and Nevada. Their areas have just opened up using the translation systems on UHF.

(Mar. 14—Salt Lake City) Electronics service training meeting held at dealer South East Furniture Co. Well attended.

(Mar. 21—Salt Lake City) Electronics service training meeting held at dealer Radio Television Service Engineering. Well attended.

JACKSONVILLE, FLA.

The Parts and Accessory Mgr. at Empire State Distributor Inc. now is Don Pitts.

EL PASO, TEX.

Crouch Appliance Co. held an electronics service training meeting on Mar. 4, as reported by factory rep. Ted Roberson. Attendance was 6.

HUNTINGTON, W. VA.

Tri-State Appliance Co. held an

Field News

(CONTINUED)



electronics service training meeting on Mar. 5, as reported by Philco factory rep. Roy A. Gumm Jr. 38 service technicians attended.

Three door prizes were awarded. Mr. John W. Lawson won first prize, which was a gold watch. Each service technician received a package of resistors and condensers, and a Service Reminder book.

Following are the names of those in attendance:

Sam Brickley, Lawrence Nicholas, Bruce Seafiler, William Davies, Fred Abbott, Ben DeRond, Paul Martin, James E. Adkins, John Adkins, E. L. Goldcamp, J. M. Boggs, C. W. Terry, W. D. McFann, Robert Cameron, Charles Seaman, Leo Levey, Dave Murphy, John W. Lawson, Paul Lynd, K. M. Schafer, Bill Legg, Modesto Rodighiero, Johnnie Stevenson, Roger Phillips, Norman Sprodling, Floyd Warrick Jr., Ezra Ward, R. S. Wood, Billy Miller, J. O. Ballard, A. R. Dilley, T. E. Sheets, Charles Maynard, Steve Toth, W. F. Queen, Clyde Watts, L. B. Foreman, and William Gay. Hennie Watts, distributor electronics serviceman, also attended.

COLUMBIA, S. C.

Brown Rogers Dixson Co. held an electronics service training meeting Feb. 26, as reported by factory rep. Len Hardin. Following are the names of 34 service technicians who attended:

Denley W. Jones, G. C. Kennon, J. L. Chambers, Frank R. Powell, Ernest F. Schwach, C. O. Nunnery, H. W. Hall, John Kessler, E. E. Price, Earl Jackson, Ki Summer, John Harper, Buddy Rast, Bill Hilliard, Ray Kitchen, Edw. Lomack, Herman Nallz, P. J. O'Neill, H. L. Nye, N. R. Austin, J. E. Amick Jr., Rudolph Hatcher, Chas. W. Davis, Wm. W. Frawley, D. C. Francis, L. Ferguson, Roy Porter, Joe S. Melton, J. E. Hall, Bill Rivers, Ray Keisler, Harold Deason, W. G. Wilson, and E. D. Young.

LONG ISLAND CITY, N. Y.

At Philco Distributors Inc. Bill Messick is now general service mgr., with D. Sabatini as electronics service mgr., P. Polagye as appliance service mgr., and Jack Ryman as consumer service supervisor.



A Philco Service Achievement Award was presented to Art Packard of Art Packard Radio & TV Service, El Paso, Tex., on Mar. 4. Shown above (l. to r.) are Ted Roberson, Philco factory rep.; Fred Hudson, sales mgr., distributor Crouch Appliance Co., El Paso; Art Packard; Paul Juen, distributor general mgr.; and Bob Williamson, distributor parts and service mgr. Mr. Packard says he built his first radio six months before President Wilson died. He has been in business since 1929 and a Philco serviceman and dealer for almost 30 years.

SAN FRANCISCO, CALIF.

California Electric Supply Co. held a series of home laundry service training meetings in Feb. and Mar., as reported by Lee Bird, Philco factory rep. The meetings were conducted by Herman J. Wagner and Oris Olsen, distributor field engineers. Following is a list of the attendance and the place where the meetings were held:

(Feb. 19—Chico) Jim Dobbs, Gus Anglis, Walter Myrick, Phil Alfis, Ira Urquhart, J. Hardy, W. A. Nield, Russell Davis, W. R. Bowles, C. E. Ulgman, J. M. Biggs, M. Clewett, Vincent Moore, Allen T. Vrick, S. G. Dever, Bob Moreau, Jack Small, H. L. McCrary, D. L. Baxter, Pete Peterson, Ray Wallace, Wallace Naye, Alan Colburn, Bill Kuppe, Carlo J. Albonico, V. G. Polouc, Tom Jones, B. B. Carter, Pat Coleman, R. C. Wilson, Earl Whipple, and Jack Tappendorff.

(Feb. 18—Redding) W. Barlow, C. F. Gower, D. G. Pellow, W. D. Boatrun, M. Mash, Rolla Houston, Jack Adams, Bob Spam, Bill Pump, Fred H. Mahnes, Tex Gibson, and Phil Alfis.

(Feb. 20—Sacramento. See picture on page 4). Leslie P. Gillett, Hazen Simkin, Bob Fong, Ray Elwell, Jess Hudson, Archie Fynn, Richard Wyatt, Raymond Elwell, Ernie Baldwin, Don Whiting, Don James, E. T. Chappell, Al Gerard, R. A. Muff, John D. Hutchinson, C. Huft, J. W. Voss, R. Voss, Art Keck, Tealon McGhee, Ed Doddon, B. C. Minehan, Lloyd Maticiant, W.

Bienefeldt, Fred Luzzi, Lee Williams, John Weinbergh, Edward Jow, Bob Nachtrab, O. L. Shepherd, K. H. Kreionsieck, E. D. Finnestead, Art Fong, Roy Uda, W. Reich, McCormick, J. H. Schwartz, E. G. Schlenken, D. E. Walden, and C. P. Rich.

(Feb. 10—San Francisco) E. R. Davis, Erwin Davis, Chesley Harris, Lynn Parker, Lenev Hada, George Hammen, Milt Stamate, Albert Everhard, Eugene W. Larsen, Al Blackeniche, C. Ellis, Wm. Medd, C. Robertson, Russ Seyfertt, Al Halben, C. Goldman, R. Sims, H. R. Robert, Bud Kiefer, M. Dunleany, A. MacMillan, Edwin Stone, J. Mazzonucci, Roy Sankey, S. Guseo, E. Berone, Gard Neubert, Les Gregory, S. McQuin, Jerry Maurer, Seth Casini, Douglas Scott, A. S. Webig, Ray Poole, J. Donnell, J. Wilson, J. Randall, M. O. Fendner, and Joe Valenson.

(Feb. 12—San Francisco) Vick McCurry, Jack McCurry, Rudy Pavlik, M. Farmer, Hugh Sykes, Jim Stout, Eddie O'Brien, M. Marquis, Danny Barber, Jack Donohoe, Lee Lipska, Andrew Boxes, C. Petty, Ralph Gorer, D. A. Bruce, Guy Tal, Pat Schevig, Lou Proto, J. Kal, Tom Carney, C. Ward, Larry Doyle, Walter Ceremony, Eddie Gamba, Bill Quefey, Don Marosy, Harry Outlud, Sim Seiki, John Mori, Toy Laurila, T. F. Thoney, R. A. Birdsall, J. V. Hedge, and Lee Bird.

(Feb. 13—San Francisco) Ray Bohanan, J. Costtele, W. Halych, F. Blucher, J. Wright, Joseph Vecchio, Edward E. Gould, B. Sullivan, Lee Baxter, L. Venable, C. J. Cunningham, A. Henoki, George L. Faucett, Jack Tahara, R. Ochita, L. Peipley, F. Kilburn, Walter R. Rava, George Davis, Ronnie Husk, John Nendza, Fred Benart,

Field News

(CONTINUED)



Speedway, Odis Brackett, Bob Cantua, Joe Car-doon, Norm Palmer, Bob Heighway, Dale Allen, J. R. Nielsen, George Lee, Gene Lee, Otto Fusaro, Ronald Pello, Sam Moulton, Mannie Closery, R. L. Kaiser, W. Caseella, O. Peterson, and Lee Bird.

(Feb. 26—San Jose) William Vickrey, E. Eddy, C. Guzeh, Al Termer, Al May, Don Yort, Aen Otten, Paul Brohmer, Ed. Eplen, C. J. Chapway, Joe Fenton, W. Piper, N. C. Slusher, Bob Turner, E. O'Mara, T. Bailey, George Holt Jr., J. M. Whittard, Leo J. Holt Sr., A. B. Givens, Joe Andre, Tom Barron, Rod Lane, Al Streeght, Bill Pearson, David Pariatt, Elmer A. Schmidt, Wal-lace Leslie, Frank Da Kosa, John W. Bembl, Don-ald E. Cloud, M. de Lean, Warren H. Gist, Vern M. Huck, William Ludwig, Elmer Tiseth, Rudy Uribe, Bill Shioly, Bill Miller, Richard Shirly, E. F. Hayes, R. F. Scaffern, Buster Brewster, H. B. Ruz, L. J. Russell, W. Greer, Walt Pitcher, Merle Wilke, Don Cole, and Olie Richert.

(March 3—Santa Rosa) Philip L. Nielsen, Hans G. Sorensen, Bill Johnson, Dean Shito, Walter P. Hoinig, C. E. Clarke, Frank Trimelan, George Orphan, G. C. Wright, George Tucker, B. G. Brown, M. Ombaun, Jack Gillis, George Montague, Roy Kunz Jr., Lorren Huston, Chet Dutton, Frank Planer, Nick Schaeffer, Walter Tucker, Ray B. Turner, L. Stavas, E. Baldwin, N.

Thrash, Chet Talor, Jack McPhail, Harry D. Out-land, R. E. Montague, Gorky Conte, Vince Jo-seph, and Joe Graham.

(Feb. 27—Seaside) John Vollmer, Michael N. Lus, M. G. Bennett, Carl Hoegemeier, Stan Drake, Don Christenberry, Jack Mero, Dale J. Stoolley, Bob Anderson, Larry Lloyd, Pat Smith, Bob Hyland, Dave Dickinson, Joe C. Waag, Alirno Ramirez, Joe Ramirez, Ray Perez, J. H. Gledhill, and N. L. Moore.

(Feb. 24—Stockton) Joseph L. Belt, Whomous Kjera, Howard McGlothlin, Erwin Rahe, Jim Al-len, C. E. Pistorius, Donald Duvel, Les Espinoza, Mike Burke, Bob Pernicci, Chas. Morows, Daul Parqueta, Emil Brenner, A. S. Skaggs, Joseph M. Steiner, J. Acker, Frank Kastell, Don McKee, Dante, Conepa, Earl H. Meyers, Gilbert Cruz, Max Sorra, Howard L. Bennett, Ernie Haggren, Mike Matsel, Holden, Al Morehouse, George Pemberton, Loren F. Wright, and Kenneth E. Hall.

NASHVILLE, TENN.

Currey's Inc. announces that the Parts and Accessory Mgr. is Mr. Leon C. Hinkle Jr.

WINSTON-SALEM, N. C.

Butterfield Inc. held an electronics service training meeting on Mar. 6, as reported by Len Hardin, Philco factory rep. 51 service technicians at-tended. (See picture this page.) Door prizes were awarded by a drawing at the end of the meeting. First prize was a Philco Volt-Ohmmeter, second prize a Stanley Executive Tool Set.



Two views of the electronics service training meeting held by Butterfield Inc. on Mar. 6 at Winston-Salem, N. C. (See story on this page.)

Following is a list of those in at-tendance:

D. W. Scott, F. E. Cecil, Steven C. Holland, W. J. Dillon, E. L. Boyd, C. W. Reece, W. P. Cartrette, B. D. Moorefield, M. D. Tedrow, Dick Tamer, C. M. Pardew, David T. Drage, V. L. Dil-worth, H. L. Carither, J. M. Slate, Dennis Don-ardt, J. Lee Martin, E. J. Mason, J. F. Cathey, Victor Good, Jimmy Vanhoy, W. T. Livengood, W. H. Fine, Ed Hill, Jim Hornady, Robert Steel-man, Tommy Smith, Riley Wood, Dudley F. Phil-lips, C. W. Pitts, Ralph Thompson, Harold Grubbs, Allen White, Franklin M. Collins, Wil-liam M. Cardwell, Otis Beasley, Harvey Hicks, Bill Blair, Vic Ross, Billy Melton, E. L. Swaim, D. G. Lambeth, R. B. Johnston, M. A. Andrews, G. T. Howell, W. F. Lanning, F. D. Swing, W. F. Covington, E. C. Todd, L. P. Stowe, and William M. Lapish.

BALTIMORE, MD.

Legum Distributing Co. held re-frigeration service training meetings on Mar. 11 and 12, as reported by H. W. Johnson, Philco factory rep. (See picture this page.) The topic covered was motor compressor changing in automatic systems. The school was conducted by Bill Bern-inger, of factory service headquarters. The following are the lists of attend-ance at both schools:

(Mar. 11—attendance 10) William Dubert, Jack Anderson, Ray Helinski, James Smith, George Krupinsky, Joe Weinkan, Bernie Wor-rell, John Devoto, John Radic, and Edward Anderson.

(Mar. 12—attendance 16) J. R. Fritts, Russel L. Bery, Bill Giffit, E. Barthlon, Eugene Kief, W. L. Speiker, D. E. Goodwin, James McQuade, Paul Dentler, Ralph Weaver, William Dix, Joseph Szukanty, Bill McMillan, William Gross, George L. Bartlett, and James Martin.



Two meetings are pictured here. Top photo shows assembled servicemen at refrigeration service training meeting held by Legum Distributing Co., Baltimore, Md., on Mar. 12. Bottom photo shows servicemen who attended meeting on Mar. 11, also on refrigeration. (See story on this page.)

Better Business

... A SERIES ON IDEAS AND METHODS FOR EFFICIENT BUSINESS OPERATION

III. How to Bill the Customer

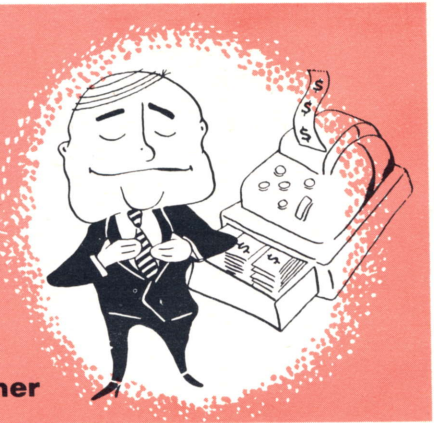

Did you ever have a customer complain about a service bill? Most service technicians have, but there's a way to eliminate most of the complaints.

The secret is to ITEMIZE the bill—the parts, labor, tax, and the description of the work you've done. Most customers won't complain if they understand *what they're paying for*.

To go to the opposite extreme, the customer gets a real shock if you hand her a bill like the one illustrated here:

May 14, 1958	
Mrs. John Doe	
100 Main St.	
Yourtown, U.S.	
For service rendered	\$12.50

A shock-producer.

Who wouldn't? The bill doesn't indicate any of the work that's been done. And, when the husband comes home that night, how will she be able to explain to him what you've done to justify that bill?

To keep satisfied customers, it is much better to take a little extra time to *itemize your charges* on the bill. Did you ever take your car to an automobile service agency for a repair job? Maybe you were handed a bill of \$72, but chances are that you had no argument because the total was itemized

in amounts of a few dollars each—and you couldn't find fault with any one of them.

The charges on the bills that you write for customers should be covered in five basic "categories":

1. Description
2. Parts
3. Labor
4. Tax
5. Total

Description. This is where you can list every part of the job you did, including any checking or extra services you performed.

Parts. List each part used, with a separate price for each one. Describe the part so that the customer will know what it is. For instance, instead of writing "1-6BQ7," describe it more fully as "1-6BQ7 tube."

Labor. Charges for labor may be listed in one or more ways... you may charge a specific fee for the serv-

ice call, or you may charge on a time basis. A "pick up and delivery" fee may be listed as a separate item on jobs taken into the shop. The more that labor charges can be itemized, however, the more justifiable they will seem.

Tax. State or local taxes will be a separate listing in areas where they apply.

Total. With the itemization you have made, the total no longer will appear to be an arbitrary amount to the customer, and collecting will be an easier job.

Let's take a look at how a bill might appear when these principles are put into practice. The illustration (below) is for a solenoid and belt replacement on a washer, but notice the *itemization*.

One more "follow through" detail is to explain the bill to the customer when presenting it, and add a comment of "you may want to check my addition to be sure it's correct, Mrs. Doe." This comment (suggested in "Customer Psychology," Aug., 1957, PST) will "get the customer into the act" and into a position of "okaying" the charges.

Use a printed billhead, with your name on it, to make an impression of business reliability, and *take time to itemize*.

DESCRIPTION		
	Replaced burned out pump solenoid.	
	Replaced badly worn drive belt.	
	Drained and changed transmission with fresh oil.	
	Checked and cleaned drain screen & housing.	
	Checked fill time and water level.	
	Checked timer through cycle.	
PARTS		\$
1	# 9536-5 pump solenoid	3 45
1	# 9040-12 drive belt	3 15
11	oz. transmission oil	50
LABOR		5 50
<input checked="" type="checkbox"/>	Service Call	
<input type="checkbox"/>	Pick Up and Delivery	
<input type="checkbox"/>	Extra Labor: _____ hrs. @ \$ _____	
	TAX	21
	TOTAL	<u>\$ 12 81</u>

Itemizing charges makes the bill more palatable.

MONTHLY Awards

For promotions, trade tricks, time savers, business ideas

\$10.00 AWARD

"To replace riveted-in components in many sets, particularly portables, it's sometimes very difficult to reach all mounting holes with nuts or screws to mount a new part. Try tacking the nut or screw to the new component part with solder before placing it in the hard-to-get-at spots."

James M. White, White Radio Service Co.
209 Almeria Avenue, Coral Gables, Fla.

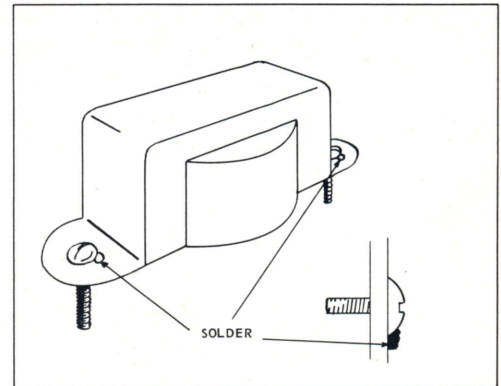

\$10.00 AWARD

"When removing old capacitors, it takes time to remove the lead wire from a terminal that may have many other wires on it. I cut the lead wire some distance from the terminal and solder the new capacitor lead wire to the remaining length of wire. Thus, there is no need to disturb the other wires attached to the terminal."

R. Waldrop, Eady Appliance Co.
Box 79, Vernon Rd., La Grange, Ga.

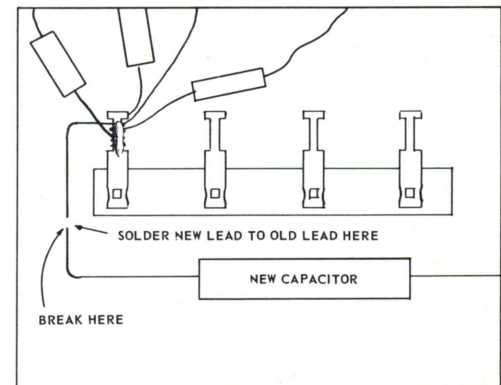

\$10.00 AWARD

"When installing a new picture tube in an old set, I often find the button-type anode plug has lost its tension. A paper clip, cut with a pair of 'dikes' and bent as shown in the diagram, makes an excellent connector. This also does away with the corona leak that so many button-type plugs will cause."

A. E. Still Jr.
305 Lamar St., Greenwood, S. C.

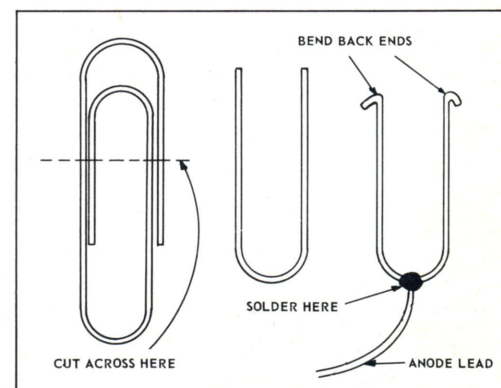

Send in your ideas . . . you may be a winner, too. It might be something you do every day . . . but it might help others. Enclose photographs if possible (or even a rough sketch) to illustrate your idea. All such ideas are to be submitted only on the basis that Philco shall have unlimited rights to the use thereof for any purpose whatsoever, free from any obligation to the sender. We will consider all suitable items.