

## Specifications

**TYPE OF CIRCUIT:** A.C. operated, superheterodyne with automatic volume control, Pentode audio output, and covers the standard broadcast and state police frequencies.

| POWER SUPPLY: |                  |                   |
|---------------|------------------|-------------------|
| Voltage       | Frequency Cycles | Power Consumption |
| 115           | 50 to 60         | 40 watts          |

**INTERMEDIATE FREQUENCY:** 470 K.C.

**R.F. TUNING RANGE:** 540 to 1720 K.C.

**AUDIO OUTPUT:** 2 watts.

**PHILCO TUBES USED:** Five: One 6A7, Det. Osc.; One 78, I.F.; One 75, 2nd Det., 1st Audio; One 41, Output, and One 84, Rectifier.

**TUNING MECHANISM:** 8 to 1 Ratio using Pulley and Cord.

**CABINET:** Type "T" and "C."

## Alignment of Compensators

**EQUIPMENT REQUIRED:** (1) Signal Generator, using a fundamental frequency range covering the tuning and intermediate frequencies of the receiver. Philco Model 077 Signal Generator which has a fundamental frequency range from 115 to 36,000 K.C. is the correct instrument for this purpose; (2) Output Meter, Philco Model 026 Circuit Tester incorporates a sensitive output meter and is recommended; (3) Philco Fibre Handle Screw Driver, Part No. 27-7059 and Fibre Wrench, Part No. 3164.

**OUTPUT METER:** The 026 Output Meter is connected to the plate and cathode terminals of the 41 tube. Adjust the meter to use the (0-30) volt scale and advance the attenuator control of the generator until a readable indication is noted on the output meter after signal is applied.

**DIAL CALIBRATION:** In order to adjust the receiver correctly the dial must be aligned to track properly with the tuning condenser. To adjust the dial, proceed as follows:

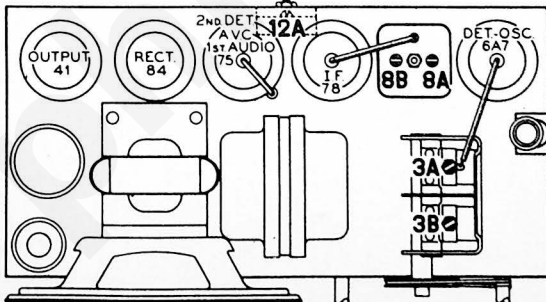

FIG. 2.—Locations of Compensators.

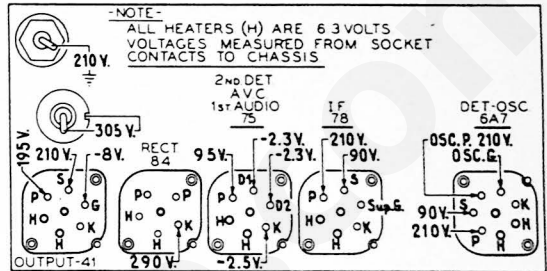

FIG. 1.—Socket Voltage—Underside of Chassis View.

The Voltages indicated by arrows were measured with a Philco 026 Circuit Tester which contains a sensitive voltmeter. Volume Control at minimum—Tuning condenser set for no signal—line voltage 115 A.C.

- 1 Turn the tuning condenser to maximum capacity position (plates fully meshed).
- 2 Holding the tuning condenser in this position, turn the pointer until it is  $\frac{1}{16}$  of an inch below the three lines of the scale at the 550 K.C. end. (See Fig. 3.) This is the correct position of pointer at maximum capacity of tuning condenser.

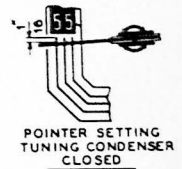

FIG. 3.—Dial Pointer Calibration.

## Intermediate Frequency Circuit

Insert the signal generator shielded output lead into the "Med." jack on the panel of the generator. Connect the other end of the output lead through a .1 mfd. condenser to the grid of the 6A7 Det. Osc. tube, and the ground connection of the signal generator to the chassis. Set the Signal Generator and receiver controls, and adjust the I.F. compensators as follows:

- 1 Set Signal Generator at 470 K.C. Turn "Multiplier" Control to 1000 and the "Attenuator" for maximum output.
- 2 Turn the receiver dial to 580 K.C.
- 3 Receiver volume control maximum.
- 4 Adjust compensators, (12A), (8B), (8A), for maximum output. If the output meter goes off scale when adjusting the compensators, retard the signal generator attenuator.

## Radio Frequency Circuit

**TUNING RANGE:** 540 to 1720 K.C.

- 1 With one end of the shielded lead of the signal generator output lead in the "Med." jack, connect the other end through a 100 mmfd. condenser to the white aerial wire (rear of chassis). Connect the signal generator ground to the brown lead or to the chassis of the receiver.
- 2 Set the controls and adjust the R.F. compensators as follows:

| Signal Generator and Receiver Dial | R.F. Compensators in Order |
|------------------------------------|----------------------------|
| Volume Control Max.                | 1500 K.C. (3B) (3A)        |

# Replacement Parts Model 38-12

| Schematic No. | Description                                     | Part No.  | List Price |
|---------------|---|-----------|------------|
| 1             | Antenna Transformer                             | 32-2583   |            |
| 2             | Condenser (0.05 mfd. tubu-<br>lar)              | 30-4444   | \$0.20     |
| 3             | Tuning Condenser Assem-<br>bly                  | 31-2068   |            |
| 4             | Compensator (Part of tun-<br>ing condenser)     |           |            |
| 5             | Resistor (51,000 ohms, 1/2<br>watt)             | 33-351339 | .20        |
| 6             | 110 mmfd. mica                                  | 30-1031   | .20        |
| 7             | Oscillator Transformer                          | 32-2586   |            |
| 8             | First I.F. Transformer                          | 32-2672   |            |
| 9             | Resistor (2 megohms)                            | 33-520339 | .20        |
| 10            | Condenser (0.03 mfd. tubu-<br>lar)              | 30-4449   | .20        |
| 11            | Resistor (40,000 ohms, 1/2<br>watt)             | 33-340339 | .20        |
| 12            | Second I.F. Transformer                         | 32-2674   |            |
| 13            | Resistor (51,000 ohms, 1/2<br>watt)             | 33-351339 | .20        |
| 14            | Volume Control                                  | 33-5230   | 1.45       |
| 15            | Condenser (0.01 mfd. tubu-<br>lar)              | 30-4479   | .20        |
| 16            | Resistor (4 megohms, 1/2<br>watt)               | 33-540339 | .20        |
| 17            | Condenser (250 mmfd.                            | 30-1032   | .25        |
| 18            | Resistor (190,000 ohms, 1/2<br>watt)            | 33-419339 | .20        |
| 19            | Condenser (0.01 mfd. tubu-<br>lar)              | 30-4169   | .20        |
| 20            | Resistor (490,000 ohms, 1/2<br>watt)            | 33-449339 | .20        |
| 21            | Condenser (0.01 mfd. tubu-<br>lar)              | 30-4169   | .20        |
| 22            | Output Transformer                              | 32-7861   |            |
| 23            | Cone and Voice Coil As-<br>sembly               | 36-3981   |            |
| 24            | Resistor (70 ohms, 1/2<br>watt)                 | 33-070339 | .20        |
| 25            | Resistor (250 ohms, 1/2<br>watt)                | 33-1259   |            |
| 26            | Condenser (Electrolytic 4<br>mfd.)              | 30-2236   | .90        |
| 27            | Field coil assembly (not<br>supplied; see Note) |           |            |
| 28            | Condenser (Electrolytic 12<br>mfd.)             | 30-2235   | 1.20       |
| 29            | Power Transformer (115V,<br>50 to 60 cycle)     | 32-7826   | 3.00       |
| 30            | Condenser (0.01 mfd., .01<br>micro)             | 30-2068   | .30        |
| 31            | Pilot Lamp                                      | 34-5068   | .12        |
|               | Bezel and Glass Assembly                        | 40-6158   | .01        |
|               | Bezel Clamp                                     | 28-5153   | .01        |
|               | Bracket (Tuning Con-<br>denser)                 | 28-5060   |            |

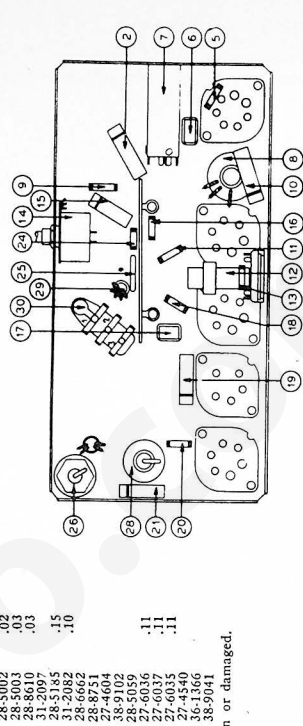
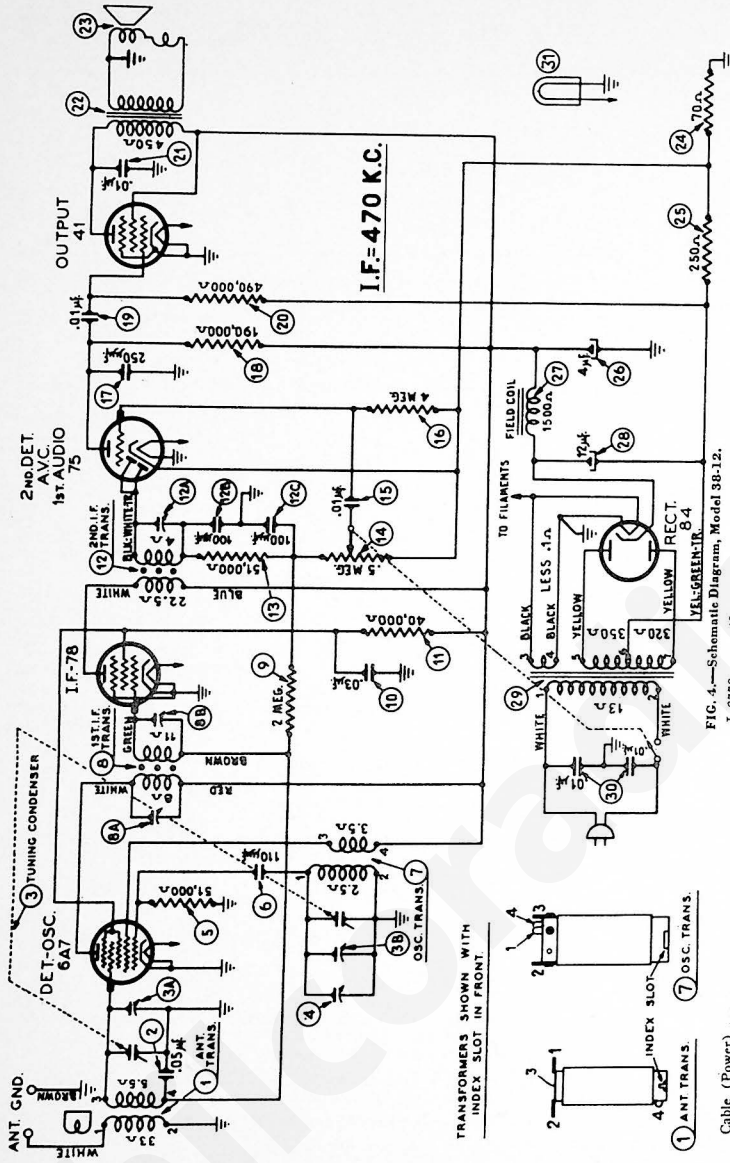

FIG. 4.—Schematic Diagram, Model 38-12.

|                          |         |     |
|--------------------------|---------|-----|
| L-2778                   | .40     |     |
| Clip (R.F. Trans. small) | 28-5002 | .02 |
| Clip (R.F. Trans. large) | 28-5003 | .03 |
| Clamp (Caming Shaft)     | 28-8610 | .03 |
| Dial Assembly            | 31-2097 | .15 |
| Dial Pointer             | 31-2097 | .15 |
| Dial Drive Cord Assembly | 31-2082 | .10 |
| Dial Drive Drum          | 28-6662 |     |
| Knob (Tuning Volume)     | 28-8751 |     |
| Knob (Tuning)            | 27-4604 |     |
| Shield (Tube)            | 28-5159 |     |
| Socket (6 prong)         | 27-6036 | .11 |
| Socket (7 prong)         | 27-6037 | .11 |
| Stop-Rubber              | 36-4035 |     |
| Speaker Model BO-1       | 36-1366 |     |
| Pilot Lamp Assembly      | 38-9041 |     |

# PHILCO RADIO AND TELEVISION CORPORATION

## Parts and Service Division

### Philadelphia, Pa.

FIG. 5.—Part Locations Underside of Chassis.

Printed in U. S. A.