

MODELS 41-250  
41-255

PHILCO RADIO & TELEVISION CORP.

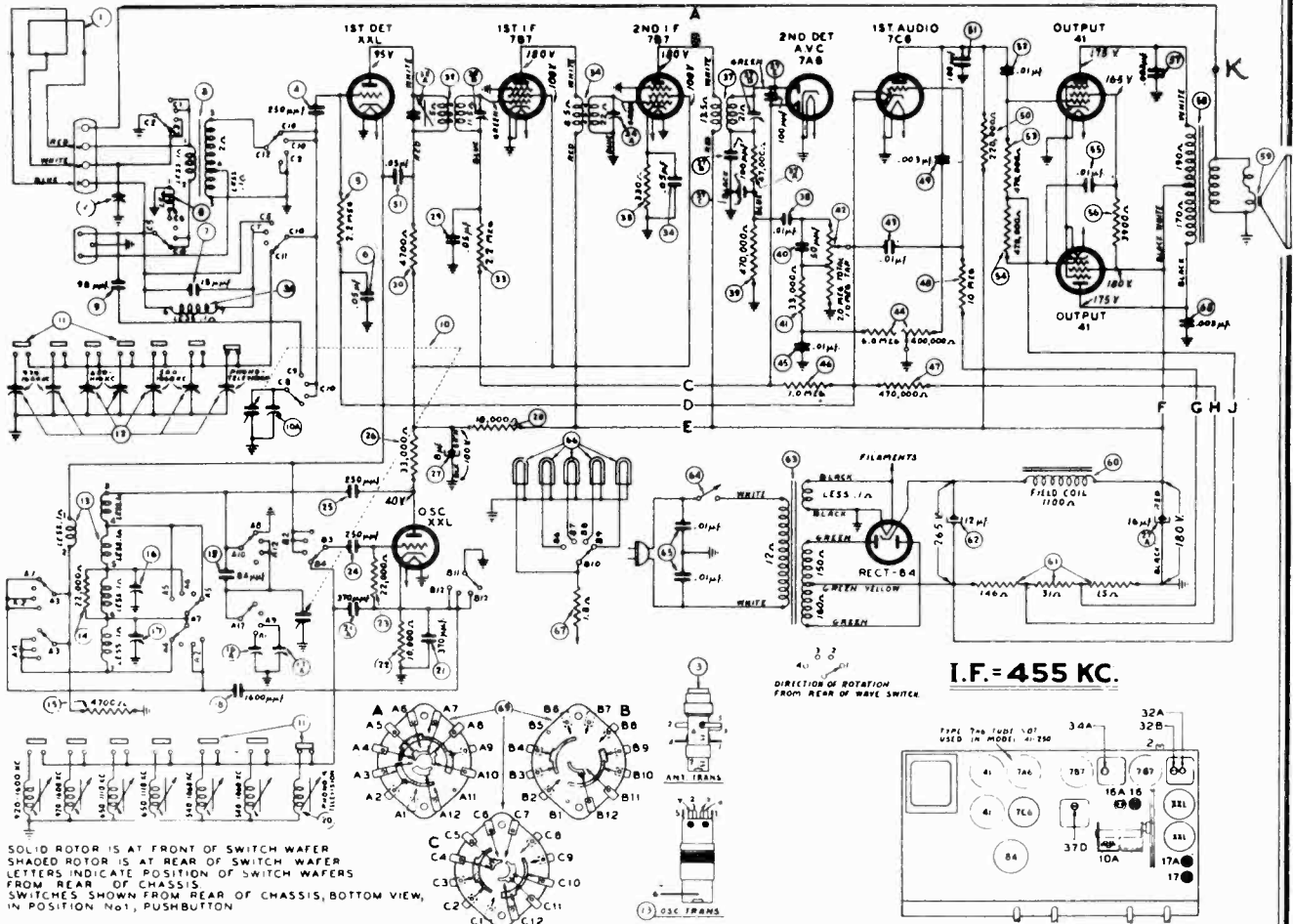

FIG. 1 — SCHEMATIC DIAGRAM — MODELS 41-250, 41-255

The above diagram is the complete electrical circuit for Model 41-255. The same general circuit is also used in Model 41-250 with the exception of the 2nd detector, 1st audio, A. V. C. wiring which is shown in Fig. 4.

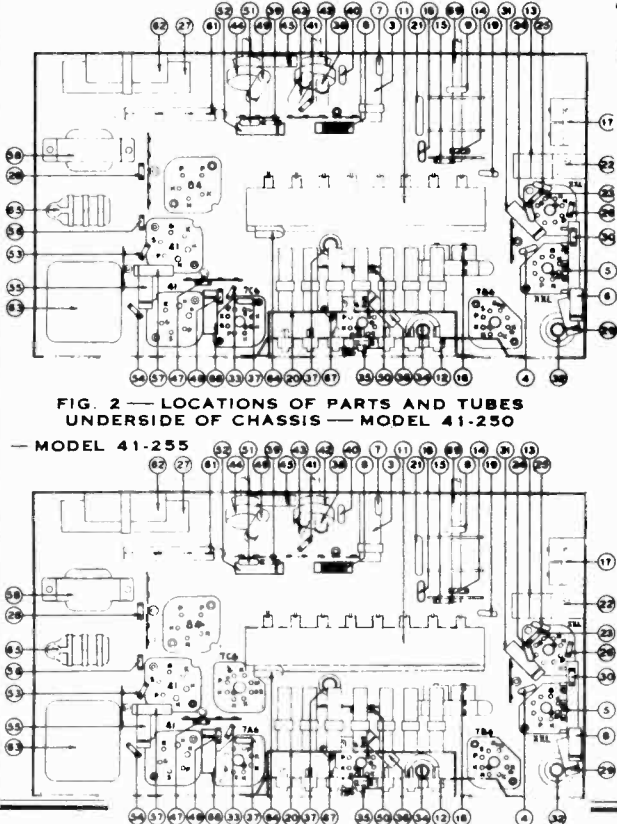

FIG. 2 — LOCATIONS OF PARTS AND TUBES  
UNDERSIDE OF CHASSIS — MODEL 41-250

— MODEL 41-255

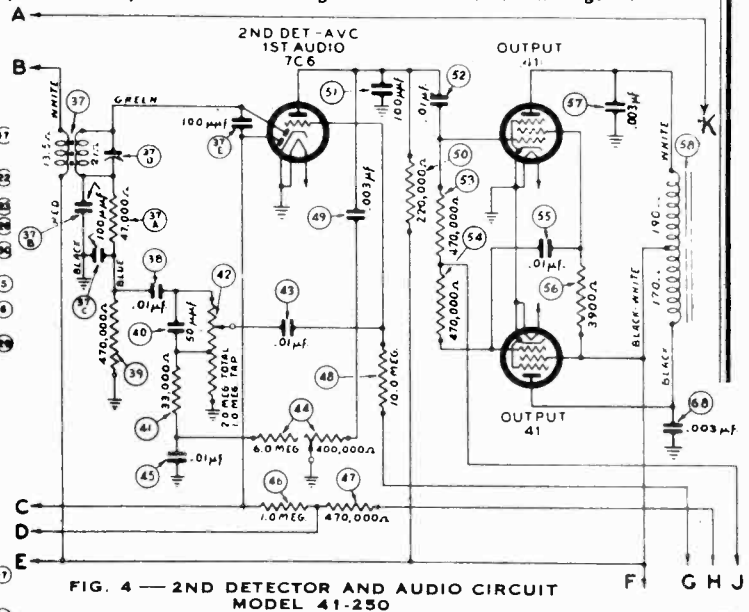

FIG. 4 — 2ND DETECTOR AND AUDIO CIRCUIT  
MODEL 41-250

FOR ALIGNMENT  
AND TUNER  
SEE INDEX

JUNE, 1940

