

# Instructions for RCA Victor R-73 Radiola

## INSTALLATION

**Preliminary**—Remove the packing material from the Radiotrons. Refer to the tube location diagram on rear of receiver, and *make certain*:

- (a) That all tubes are in the proper sockets and pressed down firmly.
- (b) That all shields are rigidly in place over the Radiotrons shown by double circles on the diagram.
- (c) That the short flexible leads shown on the diagram are attached to the top grid contacts of the proper Radiotrons as indicated, and that the spring contact caps are pressed down firmly.

**NOTE**—For the RCA-55 Radiotron *only*, the grid lead must be enclosed by the cylindrical tube shield. A slot is provided at the bottom of this shield for entrance of the lead.

- (d) That the lid is securely in place on the shield of the RCA-58 Radiotron designated by the heavy circle on the diagram.

**Location**—The instrument should be located close to the antenna lead-in and ground connections, and near an electrical outlet.

**External Connections**—Figure 1 shows the external connections and recommended antenna system. It is essential that a good ground connection be provided. Make connections to the antenna and ground as illustrated. Then connect

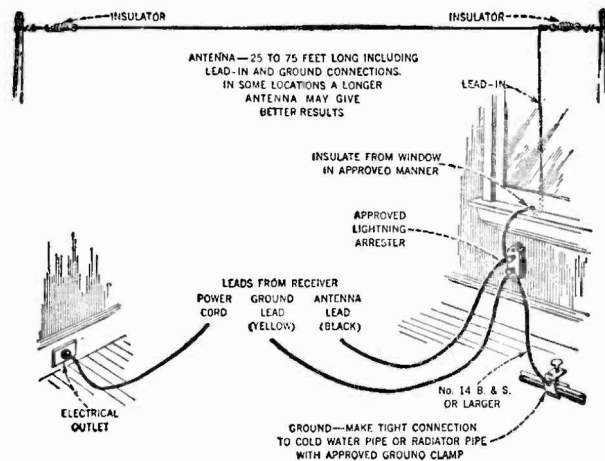

Figure 1

the power cord to an electrical outlet supplying alternating current at the voltage and frequency (cycles) for which the instrument is rated (see rating label on rear of receiver).

## OPERATION

The operating controls are shown in Figure 2. Proceed as follows:

1. Apply power by turning the Tone Control knob clockwise from the "off" position; set this control near the middle of its range. Several seconds are required for the Radiotrons to heat before satisfactory reception is possible.



Figure 2

2. Advance the Volume Control about one quarter turn from the extreme counter-clockwise position and turn the Station Selector in either direction until a station is heard. (The dial scale is calibrated in kilocycles to facilitate selecting stations of known frequency.) If no station is heard, advance the Volume Control further in a clockwise direction and again rotate the Station Selector.

3. After receiving a signal, turn the Volume Control counter-clockwise until the volume is reduced to a low level.

Now readjust the Station Selector accurately to the position mid-way between the points where the quality becomes poor or the signal disappears. *This setting minimizes the proportion of background noise and provides the fine quality of reproduction possible with this instrument.*

4. Adjust the Volume Control to secure the desired volume.

**NOTE**—The *automatic volume control* maintains the volume substantially constant irrespective of normal fluctuations of signal strength (fading). Also, other stations with good signal strength will be received at approximately the same volume without readjustment of the Volume Control.

5. Adjust the Tone Control to obtain the desired tone quality, or turn it counter-clockwise to reduce noise interference.

6. When through operating, switch off the power by turning the Tone Control knob to the extreme counter-clockwise position.

**Radiotrons**—Improved results may sometimes be obtained by interchanging the RCA-58 Radiotrons in their sockets. *The power should be switched off before removing any Radiotron from its socket.* Spare Radiotrons should be kept on hand.

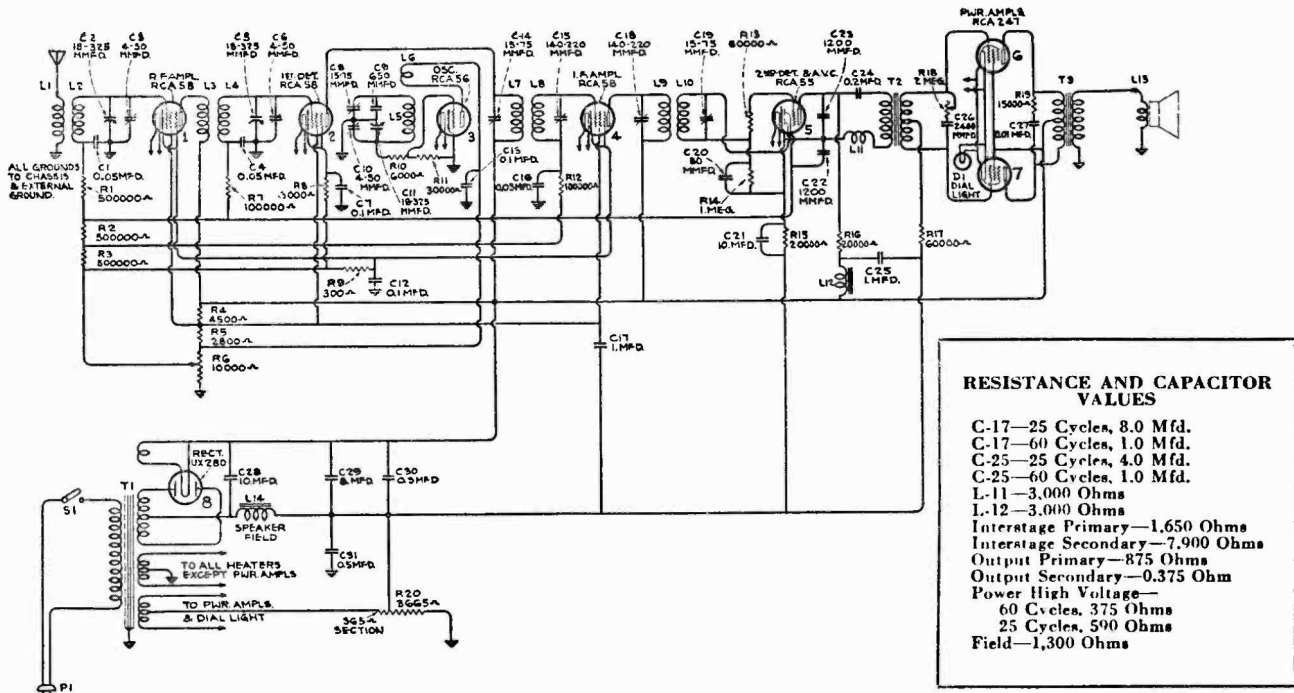

Figure 3—Schematic Circuit

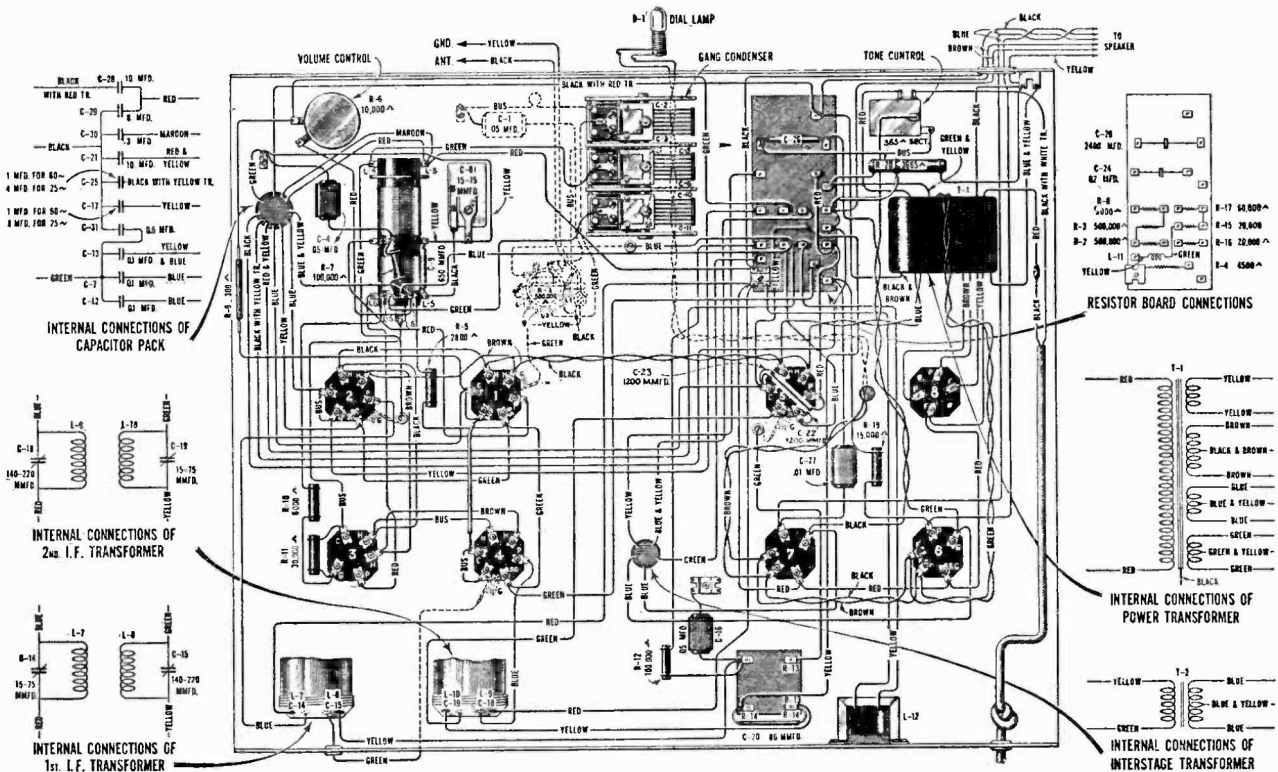

Figure 4—Chassis Wiring Diagram

# SERVICE DATA

## Electrical Specifications

Voltage Rating	105-125 Volts
Power Consumption	100 Watts
Type and Number of Radiotrons	3 RCA-58, 1 RCA-56, 1 RCA-55, 2 RCA-247, 1 UX-280—Total, 8
Type of Circuit	Super-Heterodyne with A. V. C., tone control and push-pull Pentode Output
Undistorted Output	3 Watts
R. F. and Oscillator Alignment Frequency	600 K. C. and 1400 K. C.
Intermediate Frequency	175 K. C.

This receiver is an eight tube Super-Heterodyne incorporating Automatic volume control, tone control and Push-Pull Pentode Output. Service Data will be found to be similar to that of other Super-Heterodyne receivers incorporating similar features.

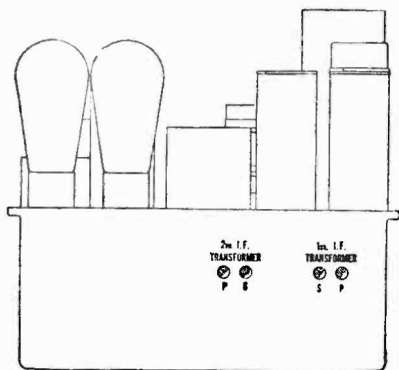

Figure 5—I. F. Alignment Location

## Line-up Adjustments

**I. F. Tuning Adjustments**—Two transformers comprising four tuned circuits are used in the intermediate amplifier. These are tuned to 175 K. C. and the adjustment screws are accessible from the rear of the chassis. See Figure 5 for location of the adjustment screws and proceed as follows:

- Procure a modulated oscillator giving a signal at 175 K. C., a non-metallic screw driver such as Stock No. 7065 and an output meter.
- Remove the oscillator tube and connect a ground to the chassis.
- Connect the oscillator output between the first detector control grid and chassis ground. Connect the output meter across the voice coil of the loudspeaker and adjust the oscillator output so that with the receiver volume control at maximum, a *slight deflection* is obtained in the output meter.
- Adjust the secondary and then the primary of the second and then the first I. F. transformers until a

maximum deflection is obtained. Keep the oscillator output at a low value so that only a slight deflection is obtained on the output meter at all times. Go over these adjustments a second time, as there is a slight interlocking of adjustments. This completes the I. F. Adjustments.

**R. F. and Oscillator Adjustments**—The three gang capacitor screws are accessible through the bottom cover and the 600 K. C. oscillator trimmer through the top of the chassis adjacent to the R. F. coil. Proceed as follows:

- Procure a modulated oscillator giving a signal at 1400 K. C. and 600 K. C., a non-metallic screw driver such as Stock No. 7065 and an output meter.

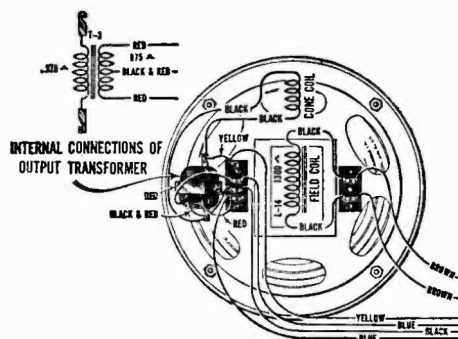

Figure 6—Loudspeaker Wiring

- Connect the output of the oscillator to the antenna and ground lead of the receiver. Check the dial at the extreme maximum position of the tuning capacitor. The indicator should be at the short line on the dial. Then set the dial at 1400 K. C., the oscillator at 1400 K. C. and connect the output meter across the cone coil. Adjust the oscillator output so that a slight deflection is obtained when the receiver volume control is at maximum.
- Adjust the three line-up capacitors accessible at the bottom of the receiver until maximum deflection is obtained in the output meter.
- Shift the oscillator frequency to 600 K. C. and tune the signal. Then adjust the 600 K. C. capacitor, accessible through the top, until maximum deflection is obtained. The main tuning capacitor must be rocked back and forth while making this adjustment.
- Then realign at 1400 K. C. This completes the adjustments.

When making both the I. F. and R. F. adjustments, the important point to remember is that the receiver volume control must be at its maximum position and the minimum input signal necessary from the oscillator must be used.

## RADIOTRON SOCKET VOLTAGES

120 Volts, 60 Cycles, A. C. Line—V. C. at Maximum and no Signal

Radiotron No.	Control Grid to Filament or Cathode Volts	Screen Grid to Filament or Cathode Volts	Plate to Filament or Cathode Volts	Plate Current M. A.	Heater or Filament Volts
1. R. F. RCA-58	4.5	100	165	6.0	2.37
2. 1st Det. RCA-58	11.0	95	155	1.5	2.37
3. Oscillator RCA-56	—	—	70	4.5	2.37
4. I. F. RCA-58	4.5	100	165	6.0	2.37
5. 2nd Det. RCA-55 and A.V.C.	—	—	55	4.7	2.37
6. Power RCA-247	19.0	235	225	20.0	2.37
7. Power RCA-247	19.0	235	225	20.0	2.37

## OTHER IMPORTANT VOLTAGES

2nd Detector and A. V. C. Cathode to Low Side of Field. 105 Volts  
Chassis to Low Side of Field. . . . . 90 Volts

Voltage Across Field. . . . . 120 Volts  
Rectifier. . 370 Volts R.M.S. Each Plate—80 M.A. Each Plate

# REPLACEMENT PARTS

Insist on genuine factory tested parts, which are readily identified and may be purchased from authorized dealers

Stock No.	DESCRIPTION	List Price	Stock No.	DESCRIPTION	List Price
<b>RECEIVER ASSEMBLIES</b>					
2746	Socket—Dial lamp socket . . . . .	\$0.20	6370	Tone control—Complete with mounting nut.	\$1.34
2747	Cap—Contact cap—Package of 5 . . . . .	.50	7054	Cord—Power cord . . . . .	.60
2749	Capacitor—2,400 mmfd. capacitor . . . . .	.35	7062	Capacitor—Adjustable trimming capacitor —Capacity 15 to 70 mmfd. . . . .	.50
3003	Cushion—Sponge rubber chassis support cushions—Package of 4 . . . . .	.30	7065	Screw driver—Micarta screw driver for I. F., R. F. and oscillator condensers . . . . .	.80
3048	Resistor—500,000 ohms—Carbon type— $\frac{1}{2}$ watt—Package of 5 . . . . .	1.00	7439	Drum—Dial drum with 3 dial mounting nuts.	.35
3076	Resistor—1 megohm—Carbon type— $\frac{1}{2}$ watt —Package of 5 . . . . .	1.00	7440	Scale—Dial and dial scale . . . . .	.50
3077	Resistor—30,000 ohms— $\frac{1}{2}$ watt—Carbon type—Package of 5 . . . . .	1.00	7481	Coil—Detector and oscillator coil complete with mounting bracket . . . . .	2.20
3252	Resistor—100,000 ohms— $\frac{1}{2}$ watt—Carbon type—Package of 5 . . . . .	1.00	7484	Socket—UY type Radiotron socket . . . . .	.35
3369	Resistor—4,500 ohms—Porcelain type—20 watts . . . . .	.85	7485	Socket—6 contact Radiotron socket . . . . .	.40
3437	Knob—Noise suppressor knob . . . . .	.60	7510	Shield—Radiotron tube shield—Maroon finish . . . . .	.30
3449	Coil—Choke coil mounted on resistor board.	1.12	7511	Shield—Radiotron tube shield top—Maroon finish . . . . .	.25
3450	Capacitor—0.2 mfd. mounted on resistor board . . . . .	.46	7549	Transformer—Interstage audio transformer . .	2.48
3451	Bracket—Dial lamp bracket and indicator— Package of 2 . . . . .	.38	7550	Capacitor pack—Comprising two 10.0 mfd., one 8.0 mfd., one 0.3 mfd., two 1.0 mfd., one 0.5 mfd., and three 0.1 mfd. capacitors in metal container—For 60 cycle operation.	7.40
3455	Capacitor—0.01 mfd. . . . .	.44	7551	Transformer—Power transformer—105–125 volts—50–60 cycles . . . . .	6.40
3456	Capacitor—0.05 mfd. . . . .	.44	7552	Capacitor—3 gang variable tuning capacitor complete with mounting screws and washers . . . . .	5.20
3457	Resistor—Porcelain type—3,665 ohms— Tapped at 365 ohms . . . . .	.78	7556	Transformer—Power transformer—105–125 volts—25–50 cycles . . . . .	8.50
3458	Resistor—2,800 ohms—Carbon type— $\frac{1}{2}$ watt—Package of 5 . . . . .	1.00	7564	Capacitor pack—Comprising two 10.0 mfd., two 8.0 mfd., one 0.3 mfd., one 4.0 mfd., one 0.5 mfd. and three 0.1 mfd. capacitors in metal container—For 25 cycle operation.	7.24
3459	Capacitor—80 mmfd. capacitor . . . . .	.44	7565	Shield—Radiotron tube shield top—Red . . . .	.25
3460	Capacitor—1,200 mmfd. capacitor . . . . .	.30	7566	Shield—Radiotron tube shield—Red . . . . .	.30
3468	Resistor—300 ohms—Flexible type—Pk. of 5.	1.00	<b>REPRODUCER ASSEMBLIES</b>		
6142	Resistor—6,000 ohms— $\frac{1}{2}$ watt—Carbon type—Package of 5 . . . . .	1.00	3237	Screw assembly—Comprising 4 screws, 8 nuts, 4 washers, and 4 eyelets—Package of 1 set . . . . .	.50
6192	Spring—3 gang tuning capacitor drive cord tension spring—Package of 10 . . . . .	.30	6184	Board—Terminal board complete with 3 terminals—Package of 5 . . . . .	.50
6279	Resistor—15,000 ohms— $\frac{1}{2}$ watt—Carbon type—Package of 5 . . . . .	1.00	6371	Transformer—Output transformer . . . . .	1.90
6282	Resistor—60,000 ohms—Carbon type— $\frac{1}{2}$ watt—Package of 5 . . . . .	1.00	8920	Ring—Cone retaining ring . . . . .	.35
6288	Knob—Station selector, tone control or vol- ume control knob—Package of 5 . . . . .	1.00	8935	Cone—Reproducer cone complete with voice coil—Package of 5 . . . . .	5.25
6298	Cord—3 gang variable tuning capacitor drive cord—Package of 5 . . . . .	.60	9421	Coil assembly—Comprising field coil, magnet and cone support . . . . .	4.32
6300	Socket—4 contact Radiotron socket . . . . .	.35	<b>CABINET ASSEMBLIES</b>		
6301	Reactor—Filter reactor . . . . .	1.40	6113	Foot—Cabinet felt foot—Package of 15 . . . .	.50
6303	Resistor—20,000 ohms— $\frac{1}{2}$ watt—Carbon type—Package of 5 . . . . .	1.00	7523	Escutcheon—Station selector escutcheon . . .	.50
6308	Coil—R. F. coil complete with mounting bracket . . . . .	1.36	X181	Cabinet—Complete less equipment . . . . .	
6323	Shaft—Tuning condenser drive shaft with one flat washer and 2 "C" washers—Pack- age of 2 . . . . .	.20	X182	Baffle board and grille cloth . . . . .	
6367	Transformer—First intermediate frequency transformer . . . . .	2.14			
6368	Transformer—Second intermediate fre- quency transformer . . . . .	2.14			
6369	Volume control—Complete with mounting nut . . . . .	1.16			

.0510



**RCA Victor Company, Inc.**  
Camden, N. J., U. S. A.