

PHILCO RADIO & TELEVISION CORP.

MODELS 41-280, 41-285, 41-287, 41-290(121)

Operations in Order	SIGNAL GENERATOR		RECEIVER			SPECIAL INSTRUCTIONS
	Output Connections to Receiver	Dial Setting	Dial Setting	Control Settings	Adjust Compensators in order	
1	High side to No. 4 terminal loop panel.	455 K. C.	580 K. C.	Vol. Max. Range Switch "S. W." Positions	32A, 32B 34A, 37D	
2	Use loop on generator	1500 K. C.	1500 K. C.	Vol. Max. Range Switch Broadcast	16, 10	Note A
3	Use loop on generator	580 K. C.	580 K. C.	Vol. Max. Range Switch Broadcast	17	Roll Tuning Condensers Note B
4	Use loop on generator	Perform operation No. 2 again				
5	Use loop on generator	6 M. C.	6 M. C.	Range Switch "Police"	16A	
6	Use loop on generator	12 M. C.	12 M. C.	Range Switch "S. W."	17A, 2	Note C

NOTE A — DIAL CALIBRATION: In order to adjust the receiver correctly, the dial must be aligned to track properly with the tuning condenser. To adjust the dial, proceed as follows: With the tuning condenser closed (maximum capacity), set the dial pointer on the extreme left index line at the low frequency end of the broadcast scale. The arrangement of the drive cable in this position is shown in the schematic.

NOTE B — When adjusting the low frequency compensator of Range One (Broadcast) or the aerial padders of the high frequency tuning range; the receiver Tuning Condenser must be adjusted (rolled) as follows: First tune the compensator for maximum output, then vary the tuning condenser of the receiver for maximum output. Now turn the compensator slightly to the right or left and again vary the receiver tuning condenser for maximum output. This procedure of first

setting the compensator and then varying the tuning condenser is continued until maximum output reading is obtained.

NOTE C — To accurately adjust the high frequency oscillator compensator to the fundamental instead of the image signal, turn the oscillator compensator (17A) to the maximum capacity position (clockwise). From this position slowly turn the compensator counter-clockwise until a first peak is obtained on the output meter. Adjust the compensator for maximum output at this first peak.

If the above procedure is correctly performed, the image signal will be found (much weaker) by turning the receiver dial 910 K. C. above the frequency being used on any high frequency range.

The aerial padder (2) must be adjusted to maximum by rolling the tuning condenser. If two signal peaks occur when turning the padder, adjust to maximum output on the second signal peak from the tight position (screw all the way down) of the padder.

MODELS 41-603, 41-604, 41-605, 41-607

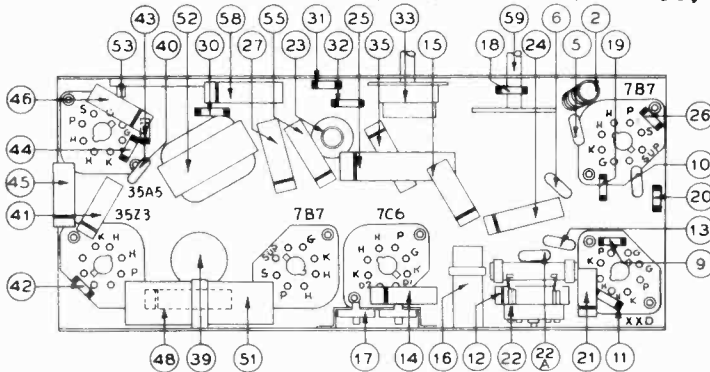

MODEL 41-603
PART LOCATIONS — UNDERSIDE OF CHASSIS

Audio Output Meter: If this type of aligning meter is used, connect it to the voice coil terminals of the speaker or from the plate of the 35A5 tube to the chassis. Adjust the meter for the 0 to 10 volt scale.

Vacuum Tube Voltmeter: To use the vacuum tube voltmeter as an aligning indicator, make the following connections: Attach the negative (—) terminal of the voltmeter to any point in the circuit where the A. V. C. voltage can be obtained. Connect the positive (+) terminal of the vacuum tube voltmeter to the chassis.

Signal Generator: When adjusting the I. F. padders, the high side of the signal generator is connected through a .1 mfd. condenser to the antenna section of the tuning condenser. Connect the ground or low side of the generator to the chassis.

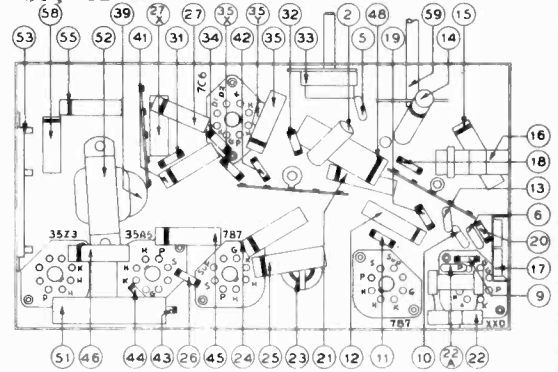

MODELS 41-604, 41-605, 41-607
PART LOCATIONS — UNDERSIDE OF CHASSIS

When aligning the R. F. padders a loop is made from a few turns of wire and connected to the signal generator output terminals; the signal generator is then placed close to the loop of the radio.

The receiver can be adjusted in the cabinet or removed from the cabinet.

When adjusting the radio outside the cabinet the loop aerial should be placed in approximately the same position around or near the chassis as when assembled.

After connecting the aligning instruments adjust the compensators as shown in the tabulation below. Locations of the compensators are shown in the schematic diagram.

If the indicating meter pointer goes off scale when adjusting the compensators, reduce the strength of the signal from the generator.

Operations in Order	SIGNAL GENERATOR		RECEIVER			SPECIAL INSTRUCTIONS
	Output Connections to Receiver	Dial Setting	Dial Setting	Control Settings	Adjust Compensators in order	
1	Ant. Section of tuning	455 K. C.	540 K. C. Tuning Cond. Closed	Vol. Max. Range Switch Brdcast.	39A, 23A, 23B, 22A, 22B	
2	Loop see above instructions	1600 K. C.	1600 K. C.	Vol. Max. Range Switch Brdcast.	17A	Note A
3	Loop see above instructions	1500 K. C.	1500 K. C.	Vol. Max. Range Switch Brdcast.	8	
4	Loop see above instructions	12 M. C.	12 M. C.	Range Switch "S. W."	17, 4	Roll (8) for Max. Note B

NOTE A: — DIAL CALIBRATION: In order to adjust the receiver correctly, the dial must be aligned to track properly with the tuning condenser. To do this, proceed as follows: Turn the tuning condenser to the maximum capacity position (plates fully meshed) With the condenser in this position, set the tuning pointer on the small dot below 550 K. C.

NOTE B: — When adjusting oscillator compensator 17A, tune for maximum on the first signal peak from Tight position (compensator closed). When adjusting the aerial padder 4 of the high frequency tuning range; the receiver Tuning Condenser must be adjusted (rolled) as follows: First tune the compensator for maximum output, then vary the tuning condenser of the receiver for maximum output. Now turn the compensator slightly to the right or left and again vary the receiver tuning condenser for maximum output. This procedure of first setting the compensator and then varying the tuning condenser is continued until maximum output reading is obtained.